

SECTION 1 - RADIO RECEIVERS

1.1 AN/SRR-19 - GENERAL DESCRIPTION.

The AN/SRR-19 and AN/SRR-19A are dual conversion superheterodyne receivers for the frequency range of 30 to 300 KC. They are intended for the reception of low frequency, single side band, multichannel naval fleet radio-teletypewriter broadcasts (USB only), and the reception of A1, A2, and A3 (and F1 with external equipment) broadcasts. An auxiliary LSB amplifier-detector module AM-4528/SRR-19 will replace either the AM amplifier-detector module AM-4529/SRR-19 or AM-4529A/SRR-19, or the USB amplifier-detector module AM-4527/SRR-19 for separate or simultaneous reception of both sidebands. Both receiving sets are similar except for the AM amplifier-detector module supplied with equipment. The AN/SRR-19, up to and including serial number 244, is supplied with AM amplifier-detector AM-4529/SRR-19. The AN/SRR-19A starting with serial number 245 and upward is supplied with AM amplifier-detector AM-4529A/SRR-19. Both AM amplifier-detector units are functionally identical and are physically interchangeable between AN/SRR-19 and AN/SRR-19A radio receiving sets.

1.2 REFERENCE DATA.

- a. Table of Technical Publications - Table 1-1
- b. Primary Power Requirements - Table 1-2
- c. Heat Dissipation - Table 1-3
- d. Unit Weight - Table 1-3.

1.3 INSTALLATION REQUIREMENTS.

- a. Arrangement - The AN/SRR-19 radio receiver may be installed in a standard 19 inch rack or on a radio operating desk (LOP table) or similar flat surface of adequate strength. See Figure 1-1 for rack mounting bracket details. See Figure 1-3 for typical foundation details.
- b. Outline and Mounting Dimensions - Figure 1-2.
- c. Grounding Specifications - All bonding and grounding to be in accordance with Table 1-1 Item No. 4.

1.4 CABLE DIAGRAM AND CONNECTION DETAILS.

- a. Elementary Connections - Figure 1-4.
- b. Electronics Installation and Maintenance Standards - To be in accordance with Table 1-1 Item No. 9.
- c. Security Requirements - To be in accordance with Table 1-1 Item No. 5.

1.5 FIELD CHANGE REQUIREMENTS - None.



ITEM NO.	NAVSHIPS NO. DRAWING NO. MIL. STD. NO.	TITLE
1	0967-163-2010	Vol. I Technical Manual for Radio Receiving Set AN/SRR-19 and AN/SRR-19A(U)
2	0967-163-2020	Vol. II. Technical Manual for Radio Receiving Set AN/SRR-19 and AN/SRR-19A(U)
3	0967-163-2030	Operator's Instruction Chart
4	Mil. Std. 1310A (NAVY)	Shipboard Bonding and Grounding Methods for Electromagnetic Compatibility
5	NAVSHIPSINSTR. 05510.33B	Installation Criteria for Shipboard Secure Electrical Information Processing Systems
6	*RE-F2696139	Outline and Mounting Data
7	*RE-F2696486	Interconnecting Cabling Diagram
8	0981-052-8090	Data Pertaining to Electric Shipboard Cable
9	0967-000-0000	Electronics Installation and Maintenance Books

*These plans are not essential for installation, but if available, use as reference.

TABLE OF TECHNICAL PUBLICATIONS

TABLE 1-1

RADIO RECEIVERS

EQUIPMENT	VOLTAGE	CURRENT	POWER	REMARKS
AN/SRR-19 AN/SRR-19A	105/115/125 VAC, 50-60 or 400 HZ, SINGLE PHASE	1.7 AMP NORMAL	175 WATTS NORMAL	

ORIGINAL

TABLE OF PRIMARY POWER REQUIREMENTS
TABLE 1-2

NAVSHIPS 0967-306-1010

EQUIPMENT	HEAT DISSIPATION	UNIT WEIGHT	REMARKS
AN/SRR-19A AN/SRR-19	150 WATTS (Approx.)	125 LBS.	

TABLE OF MISC. DATA
TABLE 1-3

TABLE 1-2 1-3

1-4

NOTE:
 1. PAINT ALL SURFACES IN ACCORDANCE WITH A1200B, USING A5516B PAINT, LT. GRAY, EXCEPT AS NOTED.

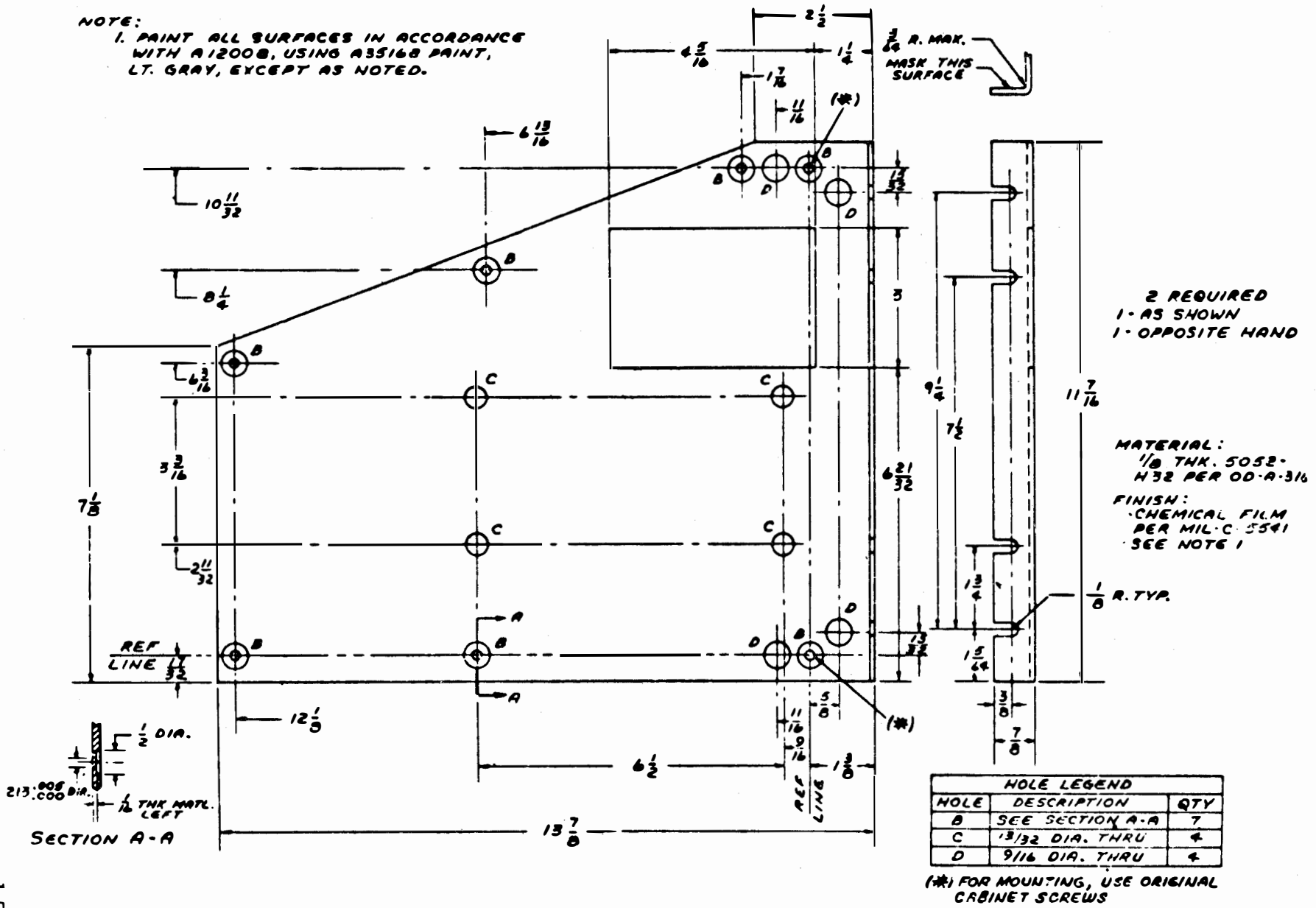

AN/SRR-19 RADIO RECEIVER RACK MOUNTING BRACKET DETAILS

FIGURE 1-1

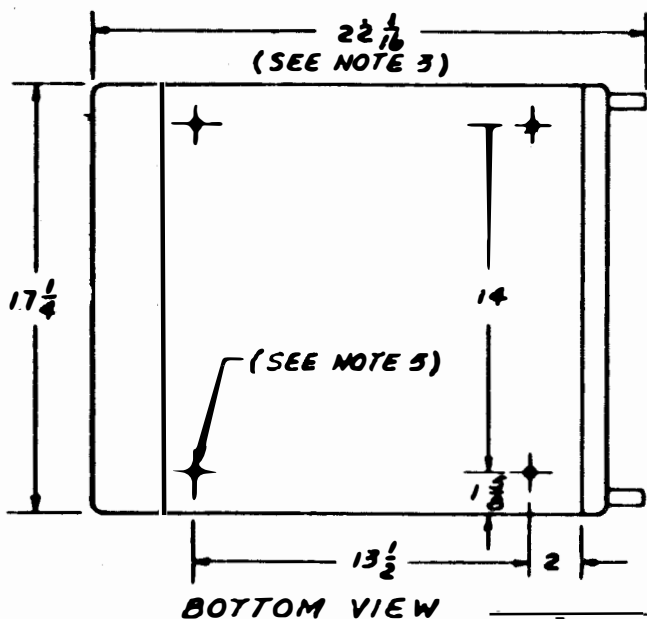

BENCH MOUNTING

1. ALL DIMENSIONS IN INCHES (APPROXIMATE)
2. ALLOW CLEARANCE AROUND EQUIPMENT FOR ADEQUATE VENTILATION.
3. WHEN THE EQUIPMENT IS INSTALLED, CABLE CONNECTIONS AT THE REAR EXTEND THE OVERALL DEPTH TO APPROX. 24 1/2 INCHES.
4. GROUND EQUIPMENT USING 3/8-16 BOLT IN TAPPED HOLE IN REAR OF CABINET.
5. HOLES (4) ARE DRILLED (7/16 DIA.) FOR 3/8 INCH DIA. MOUNTING BOLTS.

BOTTOM VIEW

RACK MOUNTING

1. REMOVE TWO CABINET SCREWS FROM EACH SIDE TO ACCOMMODATE BRACKET HOLES MARKED (*) IN FIGURE 2-3.
2. SECURE EACH BRACKET USING REMOVED CABINET SCREWS AT HOLES (*) AND TEN 8-32 x 3/8 SCREWS WITH #8 LOCK WASHERS.
3. INSTALL CABINET IN RELAY RACK

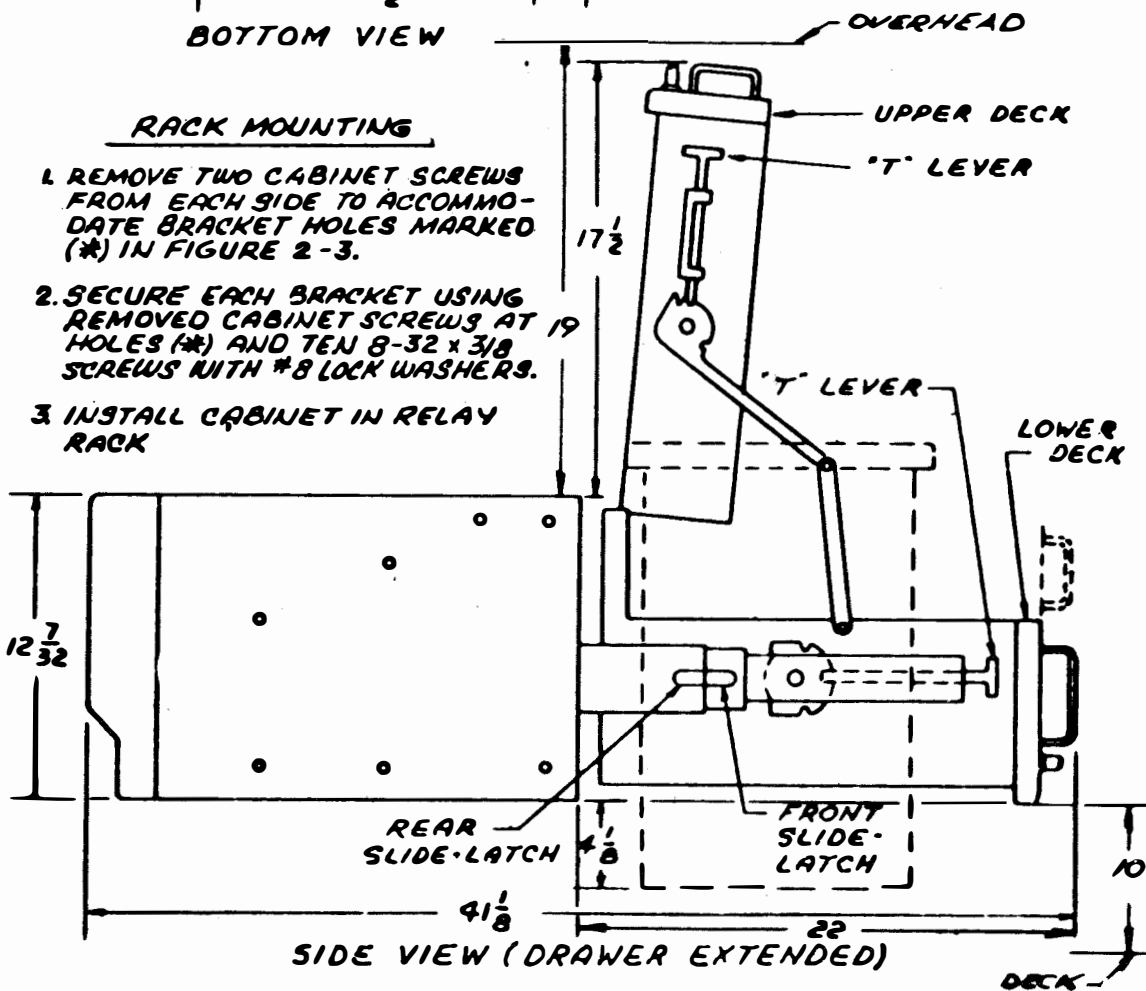

SIDE VIEW (DRAWER EXTENDED)

AN/SRR-19 RADIO RECEIVER

OUTLINE AND MOUNTING DIMENSIONS

FIGURE 1-2

SECTION 1 - RADIO RECEIVERS

1.6 R-390/URR - GENERAL DESCRIPTION

This receiver is a high performance exceptionally stable equipment for general purpose use in fixed or mobile installation for continuous wave (CW), modulated continuous wave (MCW) and amplitude modulation (AM). It can be applied to a space diversity receiving system, either of two types of space diversity radio teletype receiving system. Frequency range is 0.5 to 32.0 megacycles (MC) in 32 steps (including single-sideband (SSB) signals over a continuous frequency range of 0.5 to 32 megacycles (MC)). The receiver is a superheterodyne type with multiple frequency conversion. Double conversion is used when the receiver operates from 8 to 32 megacycles and triple conversion from 0.5 to 8 megacycles.

1.7 REFERENCE DATA.

- a. Table of Technical Publications - Table 1-4.
- b. Primary Power Requirements - Table 1-5.
- c. Heat Dissipation - Table 1-6.
- d. Unit Weight - Table 1-6.

1.8 INSTALLATION REQUIREMENTS

- a. Arrangement - R-390/URR may be installed in any standard 19 inch rack or CY-979/URR cabinet which may be mounted on a radio operating desk (LOP table) or flat foundation. See Figure 1-5 and 1-6 for typical foundation details.
- b. Outline and Mounting Dimensions - Figure 1-7.
- c. Grounding Specifications - All bonding and grounding to be in accordance with Table 1-4 Item No. 2.

1.9 CABLE DIAGRAM AND CONNECTION DETAILS.

- a. Elementary Connections - Figure 1-8
- b. Electronics Installation and Maintenance Standards - To be in accordance with Table 1-4 Item No. 10.
- c. Security Requirements - To be in accordance with Table 1-4 Item No. 11.

1.10 FIELD CHANGE REQUIREMENTS. Table 1-7.



ITEM NO.	NAVSHIPS NO. DRAWING NO. MIL. STD. NO.	TITLE
1	0967-063-2010 0967-063-2020 0967-063-2030	Technical Manual for Radio Receiver R-390/URR (Three Volumes)
2	Mil. Std. 1310A (NAVY)	Shipboard Bonding and Grounding Methods for Electromagnetic Compatibility
3	*RE-F2686342	Interconnecting Wiring Diagram
4	*RE-F2686233	Interconnecting Wiring Diagram
5	*RE-C2687910	Interconnecting Wiring Diagram
6	*RE-F2692586	Standard Plan Interconnecting Wiring Diagram
7	*RE-F2685958	Outline and Mounting Data
8	*RE-D-2686304	Outline and Mounting Data
9	RE-H-2692919	Primary Power Distribution Diagram
10	0967-000-0000	Electronics Installation and Maintenance Books
11	NAVSHIPSINST. 05510.33B	Installation Criteria for Shipboard Secure Electrical Information Processing Systems

*These plans are not essential for installation, but if available, use as reference.

TABLE OF TECHNICAL PUBLICATIONS

TABLE 1-4 (Continued)

RADIO RECEIVERS

NAVSHIPS 0967- 306-1010

TABLE 1-4

ITEM NO.	NAVSHIPS NO. DRAWING NO. MIL. STD. NO.	TITLE
12	0981-052-8090	Data Pertaining to Electric Shipboard Cable

ORIGINAL

1-12

TABLE OF TECHNICAL PUBLICATIONS
TABLE 1-4

EQUIPMENT	VOLTAGE	CURRENT	POWER	REMARKS
R-390/URR	115/230 VAC, 48.62 HZ SINGLE PHASE		250 WATTS	

TABLE OF PRIMARY POWER REQUIREMENTS

TABLE 1-5

EQUIPMENT	HEAT DISSIPATION	UNIT WEIGHT	REMARKS
R-390/URR		75 LBS.	
GY-979/URR CABINET		20 LBS.	

TABLE OF MISC. DATA

TABLE 1-6

RADIO RECEIVERS

NAVSHIPS 0967-306-1010

TABLE 1-7

FIELD CHANGE NUMBER AND SERIAL NO. EFFECTIVITY	NAVSHIPS BULLETIN #	BRIEF DESCRIPTION OF CHANGE	INSTALLING ACTIVITY & MAN HOURS	KIT FSN	IDENTITY
1-R390/URR-AND All R-390A/URR	0967-063-2060	Elim spurious radiation	FA- $\frac{1}{2}$	None	Soldered jumper lead connected between pins 2 and 7 of XV603.
2-R390 /URR As authorized	0285-075-1700	Special bandwidth requirements	FA-8	None	FC accomplishment is recorded on FC plate adjacent to receiver nameplate.
3-R390A/URR All	0967-063-2080	Changes electrical access from terminal strips to MS connectors	FA-2	2N5820-078-5074	Aluminum channel covers term TB102 - TB103 on back of receiver 3 MS type connectors used.
4-R390A/URR All	0967-063-2140	Install diode load test jack	FA-1	None	Presence of green test jack located on the front panel to the right of the phone jack. FC 4 required if FC 3 acc.
5-R390A/URR All	0967-063-2140	Modification to ant. connections	FA-1	None	Presence of shorting plug connected to J104 on rear panel of receiver
6-R390A/URR All	0967-063-	Internal heat reduction	FA-2	2N5820-937 0141	Two-rectifier tubes 26Z5W removed new type heat dissipation tube shields installed on all tubes.
2-R-390A/URR All	0967-063-2070	Increase audio output level on line output terminals	FA- $\frac{1}{2}$	None	Presence of two soldered jumper leads on terminal board TB-101

FIELD CHANGE REQUIREMENTS

TABLE 1-7

(Continued)

ORIGINAL

1-14

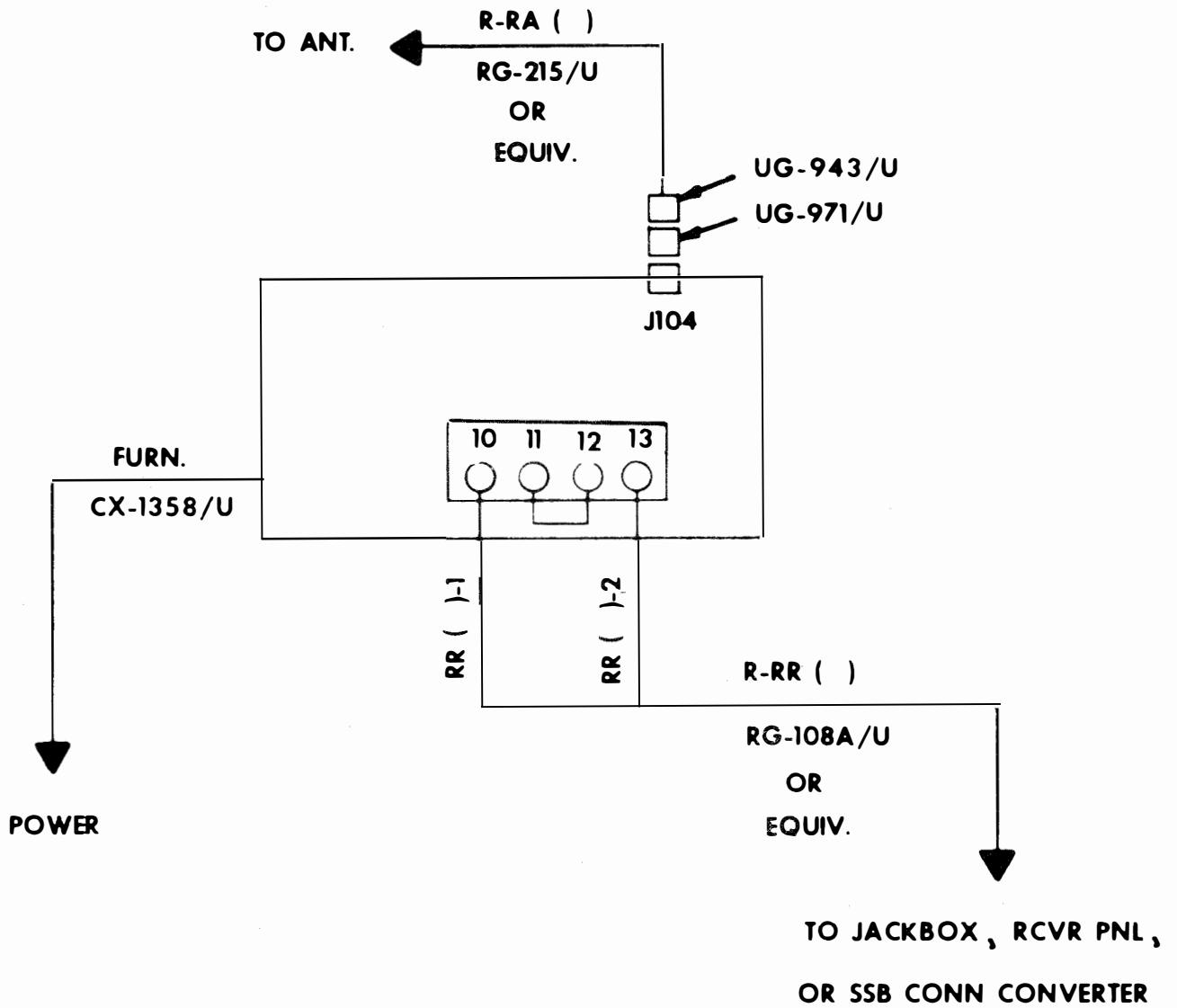

R-390/URR RADIO RECEIVER CABLE DIAGRAM
FIGURE 1-8



SECTION 1 - RADIO RECEIVERS

1.11 R-1051/URR - GENERAL DESCRIPTION

The receiver is a digitally tuned superheterodyne receiver capable of receiving lower sideband (LSB) upper sideband (USB), independent sideband (ISB), frequency shift keyed (FSK), amplitude modulated (AM), and continuous wave (CW) transmissions in the 2.0 to 30.0 megacycle frequency range. The ISB mode of operation allows two different types of intelligency to be received simultaneously, one on the LSB channel and one on the USB channel. FSK reception is obtained by using suitable ancillary equipment such as teletype converter-comparator. The R-1051/URR may also receive tone-modulated continuous wave (MCW), compatible amplitude modulated (compatible AM), and facsimile transmissions. The receiver may be operated in conjunction with a transmitter as a transmitter-receiver in systems such as radio set AN/WRC-1. In this application either simplex or duplex operation is possible. The R-1051/URR may also be used as a separate self-contained receiver.

1.12 REFERENCE DATA

- a. Table of Technical Publications - Table 1-8
- b. Primary Power Requirements - Table 1-9
- c. Heat Dissipation - Table 1-10
- d. Unit Weight - Table 1-10.

1.13 INSTALLATION REQUIREMENTS

- a. Arrangement - The R-1051/URR radio receiver may be installed in a standard 19 inch rack or on a radio operating desk (LOP table) or similar flat surface of adequate strength. See Figure 1-9 for rack mounting details. for typical foundation details.
- b. Outline and Mounting Dimensions - Figure 1-11
- c. Grounding Specifications - All bonding and grounding to be in accordance with Table 1-8 Item No. 4.

1.14 CABLE DIAGRAM AND CONNECTION DETAILS

- a. Elementary Connections - Figure 1-12
- b. Electronics Installation and Maintenance Standards - To be in accordance with Table - 1-8 Item No. 7
- c. Security Requirements - To be in accordance with Table 1-8 Item No. 8.

1.15 FIELD CHANGE REQUIREMENTS - See Table 1-8 Item No. 7.



ITEM NO.	NAVSHIPS NO. DRAWING NO. MIL. STD. NO.	TITLE
1	0967-970-9010 0967-970-9020	Technical Manual for Radio Receiver R-1051/URR
2	0967-970-9040	Maintenance Standards Book for Radio Receiver R-1051/URR
3	0967-970-9030	Performance Standards Sheet for Radio Receiver R-1051/URR
4	Mil. Std. 1310A (NAVY)	Shipboard Bonding and Grounding Methods for Electromagnetic Compatibility
5	*RE-C2686398	Pictorial System Diagram
6	*RE-D2686359	Outline and Mounting Data
7	0967-000-0000	Electronics Installation and Maintenance Books
8	NAVSHIPSINST. 05510.33B	Installation Criteria for Shipboard Secure Electrical Information Processing Systems
9	0981-052-8090	Data Pertaining to Electrical Shipboard Cable

*These plans are not essential for installation, but if available, use as reference.

TABLE OF TECHNICAL PUBLICATIONS

TABLE 1-8

RADIO RECEIVERS

EQUIPMENT	VOLTAGE	CURRENT	POWER	REMARKS
R-1051/URR	115 VAC, 48-450 HZ, SINGLE PHASE		55 WATTS	

ORIGINAL

TABLE OF PRIMARY POWER REQUIREMENTS

TABLE 1-9

NAVSHIPS 0967-306-1010

EQUIPMENT	HEAT DISSIPATION	UNIT WEIGHT	REMARKS
R-1051/URR	55 WATTS	70 LBS.	
MT-3114/UR SHOCK MOUNT		16 LBS.	

TABLE OF MISC. DATA

TABLE 1-10

TABLE 1-9/1-10