

★
NAVSHIPS 92121(A)

INSTRUCTION BOOK

for

RADIO TRANSMITTING SETS

AN/SRT-14, AN/SRT-14A, AN/SRT-15,
AN/SRT-15A, AN/SRT-16 AND AN/SRT-16A

SECTION 3
INSTALLATION

FEDERAL TELEPHONE AND RADIO COMPANY

A division of INTERNATIONAL TELEPHONE AND TELEGRAPH CORPORATION

CLIFTON, NEW JERSEY

DEPARTMENT OF THE NAVY
BUREAU OF SHIPS

★
Contract: NObsr-52021
NObsr-52622

Approved by BuShips: 26 October 1955

TABLE OF SECTIONS

<i>Section</i>	<i>Title</i>
1	General Description
2	Theory of Operation
3	Installation
4	Operation
5	Operator's Maintenance
6	Preventive Maintenance
7	Corrective Maintenance
8	Parts Lists

TABLE OF CONTENTS

<i>Paragraph</i>	<i>Page</i>	<i>Paragraph</i>	<i>Page</i>
1. Introduction	3-1	(2) Mounting	3-24
2. Unpacking Procedures	3-1	(3) Radio Modulator-Power Supply	3-24
3. Location of Equipment	3-5	(4) Transmitter Coupler	3-25
<i>a.</i> Transmitter Bay	3-5	<i>c.</i> Antenna Tuning Equipment	3-25
(1) Clearance Requirements	3-5	<i>d.</i> Remote Radiophone Unit	3-25
(2) Variation in Transmitter Bay Ar- rangement	3-5	6. Main Test Cable Assembly	3-25
<i>b.</i> Antenna Tuning Equipment	3-7	<i>a.</i> Preparation of Cable	3-26
(1) Antenna Coupler CU-372/SRT	3-7	<i>b.</i> Preparation of Connector Assemblies	3-27
(2) Radio Frequency Tuner TN-229/ SRT	3-7	<i>c.</i> Wiring and Final Assembly	3-27
<i>c.</i> Remote Radiophone Unit	3-8	7. Initial Adjustments	3-28
4. Assembly Procedure	3-8	<i>a.</i> General	3-28
<i>a.</i> Transmitter Bay	3-8	<i>b.</i> Power Input Adjustments	3-28
(1) AN/SRT-14 Arrangement "C"	3-8	<i>c.</i> Checking Individual Components	3-30
(2) AN/SRT-15 Arrangement "A ₁ "	3-13	<i>d.</i> Trial Operation	3-30
(3) AN/SRT-16 Arrangement "D"	3-17	(1) Transmitter Bay	3-30
(4) Transmitter Coupler CU-402/SRT	3-23	<i>a.</i> 100-Watt Operation	3-30
<i>b.</i> Antenna Tuning Equipment	3-23	<i>b.</i> 500-Watt Operation	3-34
5. Wiring The Equipment	3-23	<i>c.</i> Transmitter Coupler CU- 402/SRT	3-34
<i>a.</i> General	3-23	<i>d.</i> Remote Control	3-34
<i>b.</i> Transmitter Bay	3-24	(2) Antenna Tuning Equipment	3-36
(1) Transmitter Group Cabinets	3-24	<i>a.</i> Pressurization	3-36
		<i>b.</i> Trial Operation	3-40

LIST OF ILLUSTRATIONS

<i>Figure</i>	<i>Title</i>	<i>Page</i>	<i>Figure</i>	<i>Title</i>	<i>Page</i>
3-1	Simplified Pictorial View, Radio Transmit- ting Set AN/SRT-14	3-3	3-13	Installing E-702 Cables	3-32
3-2	Simplified Pictorial View, Radio Transmit- ting Set AN/SRT-15	3-6	3-14	Assembly of UG-167A/U Connector on RG-18/U Coaxial Cable	3-35
3-3	Simplified Pictorial View, Radio Transmit- ting Set AN/SRT-16	3-9, 3-10	3-15	Assembly of UG-154/U Connector on RG-18/U Coaxial Cable	3-36
3-4	Transmitter Group OA-684/SRT, Unpack- ing Procedure	3-11	3-16	Assembly of Adapter (CBTL No. A20112- 54) on RG-17/U First Extrusion Cable	3-37
3-5	Transmitter Coupler CU-402/SRT, Con- trol-Indicator C-1352/SRT and Electron Tube 4-400A, Unpacking Procedure	3-12	3-17	Input Power Link Arrangements, Radio Modulator-Power Supply (Booster)	3-38
3-6	Mounting MT-1423/SRT, Unpacking Pro- cedure	3-14	3-18	Installation of Electron Tubes V-1601 and V-1602	3-39
3-7	Antenna Coupler CU-372/SRT, Unpack- ing Procedure	3-17	3-19	Typical Pressurization of Antenna Tuning Equipment	3-39
3-8	Radio Frequency Tuner TN-229/SRT, Un- packing Procedure	3-19	3-20	Pictorial System Diagram, AN/SRT-14	3-41
3-9	Radio Modulator-Power Supply OA-685/ SRT, Unpacking Procedure	3-20	3-21	Pictorial System Diagram, AN/SRT-15	3-43
3-10	Installation Material AN/SRT-15	3-23	3-22	Pictorial System Diagram, AN/SRT-16	3-45
3-11	Typical Transmitter Bay Arrangements	3-29	3-23	Outline Drawing, Transmitter Bay, AN/ SRT-14	3-47
3-12	Assembly of UG-21B/U or UG-23B/U Connector on RG-8/U Coaxial Cable	3-31	3-24	Outline Drawing, Transmitter Bay, AN/ SRT-15	3-49
			3-25	Outline Drawing, Transmitter Bay, AN/ SRT-16	3-51
			3-26	Terminal Board and Cable Entrance Data, AN/SRT-14, 15 and 16	3-53

LIST OF ILLUSTRATIONS (Cont'd)

<i>Figure</i>	<i>Title</i>	<i>Page</i>	<i>Figure</i>	<i>Title</i>	<i>Page</i>
3-27	Outline Drawing, Transmitter Coupler CU-402/SRT	3-55	3-33	Cable Assembly Instructions for Multicon- ductor Connectors	3-67
3-28	Outline Drawing, Antenna Coupler CU- 372/SRT	3-57	3-34	Primary Power Distribution Diagram, Transmitter Group and Mounting, AN/ SRT-14, 15 and 16	3-69
3-29	Outline Drawing, Radio Frequency Tuner TN-229/SRT	3-59	3-35	Primary Power Distribution Diagram, Ra- dio Modulator-Power Supply (Booster), AN/SRT-15 and 16	3-71
3-30	Interconnecting Cabling Diagram, AN/ SRT-14	3-61	3-36	Primary Power Distribution Diagram, An- tenna Coupler and R-f Tuner, AN/SRT- 14, 15 and 16	3-73
3-31	Interconnecting Cabling Diagram, AN/ SRT-15	3-63			
3-32	Interconnecting Cabling Diagram, AN/ SRT-16	3-65			

LIST OF TABLES

<i>Table No.</i>	<i>Title</i>	<i>Page</i>
3-1	Units Comprising AN/SRT-14, 15 and 16	3-1
3-2	Shipping Data	3-2
3-3	Installation Material	3-4
3-4	Antenna Tuning Equipment Critical Cable Lengths	3-7
3-5	Antenna Tuning Equipment Connector As- semblies	3-26
3-6	Main Test Cable Assembly Drawings	3-27
3-7	Main Test Cable Assembly Cross-Refer- ence List	3-28
3-8	Typical Meter Readings at 6 Mc, Hand, Key Down	3-33
3-9	Critical Radio Frequency Oscillator Ad- justments	3-33

SECTION 3 INSTALLATION

1. INTRODUCTION.

This section contains a discussion of the method of installing and making preliminary tests for Radio Transmitting Sets AN/SRT-14, AN/SRT-15 and AN/SRT-16. The major components included are listed in table 3-1. The Navy-supplied radiophone unit is considered as a separate entity for the purposes of this discussion. The components composing each equipment are illustrated in the simplified pictorial views, figures 3-1, 3-2, and 3-3. Each equipment is shown on an interconnected system basis in figures 3-20, 3-21, and 3-22.

Note

The AN/SRT-14A, 15A and 16A are non-magnetic versions of the AN/SRT-14, 15 and 16 respectively. As the nonmagnetic versions vary from the standard types only in the material used for cabinet panels, all information on the installation of the AN/SRT-14, 15 and 16, as set forth in the following section, applies equally as well for the AN/SRT-14A, 15A and 16A.

Note

Where, throughout this section, reference is made to either low level radio modulator or high level radio modulator, it should not be interpreted as meaning the technique of modulation known as grid modulation or low level modulation, but rather as referring to the operating *power* level.

In this section, the term *stack* is used to describe all the components of the transmitter bay that are supported by a single mounting. Thus the AN/SRT-14 transmitter

bay is composed of a single stack and a transmitter coupler, which is a component of the Transmitter Group OA-684. The standard AN/SRT-15 transmitter bay comprises a "transmitter stack", a "booster stack", and one transmitter coupler. The AN/SRT-16 comprises two similar stacks, usually identified as "100 watt stack" and "500 watt stack," plus two transmitter couplers.

The assembly procedure has been divided into paragraphs according to the type of work required rather than the unit being installed. Thus instructions for the mechanical assembly of all units are found in paragraph 4, wiring in 5. Within these paragraphs, the material has been arranged by units to permit installation personnel to complete the installation of each unit separately if desirable.

In paragraph 4, Mechanical Assembly, one complete set of instructions is given for the transmitter bay of each set. Wherever two or more arrangements of the transmitter bay are possible, the recommended method is described. Other methods of assembly are considered as variations of the recommended method.

After the equipment is assembled and wired, the main test cable should be assembled and wired in accordance with the instructions given in paragraph 6.

Paragraph 7 sets forth the checks and initial adjustments together with the operation procedures for the first trial operation of the equipment.

2. UNPACKING PROCEDURES.

The complete Radio Transmitting Set AN/SRT-14 is shipped in 11 boxes, an AN/SRT-15 in 17 boxes, and AN/SRT-16 in 24 boxes. The components constituting each set and the number of boxes required for each set are shown in table 3-2.

TABLE 3-1. UNITS COMPRISING AN/SRT-14, 15 AND 16

UNIT	AN/SRT-14	AN/SRT-15	AN/SRT-16
TRANSMITTER BAY:	1	1	1
Mounting MT-1423/SRT	1	2	2
Transmitter Group OA-684/SRT	1	1	2
Radio Modulator — Power Supply OA-685/SRT	—	1	1
Cover (Booster) CW-341/SRT	—	1	—
ANTENNA TUNING EQUIPMENT:			
Antenna Coupler CU-372/SRT	1	1	2
Radio Frequency Tuner TN-229/SRT	1	1	2
REMOTE UNITS:			
Remote Radiophone Unit (Not supplied with equipment. Quantity may vary with individual installation.)			

TABLE 3-2. SHIPPING DATA

BOX	ENCLOSURES	NUMBER OF BOXES SUPPLIED			REFER TO FIG. NO.
		AN/SRT-14	AN/SRT-15	AN/SRT-16	
A	Transmitter Group OA-684/SRT (less Transmitter Coupler CU-402/SRT, Control-Indicator C-1352/SRT and Electron Tube 4-400A)	1	1	2	3-4
B	Transmitter Coupler CU-402/SRT, Control-Indicator C-1352/SRT, and Electron Tube 4-400A)	1	1	2	3-5
C	Mounting MT-1423/SRT	1	2	2	3-6
D	Antenna Coupler CU-372/SRT	1	1	2	3-7
E	Radio Frequency Tuner TN-229/SRT	1	1	2	3-8
F	Radio Modulator-Power Supply OA-685/SRT (less two Electron Tubes 4-125A)	—	1	2	3-9
G	Electron Tube 4-125A (2)	—	1	1	—
H	Installation Material for AN/SRT-14 MK-230/SRT-14 (lot 1), Instruction Books (2)	1	—	—	—
I	Installation Material for AN/SRT-14	1	—	—	—
J	Installation Material for AN-SRT/15 MK-232/SRT-15 (lot 1), incl Cover CW-341/SRT	—	1	—	—
K	Installation Material for AN-SRT/15 MK-232/SRT-15 (lot 2), Instruction Books (2)	—	1	—	—
L	Installation Material for AN/SRT-16 MK-234/SRT-16 (lot 1)	—	—	1	—
M	Installation Material for AN/SRT-16 MK-234/SRT-16 (lot 2), Instruction Books (2)	—	—	1	—
N	Equipment Spares for Transmitter Group OA-684/SRT	1	1	2	—
O	Equipment Spares for Mounting MT-1423/SRT	1	2	2	—
P	Equipment Spares for Antenna Coupler CU-372/SRT	1	1	2	—
Q	Equipment Spares for Radio Frequency Tuner TN-229/SRT	1	1	2	—
R	Equipment Spares for Radio Modulator-Power Supply OA-685/SRT (less spare transformer T-1502)	—	1	1	—
S	Equipment Spare Transformer (T-1502)	—	1	1	—
Total number of boxes per set		11	17	24	

Boxes N through S are cartons containing the various sets of equipment spares and need not be opened for purposes of installing the equipment. Boxes A, C through F have outer wooden cases and disassembly is outlined in figures 3-4, 3-6 through 3-9 respectively. Box B is a consolidating carton for the three components packed therein, which are packed in individual cartons as shown in figure 3-5. Box G is a small carton for packaging the two 4-125A electron tubes that are used

in the Radio Modulator MD-230/SRT of AN/SRT-15 or 16.

The installation material for each AN/SRT-14, 15 or 16 (MK-230/SRT-14, MK-232/SRT-15 or MK-234/SRT-16 respectively) is packed in two cartons together with two copies of the instruction book. Table 3-3 shows the breakdown of the installation material in accordance with the box in which they are packed. A display of the installation material for an AN/SRT-15 is shown in figure 3-10.

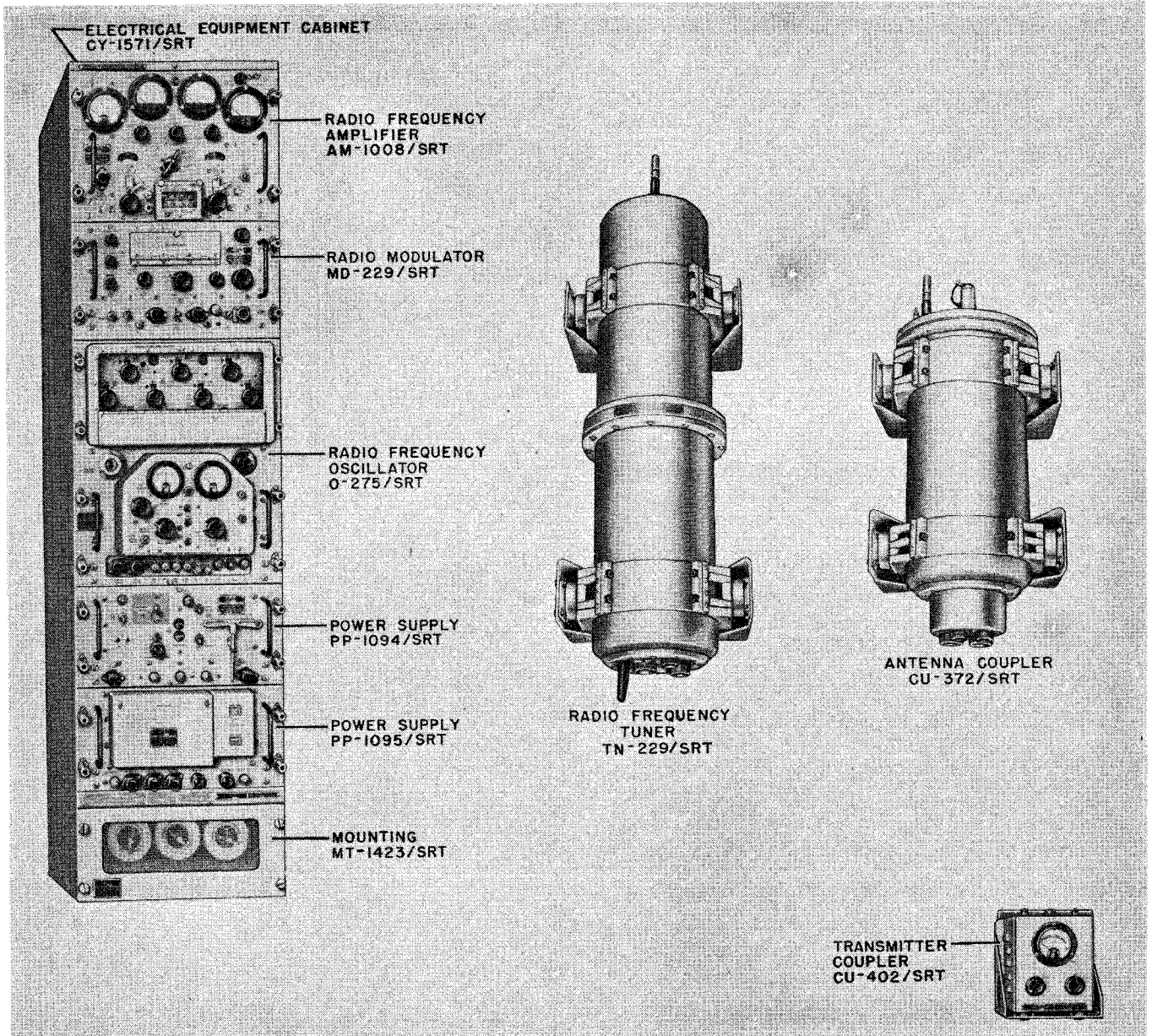

Figure 3-1. Simplified Pictorial View, Radio Transmitting Set AN/SRT-14

TABLE 3-3. INSTALLATION MATERIAL

ITEM	QUANTITY SUPPLIED				
	AN/SRT-14	AN/SRT-15		AN/SRT-16	
	Box H	Box J	Box K	Box L	Box M
Shock Mount, Barry No. C-4300-T10	4	4	—	8	—
Shock Mount, Barry No. C-4125-T10	—	4	—	—	—
5/8-11 x 1 in. lg screw, cap, hex hd, stl st, type 304	4	8	—	—	8
5/8 nom x 0.203 in. w x 0.156 in. thk (med) washer, spring lock, stl st, type 302	4	—	8	8	—
1/2-13 x 1 in. lg screw, cap, hex hd, stl st, type 304	8	24	—	—	36
1/2 nom x 0.171 in. w x 0.125 in. thk (med) washer, spring lock, stl st, type 302	8	—	24	36	—
5/16-18 NC-2 x 1-1/4, in. lg screw, cap, hex hd, stl st, type 304	—	—	6	14	—
5/16 nom x 0.125 in. w x 0.078 in. thk (med) washer, spring lock, stl st, type 302	—	—	6	14	—
5/16-18 NC-2 nut, hex, stl st, type 303	—	—	6	14	—
10-32 nut, hex, stl st, type 303	—	—	6	—	—
No. 10 (0.019 nom) x 0.062 in. w x 0.047 in. (med) washer, spring lock, stl st, type 302	—	—	6	—	—
Eyebolt; 1/2-13 thd.	4	4	—	—	8
Leveling Insert; Federal Telecommunication Lab. No. NL-982598-1	10	—	14	24	—
Plug Button; United-Carr No. 51117	12	—	18	28	—
Model Nameplate	1	—	1	1	—
Transmitter Bay Interstack Cables, AN/SRT-14	1 set	—	—	—	—
Transmitter Bay Interstack Cables, AN/SRT-15	—	—	1 set	—	—
Transmitter Bay Interstack Cables, AN/SRT-16	—	—	—	—	1 set
Cable Assembly; Federal Telecommunication Lab. No. NL-901214-2	1	1	—	2	—
Connector, Plug; Bendix Scintilla No. 10-64632-8S	2	—	2	4	—
Connector, Plug; Bendix Scintilla No. 10-64632-8P	1	—	1	2	—
Connector, Plug; Bendix Scintilla No. 10-64624-28S	2	—	2	4	—
Connector, Plug; Bendix Scintilla No. 10-64624-28P	1	—	1	2	—
Cable Accessory; Bendix Scintilla No. 10-35952-321	3	—	3	6	—
Cable Accessory; Bendix Scintilla No. 10-35952-244	3	—	3	6	—
Cap Assembly; Bendix Scintilla No. 10-35963-32	3	—	3	6	—
Cap Assembly; Bendix Scintilla No. 10-35963-24	3	—	3	6	—
Connector, Plug; type UG-154/U	3	—	3	6	—
Connector, Plug; type UG-167A/U	1	—	1	2	—
Connector, Plug; type UG-21B/U	1	—	1	2	—
Connector, Plug; type UG-23B/U	1	—	1	2	—

TABLE 3-3. INSTALLATION MATERIAL (Cont'd)

ITEM	QUANTITY SUPPLIED				
	AN/SRT-14	AN/SRT-15		AN/SRT-16	
	Box H	Box J	Box K	Box L	Box M
Sleeving, 1/2 in. lg, Bentley-Harris No. BH "649" No. 13	140	—	140	280	—
Insulation Tape, Electrical; polyethylene, 1 in. wd, 30 ft lg roll	2	—	2	4	—
Ground Strap; 0.032 in. thk, 1/2 in. wd, 24 lg.	2	—	2	4	—
Main Test Cable Assembly*	1	—	1	—	1
Instruction Books	2 sets	—	2 sets	—	2 sets
Cover CW-341/SRT	—	1	—	—	—
Sway Mount; Federal Telecommunication Lab No. NL-901559-12	2	2	—	4	—
3/8-16 NC-2 x 1 in. lg screw, cap, hex hd, stl st, type 304	8	8	—	—	16
3/8 nom x 0.141 in. w x 0.094 in. thk (med) washer, spring lock, stl st, type 302	8	8	—	—	16
Leveling Insert; Federal Telecommunication Lab. No. NL-901561-1	2	—	4	4	—
Plug Button; United-Carr No. 48199	12	—	18	28	—

*Not required to install equipment.

3. LOCATION OF EQUIPMENT.

a. TRANSMITTER BAY.

(1) CLEARANCE REQUIREMENTS.—For convenience in operation and maintenance, it is desirable to locate the transmitter bay in the main radio room if enough space is available. The ambient temperature at the installation site should be within a -20°C. (-4°F.) to +50°C. (+122°F.) range. The location chosen for the transmitter bay must provide top and side clearance for a 1/2-inch extrusion of the transmitter group on its shock mounts and adequate rear clearance for cable entry and ventilation. Additional room must be provided to permit removal and replacement of the individual drawers and to allow working space for maintenance personnel repairing the equipment. A minimum of 36 inches clearance in the front of the stack is required to permit the rear of a transmitter bay drawer and slide to clear the front of the cabinets. Since these drawers weigh from 75 to over 100 pounds each, additional clearance sufficient to provide working space for two men must be provided. If the area is too confined to permit one man to stand on each side of the open drawer, additional front clearance must be added to allow one man to work from the front of the open drawer while his partner works at one side. For specific recommendations, consult the outline drawing of the transmitter bay to be installed (figures 3-23, 3-24, 3-25).

(2) VARIATION IN TRANSMITTER BAY ARRANGEMENT.—The design of the AN/SRT-15 and AN/SRT-16 radio transmitting sets allows selection of any one of several transmitter bay arrangements. This

variety of arrangements permits installation personnel to take into consideration any obstruction or space restriction in the radio room and to select the transmitter bay arrangement that is most adaptable to their particular installation. The primary considerations in selecting any of these arrangements are the amount of space provided at the installation site and the amount of cabling necessary for the arrangement chosen. Illustrations of the various methods of assembly for the AN/SRT-14, 15 and 16 series appear in figure 3-11.

The AN/SRT-14 transmitter bay, consisting of a transmitter group and a single mounting, may be assembled only as shown in arrangement "C" of figure 3-11. However, there are a number of possible variations in the assembly of the AN/SRT-15 transmitter bay. The four main arrangements are shown in "A₁", "A₂", "B₁", and "B₂" of figure 3-11. Note that the two stacks of this set may be adjoining or separated by as much as a 10-foot cable run. The AN/SRT-15 transmitter bay may be assembled with either a portion of the booster between the transmitter group and its mounting or one booster component on top of the other, either adjoining or separated from the transmitter stack. In adjoining arrangements, the booster stack may be installed on either right or left side of the transmitter stack. In any of the illustrations shown, it is possible to interchange the position of the two booster components, provided the necessary changes in the interconnecting cable lengths are made.

Similarly, the AN/SRT-16 transmitter bay may be assembled with either the two stacks adjoining or a maximum separation of 10 feet of cable. In an AN/SRT-16, either transmitter group may be connected for 500-watt operation. To obtain best use of the prefabricated inter-

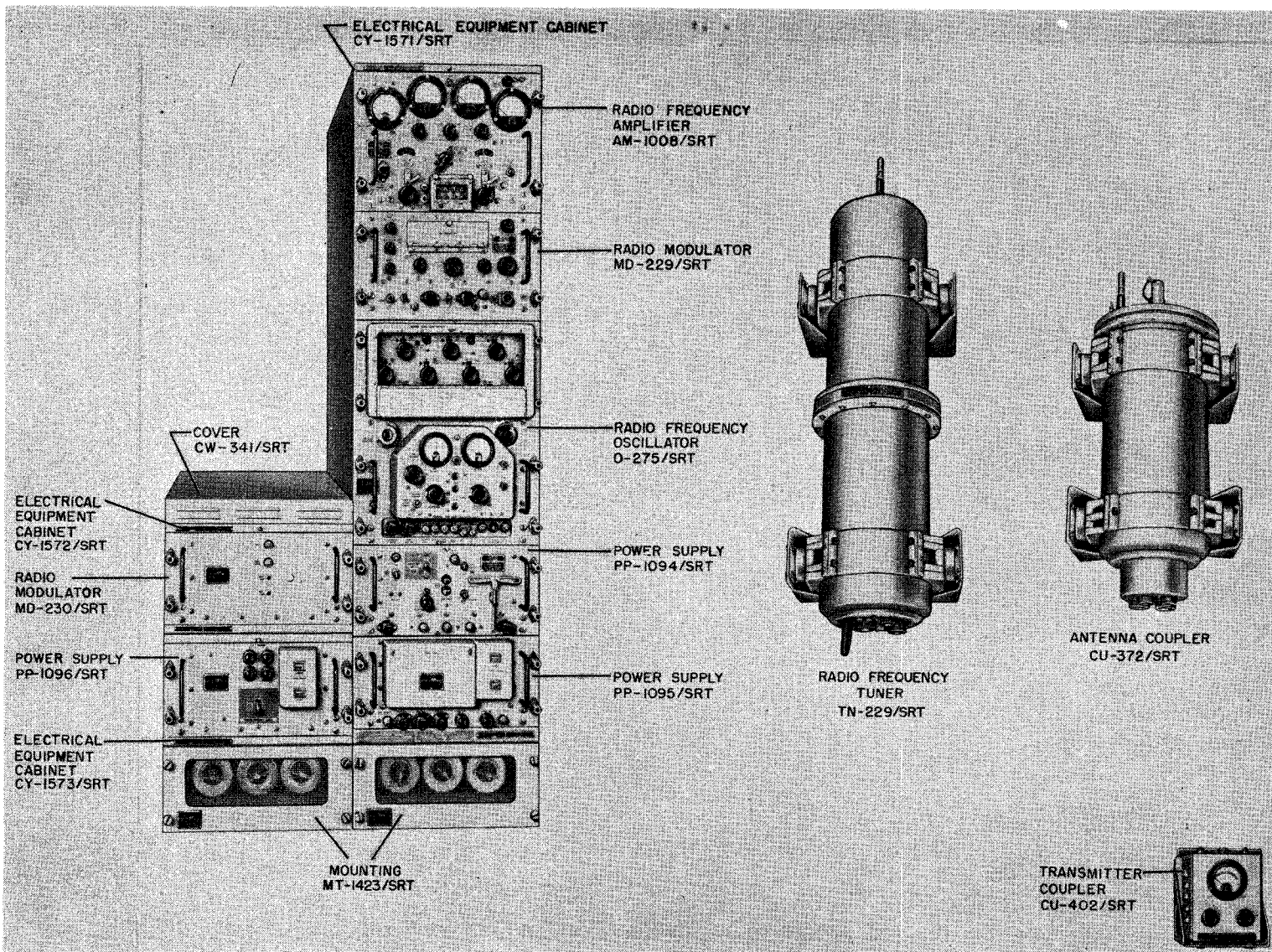

NAVSHIPS 92121(A)
AN/SRT-14, 14A, 15, 15A, 16, 16A

Figure 3-2. Simplified Pictorial View, Radio Transmitting Set AN/SRT-15

stack cables supplied with the equipment, the transmitter group mounted over the high level radio modulator should be designated the 500-watt stack, which corresponds to arrangement "D". Arrangement "E" is the same as "D", except that the stacks are separated a maximum of 10 feet. Arrangement "F" shows the booster components mounted adjoining the two transmitter stacks. In arrangements "D" and "E", the position of the 500-watt stack and the 100-watt stack may be transposed.

However, arrangements "A₁" for the AN/SRT-15 and "D" for the AN/SRT-16 are considered as the "standard" arrangements. When either of these two assemblies is used, the prefabricated cables supplied with the installation kit may be used for all connections between the two stacks. These cables should be run through the side cable entrances of the two adjoining mountings without the use of stuffing tubes. When any arrangement other than these two is chosen, the corresponding inter-stack cables must be fabricated by the installation personnel from standard Navy cable. The interconnecting cabling diagrams, figures 3-31 and 3-32, should be used as a guide.

When separated stack arrangements are employed for either the AN/SRT-15 or AN/SRT-16, 10 feet is considered to be the maximum separation between stacks. Greater separation can be used, but with a reduction of quality of transmission when the transmitter is in PHONE operation.

When the AN/SRT-15 transmitter assembly is installed with separated stacks as shown in arrangement A₂ of figure 3-11, two additional shock mounts are required for the rear of the booster stack. An installation such as that shown in arrangement "F", an alternate arrangement of the AN/SRT-16, requires one additional mounting, one booster cover, and four additional shock mounts in addition to the parts supplied for a standard arrangement "D" installation.

The Transmitter Coupler CU-402/SRT (load adjusting unit) should be mounted as close to the transmitter stack as possible. An ideal location of this unit is a mounting on the superstructure or some other suitably grounded member so that the controls of the transmitter coupler can be easily reached by an operator who is standing before the transmitter stack. The maximum distance between the transmitter stack and the transmitter coupler is set by the length of the two-conductor shielded cable, which is supplied with the installation material. This cable extends to a maximum of 12 feet from the cable entrance in the rear of the mounting at the base of the transmitter stack. Consult the outline drawing of the transmitter coupler (figure 3-27) for specific considerations.

b. ANTENNA TUNING EQUIPMENT.—The location of Antenna Coupler CU-372/SRT and Radio Frequency Tuner TN-229/SRT is primarily restricted by limitations of the lengths of the cables connecting these units with one another, with the antenna standoff termi-

TABLE 3-4. ANTENNA TUNING EQUIPMENT CRITICAL CABLE LENGTHS

CABLE DESCRIPTION	CABLE TYPE	CRITICAL LENGTH
Transmitter bay to antenna coupler control cable.	MHFA-24	500 ft max.
Transmitter bay to antenna coupler control cable.	MSCA-19	500 ft max.
Transmitter coupler to antenna coupler r-f cable.	RG-18/U	500 ft max.
Antenna coupler to r-f tuner r-f cable	RG-17/U 1st extrusion	Combined length of two cables should not exceed five feet.
Antenna coupler to antenna standoff terminal.	RG-17/U 1st extrusion.	

nal or down-lead and with the transmitter group. Table 3-4 lists the maximum lengths for the critical cables. The most critical cable length is the combined length of the two sections of RG-17/U first extrusion. As these cables, in effect, are radiating members, every effort should be made to locate them as far as possible from any other radiating or reflecting body as well as keeping their total length to a minimum.

(1) ANTENNA COUPLER CU-372/SRT.—The mounting arrangements of the Antenna Coupler CU-372/SRT make it possible to mount this unit in either a horizontal or vertical plane. The principal restrictions in locating this unit are the critical cable lengths as outlined in table 3-4. As previously stated, the combined length of the two RG-17/U first extrusion cables should be kept to a minimum and should not exceed five feet. If this value should exceed five feet, the effective antenna length as seen by the antenna tuning equipment will be so increased as to make the calibrated tuning information inaccurate and, at certain frequencies, to make satisfactory tuning impossible. An increased length of these cables also reduces the radiated power from the antenna element.

In addition to cable lengths, certain clearances must be observed for the connection or removal of the interconnecting cables as shown on the antenna coupler outline drawing, figure 3-28. Finally, to facilitate checking and replacing the charge of dry nitrogen gas, with which this unit is pressurized, the charge valve and pressure gauge mounted at one end should be accessible and visible.

(2) RADIO FREQUENCY TUNER TN-229/SRT.—The same restrictions on location that apply for the antenna coupler, as described above, also hold for the Radio Frequency Tuner TN-229/SRT. The r-f tuner outline drawing, figure 3-29, shows the required clearances.

c. REMOTE RADIOPHONE UNIT.—The location of the remote radiophone unit with respect to the transmitter bay location is limited only to a 1,000-foot maximum length of interconnecting cabling between the transmitter bay and radiophone unit. The choice of location should be determined solely by convenience of operation. In many installations, the radiophone unit may connect to the transmitter bay through a patch panel rather than by a direct cable.

4. ASSEMBLY PROCEDURE.

a. TRANSMITTER BAY.—The installation personnel should select the transmitter bay arrangement that will suit the allotted space. If sufficient room is available, arrangement "A₁" for the AN/SRT-15 and arrangement "D" for the AN/SRT-16 will be found to be most practical. An assembly procedure for the standard arrangements shown in figure 3-11 follows. The hardware, shock mounts, and other installation materials are provided with the equipment.

(1) AN/SRT-14 ARRANGEMENT "C".— Using the AN/SRT-14 transmitter bay outline drawing (figure 3-23) as a guide, prepare level, accurately drilled foundations for the bottom and rear of the transmitter group. Secure all four shock mounts (item 3 on figure 3-23) to the foundation deck but do not tighten the bolts completely. Remove the expendable base blocks from the mounting. Set the mounting on its set of shock mounts and check the spacing of the shock mounts by threading a 5/8-11 x 1-inch long hex head cap screw (item 4 on figure 3-23) through the mounting floor into each shock mount. If the tapped hole in the shock mount lies directly below the matching hole in the mounting floor, the mounting may be removed and the shock mounts tightened in place on the foundation. If holes in mounting and shock mounts are not aligned, the foundation must be redrilled as required to correct spacing of shock mounts.

The rear of the mounting contains four cable entrances: a rectangular entrance of 24 square inches in the rear wall; a 15-square inch entrance in the mounting floor; a two-inch diameter entrance through the rear gusset on each side. The cables required for the transmitting bay are shown on the AN/SRT-14 Interconnecting Cabling Diagram (figure 3-30). In this arrangement, the rear and bottom cable entrances may be used for interconnecting cables having an external run. The cable entries in the side gussets of the mounting are not used in AN/SRT-14 installations.

Although the rear wall cable entrance is large enough to accommodate all the external cables in the majority of AN/SRT-14 installations, both rear and bottom cable entrances may be used if the number of cables entering the mounting is exceptionally large or if clearance to the rear cable entrance is restricted.

Locate the two capacitors, C-701 and C-702, in the rear of the mounting. To facilitate cable handling, these capacitors and their clamps should be removed from the mounting during installation. Loosen and remove the two outside screws on each clamp; do not

allow the screws or lock washers to fall into the mounting while this is being done. Disconnect each of the leads from each capacitor. The two capacitors and their clamps may then be removed and set aside to be replaced when the mounting assembly is completed.

Using the AN/SRT-14 Interconnecting Cabling Diagram (figure 3-30) as a guide, connect one end of the interstack cable "A" to the indicated terminals of E-702 in the mounting. Run the cable under the flange holding the terminal board and feed the cable through the cable clamp mounted on the center of the angle iron behind the terminal board. Tighten the clamp and feed the free end of the cable through the upper left cable slot.

Before making cuts in any of the rear or bottom entrance cover plates, plan on paper the number and diameter of the external cables using each entrance.

Note

An r-f output for a receiver terminated in a BNC connector (P-609) is made available inside the transmitter bay. If an external receiver is to be connected to this output, provision should be made in the stuffing tube plan for the incoming coaxial cable from the receiver. The cable assembly consisting of R-RT4 and P-3315, found in the installation material, should also be considered in the stuffing tube plan.

Either stuffing tubes or cable clamps may be used to secure individual external cables to the entry plates. If the former method is chosen, 45° or 90° tubes may be used where clearance is limited or obstructions restrict the cable approach. In such installations, cover plate calculations must be based on the clearance required to install the stuffing tubes rather than the outer diameter of cables. Remove one or both cable entry cover plates as required and put a hole of proper diameter for each cable passing through the plate. If stuffing tubes are to be used, they should be secured to the cover plates by brazing or welding. Refer to BUSHIPS drawing 9-S-3980-L for specific details of stuffing tube installation.

With the exception of the jackets on coaxial cables, remove armor and jackets from the internal runs of all cables entering the mounting. Only the individual insulated conductors should enter the mounting. Strip the last 42 inches of all external cables terminating in the transmitter group cabinet.

Set the mounting in its approximate position. If stuffing tubes are used, feed the external cables through the stuffing tubes on the cable entrance cover plate. If straight stuffing tubes are used, the cable armor and sheath must extend at least 1/8 of an inch beyond the inner edge of the stuffing tube. Where 45° or 90° tubes are used, the armor and jacket should extend a minimum of 1/8 inch beyond the stuffing tube gland. The RG-8/U cable, R-RA1, and the coaxial cable from the receiver, if such applies, should extend 10 inches beyond the stuffing tube. Pack each stuffing tube with standard

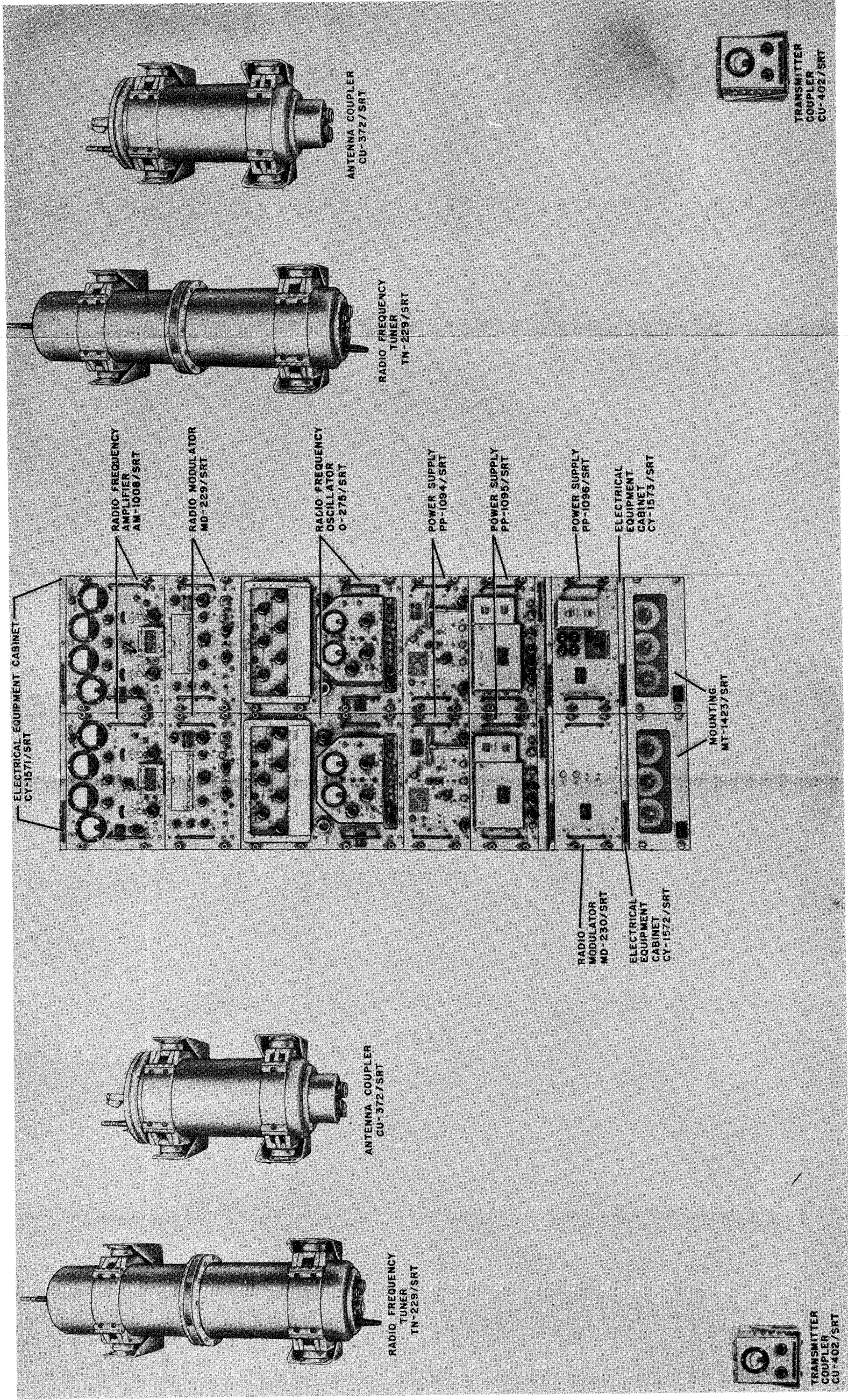

Figure 3-3. Simplified Pictorial View, Radio Transmitting Set AN/SRT-16

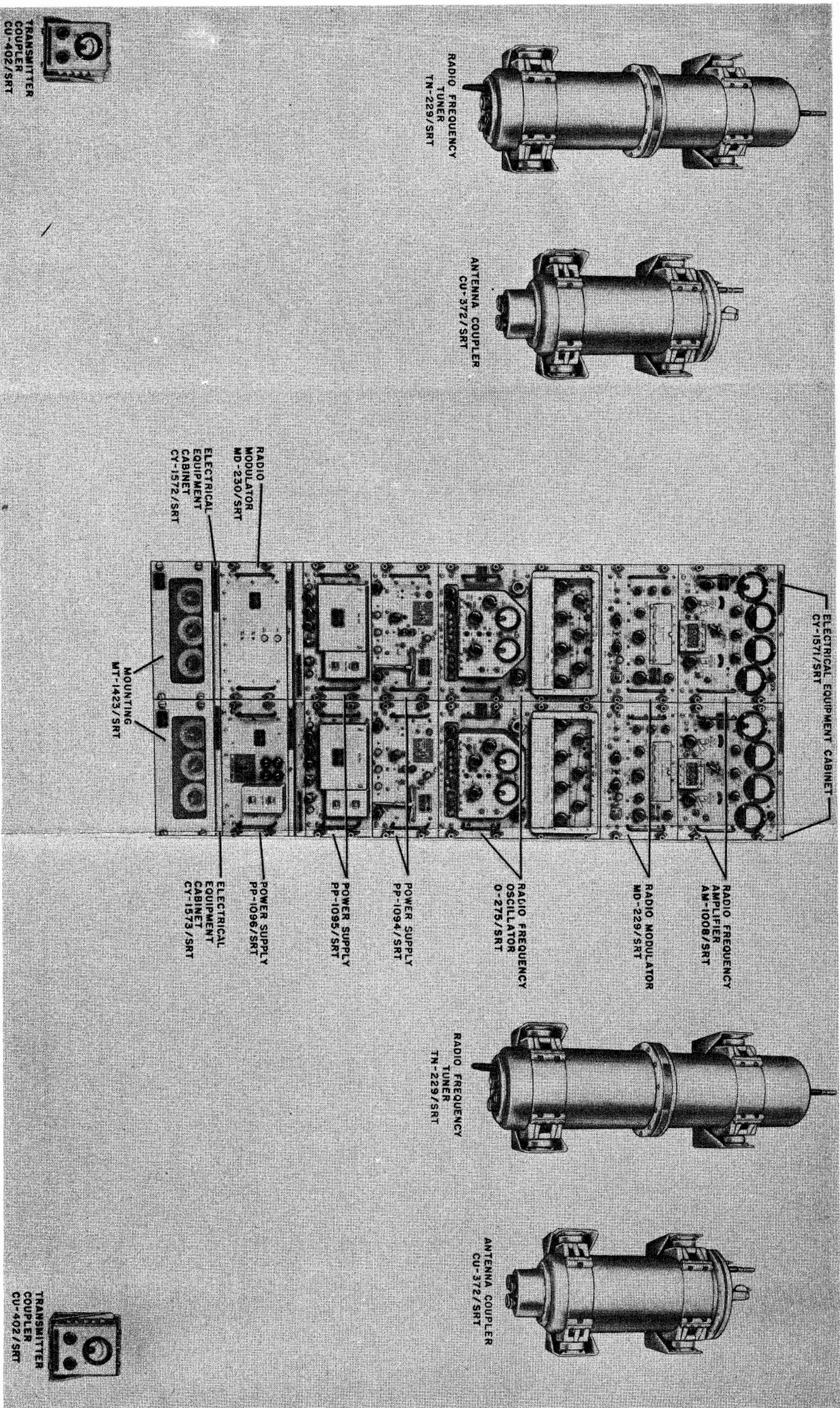

Figure 3-3. Simplified Pictorial View, Radio Transmitting Set AN/SRT-16

Navy packing, tighten the gland nuts, and seal the end of the gland nut with plastic sealing compound. If cable clamps with retaining lips are used, make certain that the end of the armor and jacket butt up against the inside of the lip. If clamps with retaining lips are not used, the armor and jacket must extend at least 1/8 inch beyond the clamp. Although no packing is required for cable clamps, the area between the clamp and the cable must be sealed with plastic sealing compound. BUSHIPS drawing 9-S-3980-L may be used as a guide for either stuffing tube or cable clamp installations. The individual conductors projecting from the inside of the cable entrance cover plate should be fed into the mounting and run forward to hang over the front screen of the mounting. Remove the UG-23B/U connector from the installation material and assemble it to the incoming RG-8/U cable (R-RA1), following the procedure outlined in the Cable Assembly Instruction (figure 3-12).

If such applies, a connector that will mate to a UG-89/U connector should be assembled to the coaxial cable incoming from a receiver (this connector is not supplied with the equipment). Replace the bottom cable entrance cover plate, securing it in place with the machine screws provided in the equipment. Repeat the above procedure for all cables entering the rear cable entrance.

The mounting is provided with two ground straps. Ground the mounting by securing the free end of each strap to a clean, unpainted portion of the foundation or ship's bulkhead. Then secure the mounting to the bottom shock mounts with the 5/8-11 x 1-inch long hex head cap screws and 5/8-inch lock washers provided in the installation kit (items 4 and 5 on figure 3-23). Pass the individual conductors of all incoming cables except the coaxial cables through the top left-hand cable slot and lace the portion in the mounting together with interstack cable "A". Since access to the mounting is

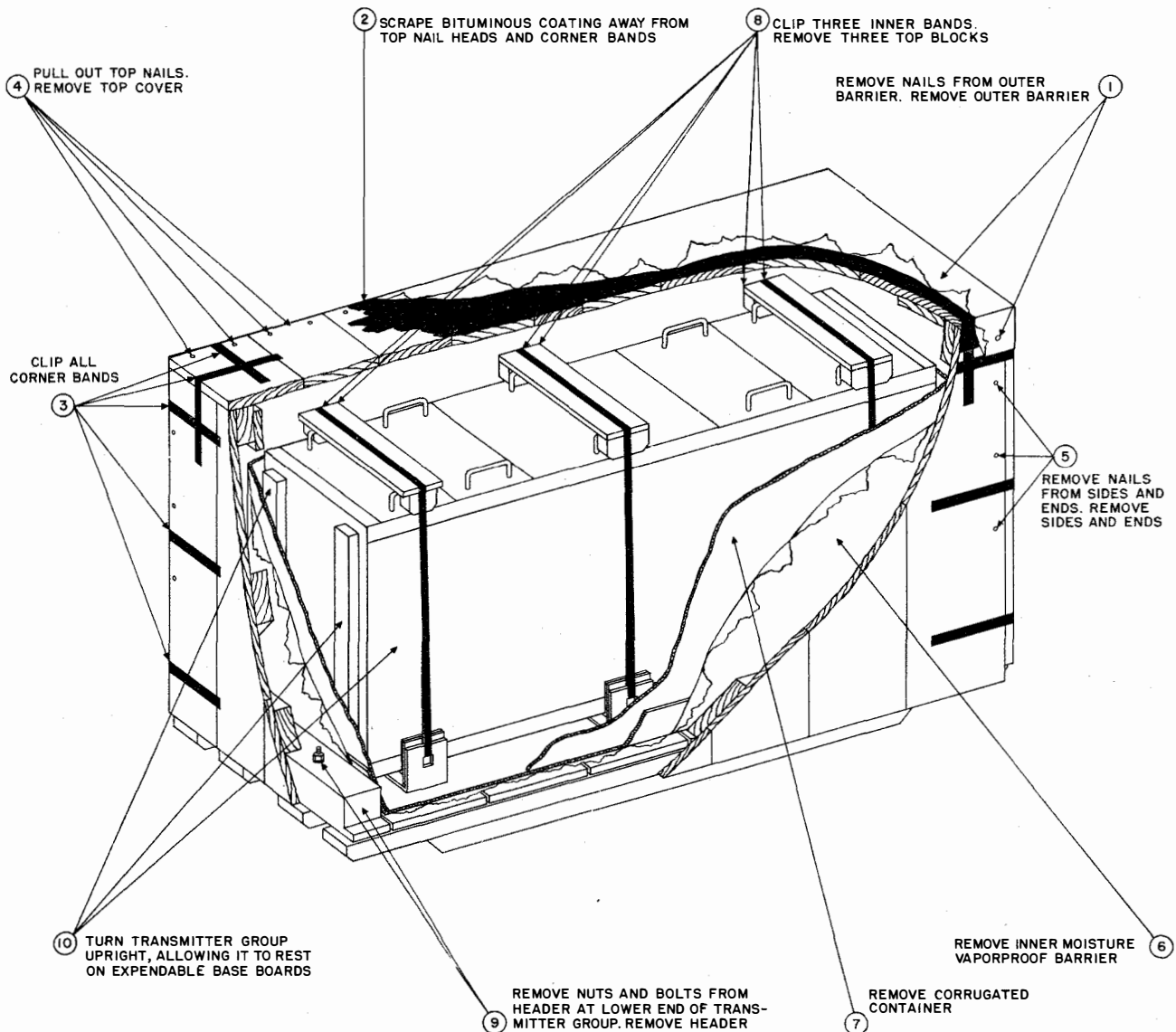

Figure 3-4. Transmitter Group OA-684/SRT, Unpacking Procedure

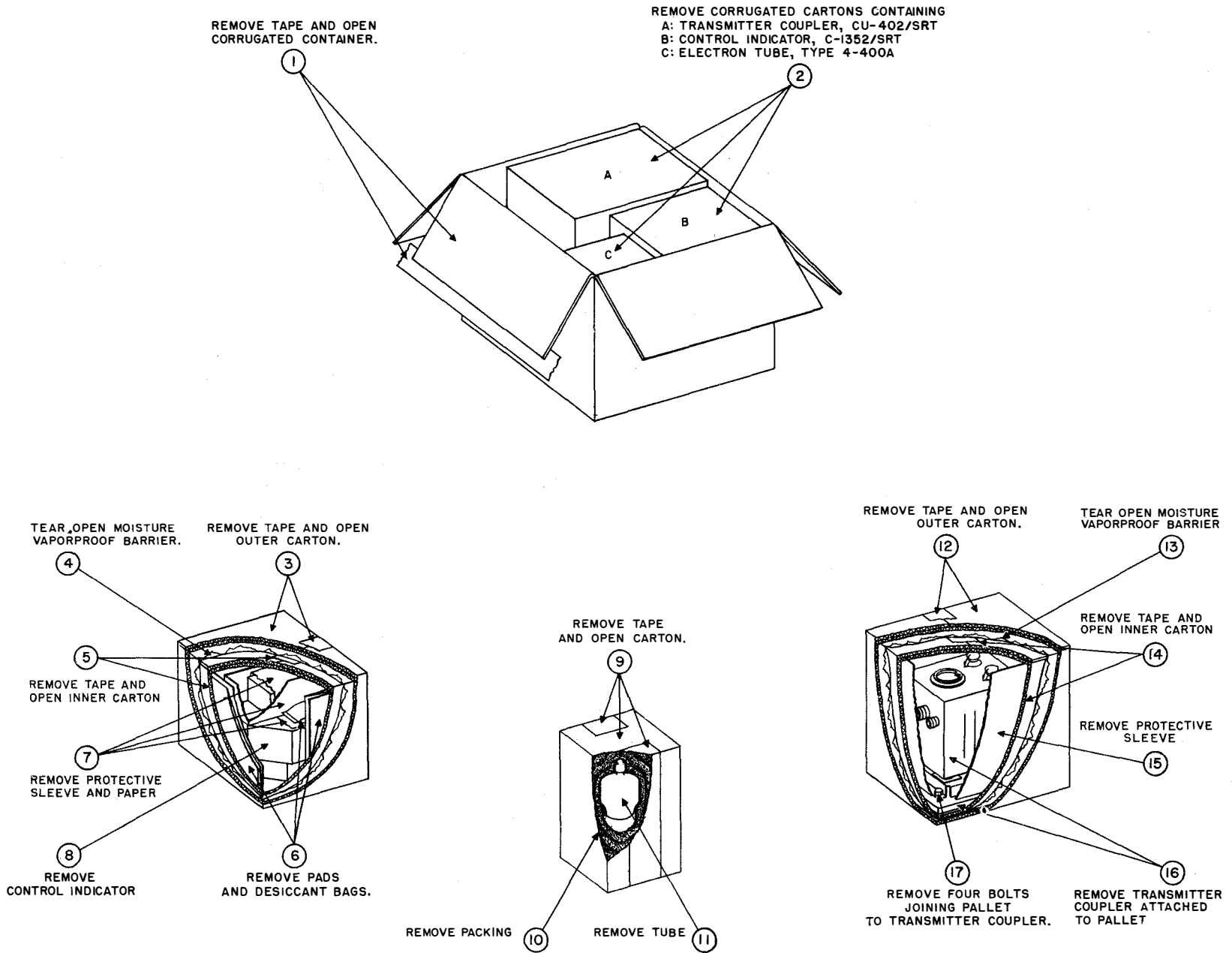

Figure 3-5. Transmitter Coupler CU-402/SRT, Control-Indicator C-1352/SRT, and Electron Tube 4-400A, Unpacking Procedure

very limited after other units have been mounted on top of it, all adjustments and connections in this unit should be made at this time. Then replace and reconnect the two capacitors, C-701 and C-702, in the mounting.

Secure the two sway mounts (item 14 on figure 3-23) in place on the bulkhead. Remove the top cover plate from the transmitter group cabinet.

Remove the five equipment drawers from the transmitter group cabinet by first loosening the captive screws that secure the drawers to the cabinet, using the special wrench mounted on the low voltage power supply front panel. Starting with the top drawer, pull the drawer forward on the rails until a stop on the rail is engaged. Disconnect the connectors of the retractable cabling from the connectors on the drawer. The connector assembly of the retractable cabling has an angle that should be latched on the post that is located on the transmitter group cabinet front above the top drawer, which, in turn, keeps the retractable cabling in its extended position. To complete the removal of the drawer, remove the two machine screws, one on each inner rail, that act as retainers for the latch in case of failure of the latch spring. Depress the latch on each inner rail and pull the chassis forward to clear the projection on the front of the rail.

WARNING

The drawer is now free to be removed entirely from the cabinet. Personnel removing the chassis should now be prepared to support the entire weight of the drawer.

Continue to pull the drawer forward until the inner slide disengages from the front rail roller, at which point the drawer will be completely free from the cabinet. Repeat the above process for each succeeding drawer. For all other drawers, the retractable cabling, after it is disengaged from the drawer, is returned to the rear of the cabinet.

Remove and discard the expendable base boards. Secure one eyebolt (item 8 on figure 3-23) in each of the tapped holes in the top of the transmitter group cabinet. Hoist the cabinet into position a few inches above the mounting.

CAUTION

Special care must be taken to avoid damaging the aligning tabs on the transmitter group side panels and the ventilation duct extensions on top of the mounting.

Block the cabinet in place a few inches above the top of the mounting. Two coaxial cables, terminating in connectors P-609 and P-610, are located, loose, in the bottom of the transmitter group cabinet. Pull these cables, with their connectors, down through the left-hand rear cable slot. Mate connectors P-609 and P-610, now in the mounting, with the corresponding connectors that have been affixed to the incoming cables, using the Interconnecting Cabling Diagram (figure 3-30) as a guide. Feed the other cables coming from the mounting through

the left cable slot in the bottom of the cabinet. Then carefully lower the cabinet into place on top of the mounting and secure it in place with the 1/2-13 x 1-inch cap screws and 1/2-inch lock washers (items 6 and 7 on figure 3-23) provided in the installation materials. Secure the back of the transmitter to the rear sway mounts with the 3/8-16 x 1-inch hex head cap screws and 3/8-inch lock washers provided in the installation materials (items 15 and 16 on figure 3-23). Remove the eyebolts from the top of the cabinet but do not replace the top cover plate until the interconnecting wiring has been completed. Remove the 10 leveling inserts (item 10 on figure 3-23) from the installation material and insert them in the tapped holes on the left side of the transmitter group cabinet. Similarly, insert the two leveling inserts (item 12 on figure 3-23) in the tapped holes on the left side of the mounting. Insert 12 plug buttons (item 13 on figure 3-23) in the leveling inserts. Insert the remaining 12 plug buttons (item 11 on figure 3-23) in the holes on the right side of the transmitter group cabinet and mounting.

(2) AN/SRT-15 ARRANGEMENT "A₁."—This method of assembly is considered the standard arrangement of the AN/SRT-15. Using the transmitter bay outline drawing (figure 3-24) as a guide, prepare level, accurately drilled foundations for the bottom and rear of the two stacks.

Secure all eight shock mounts (items 5 and 6 on figure 3-24) to the deck foundation but do not tighten the bolts completely. Remove the expendable base blocks from each mounting. Set each mounting on its set of shock mounts and check the spacing of the shock mounts by threading a 5/8-11 x 1-inch long hex cap screw (item 7 on figure 3-24) through the mounting floor into each shock mount. If the space between the two mountings measures 3/32 inch and the tapped hole in each shock mount lies directly below the matching hole in the mounting floor, the mounting may be removed and the shock mounts tightened in place on the foundation. If holes in mounting and shock mounts are not aligned, the foundation must be redrilled as required to correct spacing of shock mounts.

The rear of each mounting contains four cable entrances: a rectangular entrance of 24 square inches in the rear wall; a 15-square inch entrance in the mounting floor; a 2-inch diameter entrance through the rear gusset on each side. The cables required for each stack are shown on figure 3-31, the AN/SRT-15 Interconnecting Cabling Diagram. In this arrangement, the rear and bottom cable entrances may be used for interconnecting cables having an external run.

The cable entry in the gusset of each adjoining side is used for the passage of the prefabricated interstack cables supplied with the equipment. In the standard arrangement these unarmored, interstack cables are used in place of the Navy type cables indicated by asterisks on AN/SRT-15 Interconnecting Cabling Diagram (figure 3-31).

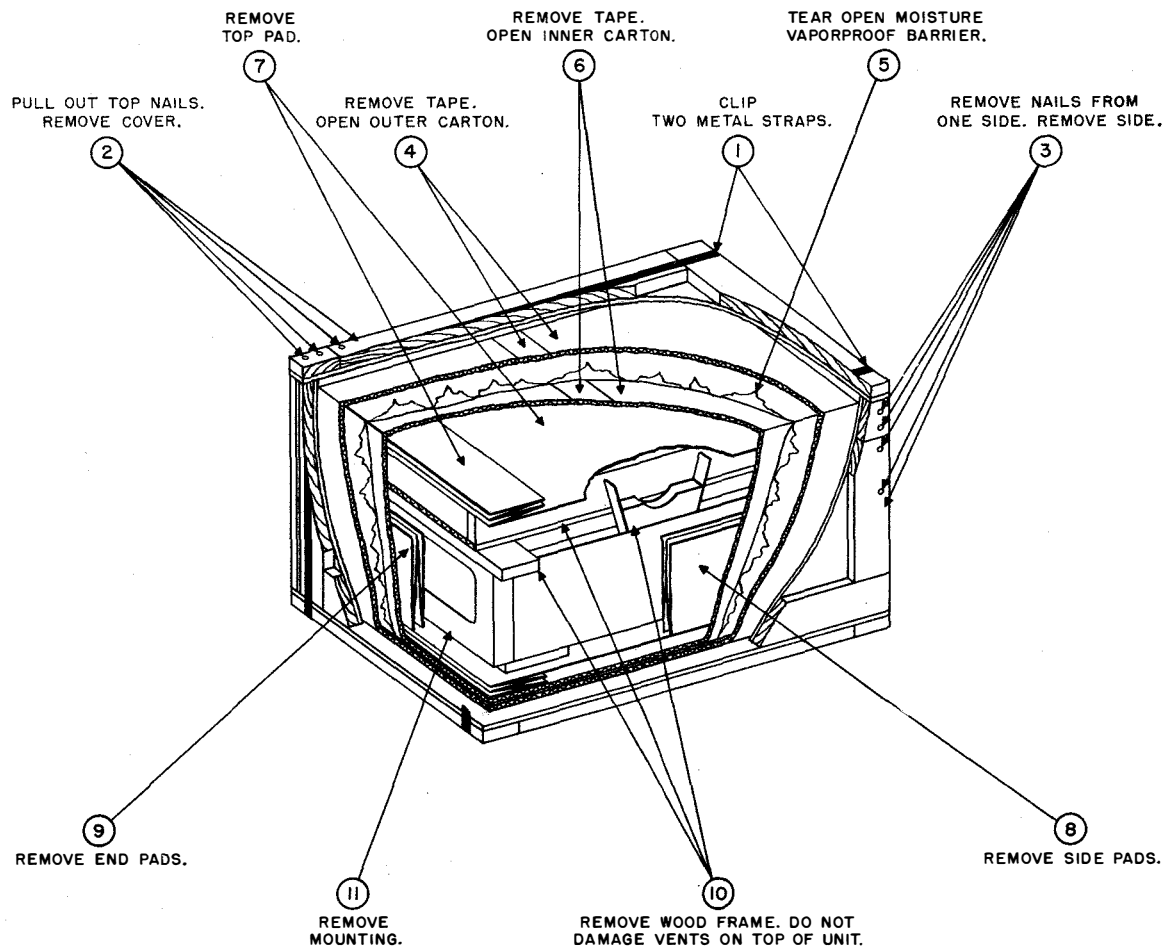

Figure 3-6. Mounting MT-1423/SRT, Unpacking Procedure

Although the rear wall cable entrance is large enough to accommodate all the external cables in the majority of AN/SRT-15 installations, both rear and bottom cable entrances may be used if the number of cables entering the mounting is exceptionally large or if clearance to the rear cable entrance is restricted.

Remove the side panels from the adjoining sides of the two mountings. In each side panel, cut a hole corresponding in diameter and location to that in the side gusset. Then replace the two side panels on the mountings. Remove two leveling inserts (item 20 on figure 3-24) from the installation materials box and thread them into the tapped holes on the left side of the right mounting.

Locate the two capacitors, C-701 and C-702, in the rear of each mounting. These capacitors and their clamps should be removed from the mounting during installation to facilitate cable handling. Loosen and remove the two outside screws on each clamp; do not allow the screws or lock washers to fall into the mounting while this is being done. Disconnect each of the leads from each capacitor. The two capacitors and their clamps may then be removed and set aside to be replaced when the mounting assembly is completed.

Using the AN/SRT-15 Interconnecting Cabling Diagram (figure 3-31) as a guide, connect the specified cables to the indicated terminals of E-702 in the right-hand mounting.

Note

See Terminal Board and Cable Entrance Data (figure 3-26) for location of terminal boards discussed in this section.

Run the cable going to the transmitter group (interstack cable "A") under the flange holding the terminal board and feed the cable through the cable clamp mounted on the center of the angle iron behind the terminal board. (See figure 3-13.) Tighten the clamp and feed the free end of the cable through the upper left cable slot. Run the cable going to the left mounting (interstack cable "B") under the flange and feed this cable through the cable clamp mounted on the left side of the angle iron behind the terminal board. Tighten the clamp and then pass the free end of this cable through the gusset entry on the left side of the mounting.

Set the left-hand mounting in its approximate position and feed the free end of cable from the right-hand mounting through the gusset entrance in the right side

of the mounting. Do not make the connections to E-702 in the left-hand mounting at this time and do not pass the cable through the clamp.

Before making cuts in any of the rear or bottom entrance cover plates, plan on paper the number and diameter of the external cables using each entrance. All incoming cables enter the right mounting except the three-phase power cable (R-RT2) that enters the left-hand mounting.

Note

An r-f output for a receiver terminated in a BNC connector (P-609) is made available inside the transmitter bay. If an external receiver is to be connected to this output, provision should be made in the stuffing tube plan for the incoming coaxial cable from the receiver. The cable assembly, consisting of R-RT13 and P-3315 located in the installation material, should also be included in the stuffing tube plan.

All interstack cables should enter the mountings through the gusset entrance. Either stuffing tubes or cable clamps may be used to secure individual external cables to the entry plates. If the former method is chosen, 45° or 90° tubes may be used where clearance is limited or obstructions restrict the cable approach. In such installations, cover plate calculations must be based on the clearance required to install the stuffing tubes rather than the outer diameter of cables. Remove one or both cable entry cover plates as required and cut a hole of proper diameter for each cable passing through the plate. If stuffing tubes are to be used, they should be secured to the cover plates by brazing or welding. Refer to BUSHIPS drawing 9-S-3980-L for specific details of stuffing tube installation.

With the exception of the jackets or coaxial shielding required for r-f cables, remove armor and jackets from the internal runs of all cables entering the mounting. Only the individual insulated conductors should enter the mounting. Strip the last 42 inches of all external cables terminating in the transmitter group cabinet and the last 38 inches of the three-phase power cable (R-RT2).

Set the mounting in its approximate position. If stuffing tubes are used, feed the external cables through the stuffing tubes on the cable entrance cover plate. If straight stuffing tubes are used, the cable armor and sheath must extend at least 1/8 of an inch beyond the inner edge of the stuffing tube. Where 45° or 90° tubes are used, the armor and jacket should extend a minimum of 1/8 inch beyond the stuffing tube gland. The RG-8/U cable, R-RA1, and the coaxial cable from the receiver, if such applies, should extend 10 inches beyond the stuffing tube. Pack each stuffing tube with standard Navy packing, tighten the gland nut, and seal the end of the gland nut with plastic sealing compound. If cable clamps with retaining lips are used, make certain that the end of the armor and jacket

butt up against the inside of the lip. If clamps with retaining lips are not used, the armor and jacket must extend at least 1/8 inch beyond the clamp. Although no packing is required for cable clamps, the area between the clamp and the cable must be sealed with plastic sealing compound. BUSHIPS drawing 9-S-3980-L may be used as a guide for either stuffing tube or cable clamp installations.

The individual conductors projecting from the inside of the cable entrance cover plate should be fed into the mounting and run forward to hang over the front screen of the mounting. Remove the UG-23B/U connector from the installation material and assemble it to the incoming RG-8/U cable (R-RA1) following the procedures outlined in the Cable Assembly Instruction (figure 3-12). If such applies, a connector that will mate to a UG-89/U connector should be assembled to the coaxial cable incoming from a receiver (this connector is not supplied with the equipment). Replace the bottom cable entrance cover plate, securing it in place with the machine screws provided in the equipment. Repeat the above procedure for all cables entering the rear cable entrance.

Feed the interstack cables (cables "C" and "F") from the transmitter group to the two booster units through the left-hand gusset entrance, and up through the left-hand cable slot. The two cables should protrude above the top of the right mounting according to the length required to fan out on the transmitter group terminal boards. Feed interstack cable "G" through the left side panel entrance of the right-hand mounting and pass the cable up through the area between the left-side panel and the structural members of the mounting. Cable "G" should protrude above the top of the right mounting according to the length required to connect to the transmitter group terminal board (E-608). Make certain that the base mount to base mount cable is not clamped tightly in the left mounting and then slide the two mountings slightly apart. Using abrasion-resistant tape, wrap interstack cables "C" and "F" together at the point where they pass through the side panel of the right mounting for a length of four to six inches centered at the side panel. Similarly, wrap interstack cable "G" and the base mount to base mount cable (cable "B") together. Feed cables "C" and "F" through the right side panel of the left-hand mounting and then up through the area between the side panel and the structural members of the left mounting. Feed the other two cables through both the right side panel and right side gusset entrance of the left mounting. Slide the two mountings into their approximate positions so that the two side panels are adjoining. Feed interstack cable "G" across the floor of the left mounting, through the left side gusset entrance, and then up through the area between the left side panel and the structural members of the mounting. In the left mounting, remove the screw holding the cable clamp on the left side of the angle iron behind the terminal board, E-702, and mount the clamp

Paragraph 4 a (2)

AN/SRT-14, 14A, 15, 15A, 16, 16A

in the corresponding tapped hole on the right side of the angle iron. Pass cable "B" through this clamp, under the angle iron to E-702 and tighten the clamp. Using the Interconnecting Cabling Diagram, figure 3-31, as a guide, make the indicated connections on E-702 in the left-hand mounting.

Each mounting is provided with two ground straps. Ground the mounting by securing the free end of each strap to a clean, unpainted portion of the foundation or ship's bulkhead. Thread the adjustable inserts in or out until the space between the two mountings is 3/32 inch. Then secure each mounting to the bottom shock mounts with the 5/8-11 x 1-inch long hex head cap screws and 5/8-inch lock washers provided in the installation kit (items 7 and 8 on figure 3-24). Using the 5/16-18 x 2-inch long hex head cap screws, 5/16-inch lock washers and 5/16-inch nuts provided in the installation materials (items 11, 12, and 13 on figure 3-24), secure the front and rear of the two mountings together.

Lace all the conductors of all cables, except the interstack and the coaxial cables, entering the right mounting together and pass them through the upper left cable slot on the top of the right mounting. The three-phase power cable (R-RT2) entering the left-hand mounting should be fed through the cable slot on the left side of the mounting frame. Then replace and reconnect the two capacitors, C-701 and C-702, in each mounting.

Secure the two sway mounts (item 22 on figure 3-24) in place on the bulkhead foundation. Remove the top cover plate from the transmitter group cabinet.

Remove the five equipment drawers from the transmitter group cabinet, by first loosening the captive screws that secure the drawers to the cabinet, using the special wrench mounted on the low voltage power supply front panel. Starting with the top drawer, pull the drawer forward on the rails until a stop on the rail is engaged. Disconnect the connectors of the retractable cabling from the connectors on the drawer. The connector assembly of the retractable cabling has an angle that should be latched on the post that is located on the transmitter group cabinet front above the top drawer, which, in turn, keeps the retractable cabling in its extended position. To complete the removal of the drawer, remove the two machine screws, one on each inner rail, that act as retainers for the latch in case of failure of the latch spring. Depress the latch on each inner rail and pull the chassis forward to clear the projection on the front of the rail.

WARNING

The drawer is now free to be removed entirely from the cabinet. Personnel removing the chassis should now be prepared to support the entire weight of the drawer.

Continue to pull the drawer forward until the inner slide disengages from the front rail roller, at which

point the drawer will be completely free from the cabinet. Repeat the above process for each succeeding drawer. For all other drawers, the retractable cabling, after it is disengaged from the drawer, is returned to the rear of the cabinet.

Remove and discard the expendable base boards. Secure one eyebolt (item 16 on figure 3-24) into each of the four tapped holes on the top of the transmitter group cabinet. Hoist the cabinet into position a few inches above the right-hand mounting.

CAUTION

Special care must be taken to avoid damaging the aligning tabs of the transmitter group and the ventilation duct extensions on top of the mounting.

Block the cabinet in place a few inches above the mounting. The coaxial cables, terminating in connectors P-609 and P-610, are located, loose, in the bottom of the transmitter group cabinet. Pull these cables, with their connectors, down through the left-hand rear cable slot. Feed interstack cable "G" coming from the mounting through area on the bottom left side of the cabinet where terminal board E-608 is mounted. Mate connectors P-609 and P-610, now in the mounting, with the corresponding connectors which have been affixed to the incoming cables, using the Interconnecting Cabling Diagram (figure 3-31) as a guide. Feed the other cables coming from the right-hand mounting through the left-hand cable slot in the bottom of the cabinet. Then carefully lower the cabinet into place on top of the mounting and secure it in place with the 1/2-13 x 1-inch long cap screws and 1/2-inch lock washers (items 9 and 10 on figure 3-24) provided in the installation materials box. Remove the eyebolts from the top of the cabinet but do not replace the top cover plate until the interconnecting wiring has been completed. Remove four leveling inserts (item 18 on figure 3-24) from the installation material and thread them into the four lowest tapped holes on the left side of the transmitter group cabinet. Thread the inserts in or out until they project 3/32 inch from the side of the cabinet.

Remove the high voltage power supply drawer from its cabinet in the same manner as described for the drawers in the transmitter group cabinet. Resting the front of the cabinet on the front of the mounting, feed the interstack cable "C" coming from the left-hand mounting, through the area between the right side panel of the high voltage power supply cabinet and its structural members, and into the cabinet through the right side entry. Feed interstack cable "F" through the area between the cabinet right side panel and its structural members and out of the top of the cabinet. Feed the interstack cable "G", coming from the left side of the mounting, along the left side of E-1404 and out of the top of the cabinet. Feed the three-phase power cable (R-RT2) through the left-hand cable slot in the bottom of the high voltage supply cabinet. Lower the

cabinet into place so that all aligning tabs are inside the side panels. Secure the cabinet to the mounting with the hex head cap screws and lock washers (items 9 and 10 on figure 3-24) provided in the installation materials box. Feed the high voltage power supply to the high level modulator interstack cable (cable "D") from the high voltage power supply cabinet, through the right side entry at the rear, up through the area between the right side panel and the cabinet structure, and out of the top of the cabinet, making sure the cable protrudes far enough to fan out to the high level modulator cabinet terminal boards. Lace together cables "D" and "F".

Remove the high level radio modulator from its cabinet. Resting the front of the cabinet on the high voltage power supply, feed the interstack cables "D" and "F" coming from the power supply through the area between the high level modulator cabinet right side panel and its structure and into the cabinet through the right side entry. Feed interstack cable "G" into the area of the cabinet occupied by E-1408. Lower the modulator cabinet into place, making certain that all aligning tabs are inside the side panels. Secure the modulator cabinet to the high voltage power supply cabinet with the cap screws and lock washers (items 9 and 10 on figure 3-24) provided in the installation materials box. Feed the high level modulator to the high voltage power supply interstack cable (cable "E")

from the location of terminal board E-1408, in the high level modulator, down in the corresponding area of the high voltage power supply cabinet to terminal board E-1404. Temporarily lace this cable to the cabinet structure for support.

Bolt the two stacks together with the hex head cap screws, lock washers and nuts (items 11, 12, and 13 on figure 3-24). Where the spacing between the stacks is excessive, thread the inserts out until 5/32 inch of it projects from the side of the frame and then take up the rest of the spacing by tightening the bolts holding the two stacks together. Secure the back of the transmitter group cabinet to the sway mounts with the 3/8-16 x 1-inch long hex head cap screws and 3/8-inch lock washers (items 23 and 24 on figure 3-24) provided with the installation materials. Thread the remaining two leveling inserts (item 20 on figure 3-24) into the left side of the left mounting. Thread the remaining 10 leveling inserts (item 18 on figure 3-24) into the left side of the booster cabinets and the remaining tapped holes in the left side of the transmitter group cabinet. Insert 12 plug buttons (item 21 on figure 3-24) in the leveling inserts. Insert 12 plug buttons (item 19 on figure 3-24) in the holes on the right side of the transmitter group cabinet and mounting.

(3) AN/SRT-16 ARRANGEMENT "D".—This method of assembly is considered the standard arrangement of the AN/SRT-16. Using the transmitter bay

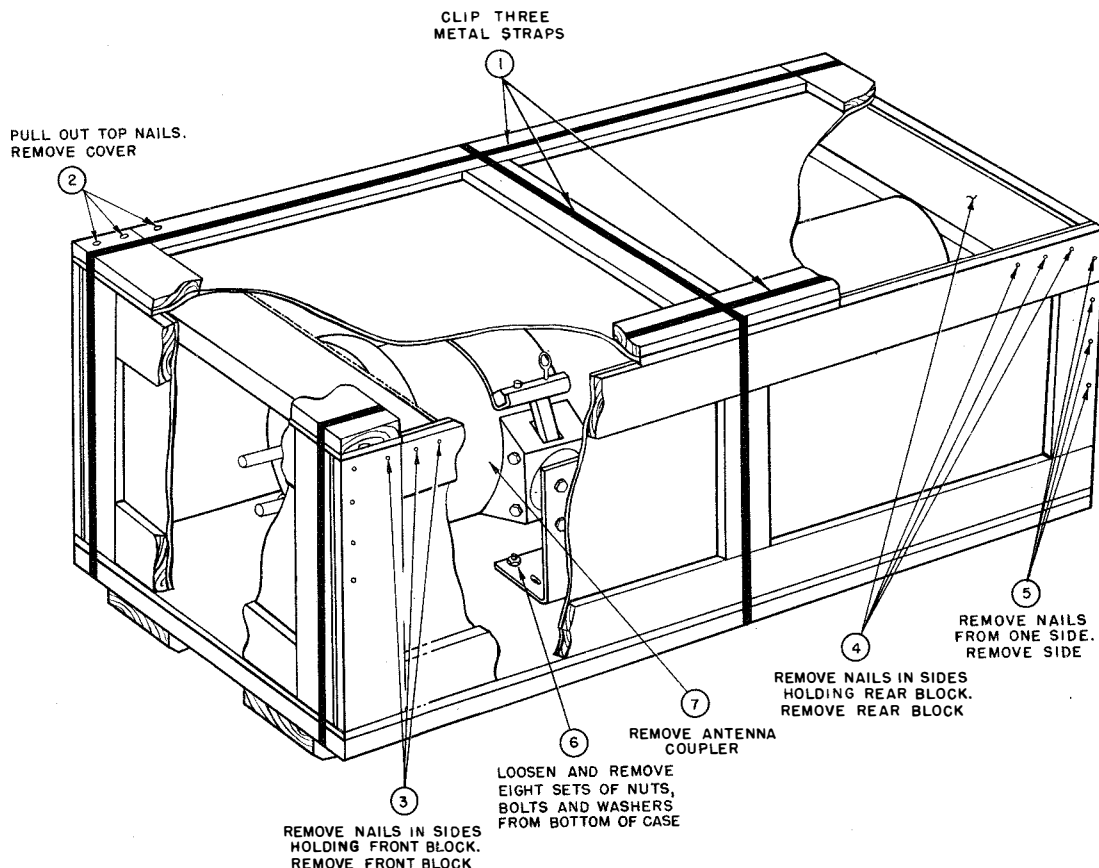

Figure 3-7. Antenna Coupler CU-372/SRT, Unpacking Procedure

Paragraph 4 a (3)

AN/SRT-14, 14A, 15, 15A, 16, 16A

outline drawing (figure 3-25) as a guide, prepare level, accurately drilled foundations for the bottom and rear of the two stacks.

Secure all eight shock mounts (item 4 on figure 3-25) to the deck foundation but do not tighten the bolts completely. Remove the expendable base blocks from each mounting. Set each mounting on its set of shock mounts and check the spacing of the shock mounts by threading a 5/8-11 x 1-inch long hex head cap screw (item 5 of figure 3-25) through the mounting floor into each shock mount. If the space between the two mountings measures 3/32 inch and the tapped hole in each shock mount lies directly below the matching hole in the mounting floor, the mounting may be removed and the shock mounts tightened in place on the foundation. If holes in mounting and shock mounts are not aligned, the foundation must be redrilled as required to correct spacing of shock mounts.

The rear of each mounting contains four cable entrances: a rectangular entrance of 24 square inches in the rear wall; a 15-square inch entrance in the mounting floor; a two-inch diameter entrance through the rear gusset on each side. The cables required for each stack are illustrated in the AN/SRT-16 Interconnecting Cabling Diagram (figure 3-32). In this arrangement the rear and bottom cable entrances may be used for interconnecting cables having an external run.

The cable entry in the gusset of each adjoining side is used for the passage of the prefabricated interstack cables supplied with the equipment. In the standard arrangement these unarmored, interstack cables are used in place of the Navy-type cables indicated by asterisks on the AN/SRT-16 Interconnecting Cabling Diagram (figure 3-32).

Although the rear wall cable entrance is large enough to accommodate all the external cables in the majority of AN/SRT-16 installations, both rear and bottom cable entrances may be used if the number of cables entering the mounting is exceptionally large or if clearance to the rear cable entrance is restricted.

Where corresponding cables serving the two transmitter groups have completely parallel runs, the two individual cables may be combined into a single larger cable. For example, the two TTHFWA-1-1/2 cables, carrying teletype input to the two transmitter groups (figure 3-32), may be replaced by a single TTHFWA-3 if the far ends of both cables terminate at the same point. The TTHFWA-3 may enter either of the two stacks; the two individual conductors feeding the other stack should be run through the gusset cable entrances in the mounting side panels.

Oven heaters in both transmitter groups are fed by a single DSGA-3 line (R-RT3). (See figure 3-32.) This cable is run into the left-hand mounting and terminates on E-602, terminals 21 and 22. Two conductors of the transmitter group to the transmitter group interstack cable are used to connect the heaters in the left transmitter group in parallel with those of the right.

Remove the side panels from the adjoining sides of the two mountings. In each side panel cut a hole corresponding in diameter and location to that in the side gusset. Then replace the two side panels on the mountings. Remove two leveling inserts (item 16 on figure 3-25) from the installation materials box and thread them into the tapped holes on the left side of the right mounting. Locate the capacitors, C-701 and C-702, in the rear of each mounting. These capacitors and their clamps should be removed from the mounting during installation to facilitate cable handling. Loosen and remove the two outside screws on each clamp; do not allow the screws or lock washers to fall into the mounting while this is being done. Disconnect each of the leads from each capacitor. The two capacitors and their clamps may then be removed and set aside to be replaced when the mounting assembly is completed.

Using the AN/SRT-16 Interconnecting Cabling Diagram (figure 3-32) as a guide and assuming the left-hand stack to be the 500-watt stack, connect one end of the base mount to base mount and base mount to transmitter group interstack cables (interstack cables "L" and "N") to the indicated terminals on E-702 in the right mounting.

Note

See Terminal Board and Cable Entrance Data (figure 3-26) for location of terminal boards discussed in this section.

In the right mounting, remove the screw holding the cable clamp in the center of the angle iron behind the terminal board, E-702, and mount the clamp in the corresponding tapped hole on the right side of the angle iron. Run the cable going to the right transmitter (interstack cable "L") under the flange holding the terminal board and feed the cable through the cable clamp mounted on the right side of the angle iron. (See figure 3-13.) Tighten the clamp and feed the free end of the cable along the floor of the right mounting, through the right side gusset entry and up through the space between the right side panel and the structure of the mounting. Run the cable going to the left mounting (interstack cable "N") under the flange and feed this cable through the cable clamp mounted on the left side of the angle iron behind the terminal board. Tighten the clamp, and then pass the free end of this cable through the gusset entry on the left side of the mounting.

Set the left-hand mounting in its approximate position and feed the free end of the base mount to the base mount cable, cable "N", through the gusset entrance in the right side of this mounting. Do not make the connections to E-702 in the left-hand mounting at this time and do not pass the cable through the clamp.

Before making cuts in any of the rear or bottom entrance cover plates, plan on paper the number and diameter of the external cables using each entrance.

Note

An r-f output for a receiver terminated in a BNC connector (P-609) is made available in-

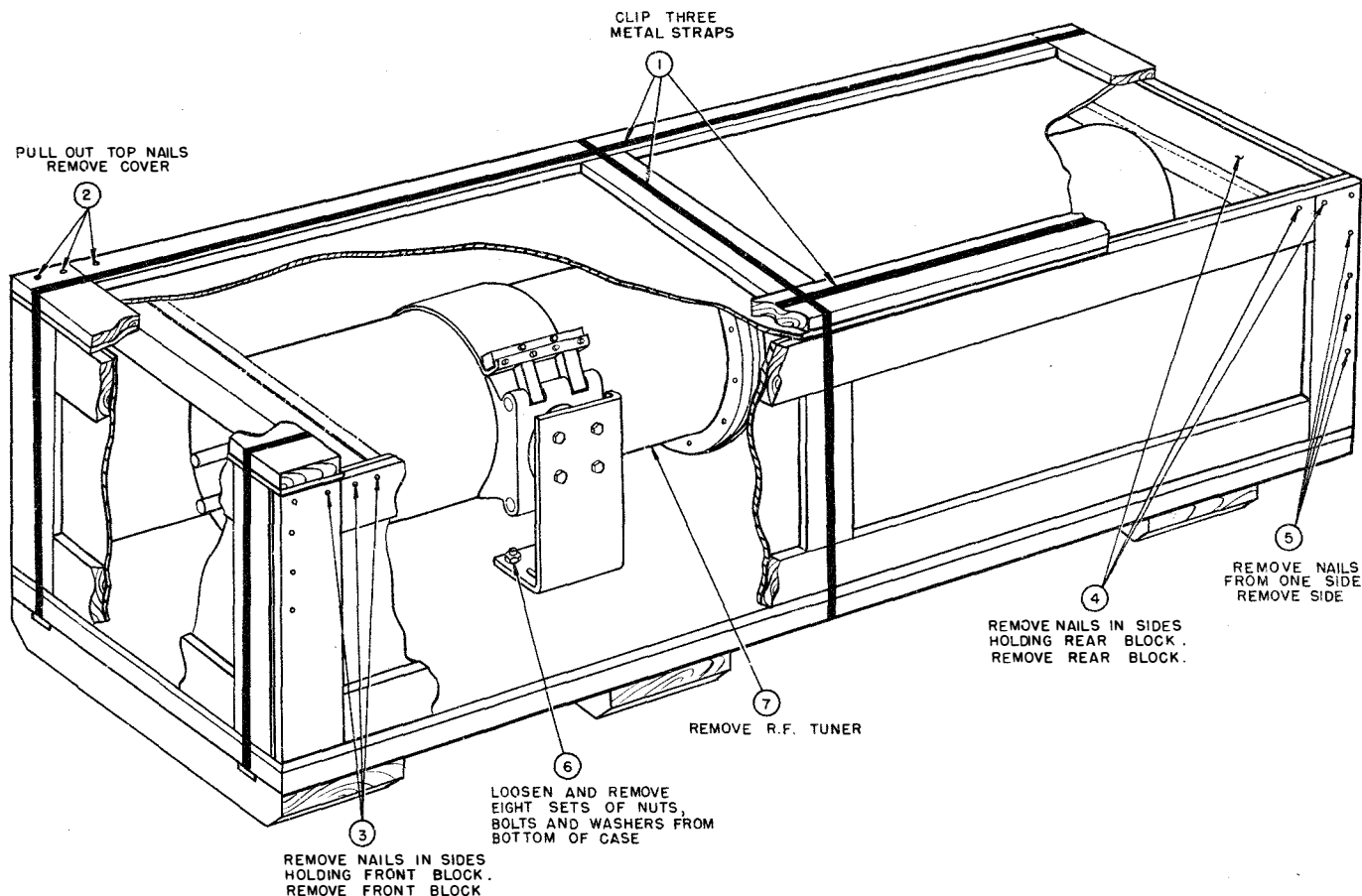

Figure 3-8. Radio Frequency Tuner TN-229/SRT, Unpacking Procedure

side. the transmitter bay. If an external receiver is to be connected to this output, provision should be made in the stuffing tube plan for the incoming coaxial cable from the receiver. Two cable assemblies, each consisting of R-RT15 and P-3315, located in the installation material, should also be included in the stuffing tube plan.

All interstack cables should enter the mountings through the gusset entrance. Either stuffing tubes or cable clamps may be used to secure individual external cables to the entry plates. If the former method is chosen, 45° or 90° tubes may be used where clearance is limited or obstructions restrict the cable approach. In some installations cover plate calculations must be based on the clearance required to install the stuffing tubes rather than the outer diameter of cables. Repeat the following procedure for each of the two mountings. Remove one or both cable entry cover plates as required and cut a hole of proper diameter for each cable passing through the plate. If stuffing tubes are to be used, these fixtures should be secured to the cover plates by brazing or welding. Refer to BUSHIPS drawing 9-S-3980-L for specific details of stuffing tube installation.

With the exception of the jackets on coaxial cables, remove armor and jackets from the internal runs of all cables entering the mounting. Only the individual insulated conductors should enter the mounting. Strip the last 75 inches of all external cables terminating in the transmitter group cabinet and 38 inches of the three-phase power cable (R-RT2) connected to the high voltage power supply cabinet.

Set the mounting in its approximate position. If stuffing tubes are used, feed the external cables through the stuffing tubes mounted on the cable entrance cover plate. If straight stuffing tubes are used, the cable armor and sheath must extend at least 1/8 inch beyond the inner edge of the stuffing tube. Where 45° or 90° tubes are used, the armor and jacket should extend a minimum of 1/8 inch beyond the stuffing tube gland. The two RG-8/U cables (1-R-RA1 and 2-R-RA1) and the two coaxial cables from receivers, if such applies, should extend 10 inches beyond the stuffing tube. Pack each stuffing tube with standard Navy packing, tighten the gland nuts, and seal the end of the gland nut with plastic sealing compound. If cable clamps with retaining lips are used, make certain that the end of the armor and jacket butt up against the inside of the lip.

3 Section
Paragraph 4 a (3)

NAVSHIPS 92121(A)
AN/SRT-14, 14A, 15, 15A, 16, 16A

INSTALLATION

If cable clamps with retaining lips are not used, the armor and jacket must extend at least 1/8 inch beyond the clamp. Although no packing is required for cable clamps, the area between the clamp and the cable must be sealed with plastic sealing compound. BUSHIPS drawing 9-S-3980-L may be used as a guide for either stuffing tube or cable clamp installations.

The individual conductors projecting from the inside of the cable entrance cover plates should be fed into the mounting and run forward to hang over the front screen of the mounting. Remove the two UG-23B/U connectors from the installation material and assemble them to the two incoming RG-8/U cables following the procedure outlined in the Cable Assembly Instruction (figure 3-12). If such applies, two connectors that will mate to UG-89/U connectors should be assembled to the two coaxial cables incoming from receivers (these connectors are not supplied with the equipment). Replace the bottom cable entrance cover plates,

securing them in place with the machine screws provided in the equipment. Repeat the above procedure for all cables entering the rear cable entrance.

Feed the interstack cable from the high voltage power supply to the high level modulator and to the 500-watt transmitter group (interstack cables "H" and "J") in through the left gusset entrance, across the floor of the right mounting, through the right side gusset entrance, and up through the area between the right side panel and the structure of the right mounting. These two cables should protrude above the top of the right-hand mounting according to the length required to fan out on the high voltage power supply terminal boards. In the same manner feed the interstack cable between the two transmitter groups (cable "P") through the right side mounting, except this cable should protrude above the top of the right-hand mounting far enough to pass through the high voltage power supply cabinet, and then be able to fan out on

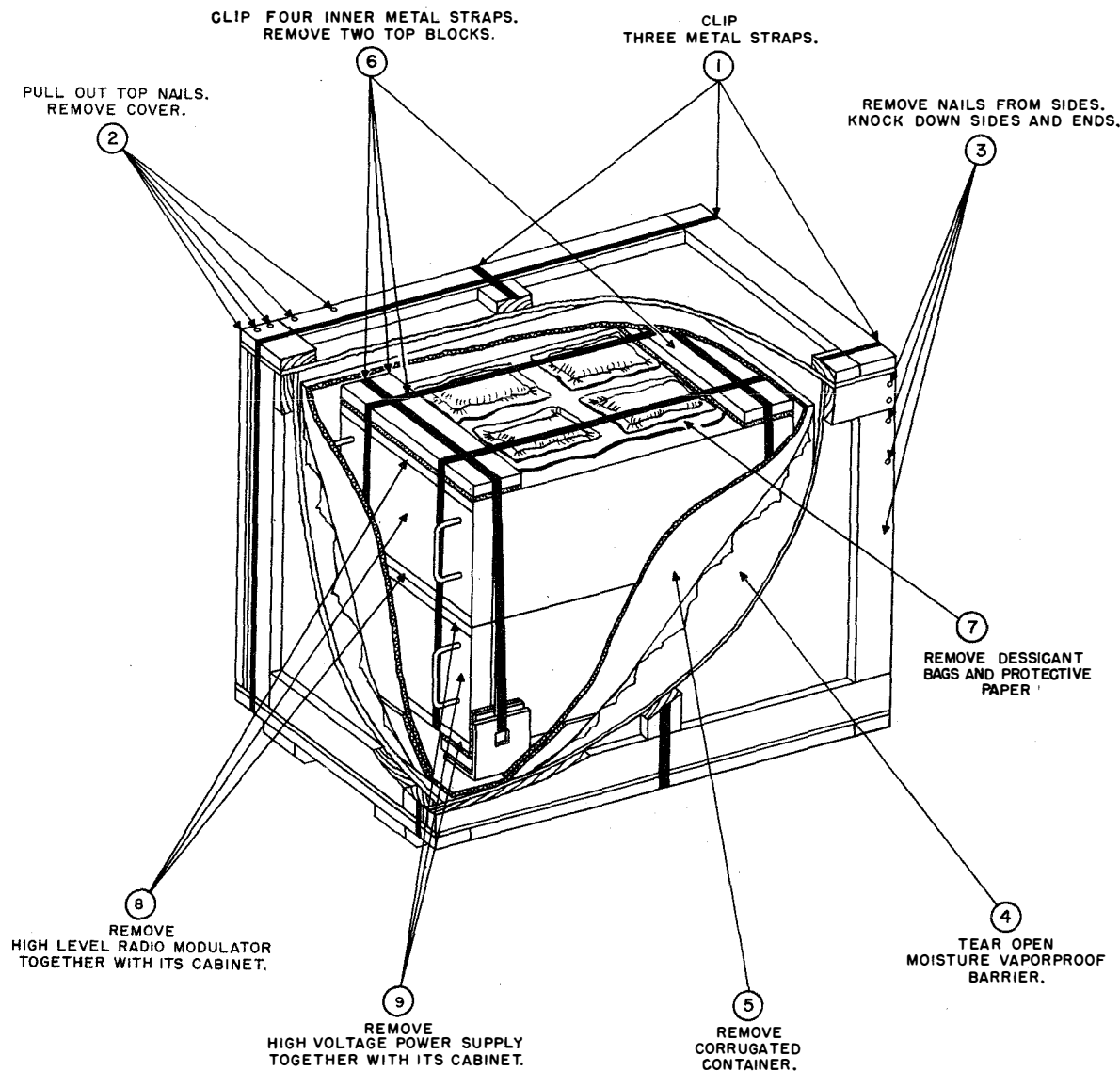

Figure 3-9. Radio Modulator-Power Supply OA-685/SRT, Unpacking Procedure

the terminal boards of the transmitter group, which will mount on top of the high voltage power supply. Feed interstack cable "K" through the left side panel entrance of the right mounting and pass the cable up through the area between the left side panel and the structure of the mounting. Cable "K" should protrude above to the top of the right mounting according to the length required to connect to the high voltage power supply terminal board (E-1404). Make certain that the base mount to base mount cable is not clamped in the left mounting and then slide the two mountings slightly apart. Using abrasion-resistant tape, wrap interstack cables "H", "J", and "P" together at the point where they pass through the side panel of the right mounting for a length of three inches to the right of this point and one inch to the left of this point. Wrap tape around cable "N" for a length of three inches on both sides of the point. Wrap tape around cable "K" for a length of three inches to the left of the point and one inch to the right of the point.

Feed cables "H", "J", and "P" through the right side panel of the left mounting and then up through the area between the right side panel and the structure of the left mounting. Feed cables "K" and "N" through both the right side panel and right side gusset entrance of the left mounting. In the left mounting remove the screw holding the cable clamp on the left side of the angle iron behind the terminal board, E-702, and mount the clamp in the corresponding tapped hole on the right side of the angle iron. Connect one end of the base mount to the transmitter group interstack cable "M" to the indicated terminals on E-702 in the left mounting. Run the free end of the cable through the cable clamp on the right side of the angle iron. (See figure 3-13.) Do not tighten this clamp at this time. Pass the free end of cable "M" through the right side gusset entrance and then up through the area between the right side panel and the mounting structure. Slide the two mountings into their approximate positions so that the two side panels are adjoining. Feed interstack cable "K" across the floor of the left-hand mounting, through the left side gusset entrance, and then up through the area between the left side panel and the mounting structure. Pass interstack cable "N" through the same clamp holding cable "M." Tighten the clamp, packing the inside of this clamp, if necessary to insure that the clamp fits tightly around cables "M" and "N". Using the Interconnecting Cabling Diagram, figure 3-32, as a guide, make the indicated connection of cable "N" on E-702 in the left mounting.

Each mounting is provided with two ground straps. Ground the mounting by securing the free end of each strap to a clean, unpainted portion of the foundation or ship's bulkhead. Thread the adjustable inserts in or out until the space between the two mountings is 3/32 inch. Then secure each mounting to the bottom shock mounts with the 5/8-11 x 1-inch long hex head cap screws and 5/8-inch lock washers provided in the installation kit (items 5 and 6 on figure 3-25). Using the 5/16-18 x

2-inch long hex head cap screws, 5/16-inch lock washers, and 5/16-inch nuts provided in the installation materials (items 9, 10, and 11 on figure 3-25), secure the front and rear of the two mountings together.

In the left mounting, lace all the conductors of all cables except the interstack and the coaxial cables entering the left mounting and pass them through the right side gusset entrance, and up through the area between the right side panel and the mounting structure. In the right mounting, lace all the conductors of all cables except the three-phase power cable (R-RT2), the interstack and the coaxial cables entering the right mounting, and pass them through the right side gusset entrance and up through the area between the right side panel and the mounting structure. The three-phase power cable (R-RT2) entering the right mounting should be fed through the left-hand cable slot on the top of the right mounting. Then replace and reconnect the two capacitors, C-701 and C-702, in each mounting.

Remove the five equipment drawers from each of the transmitter group cabinets, by first loosening the captive screws that secure the drawers to the cabinet, using the special wrench mounted on the low voltage power supply front panel. Starting with the top drawer, pull the drawer forward on the rails until a stop on the rail is engaged. Disconnect the connectors of the retractable cabling from the connectors on the drawer. The connector assembly of the retractable cabling has an angle which should be latched on the post that is located on the transmitter group cabinet front above the top drawer, which, in turn, keeps the retractable cabling in its extended position. To complete the removal of the drawer, remove the two machine screws, one on each inner rail, that act as retainers for the latch in case of failure of the latch spring. Depress the latch on each inner rail and pull the chassis forward to clear the projection on the front of the rail.

WARNING

The drawer is now free to be removed entirely from the cabinet. Personnel removing chassis should now be prepared to support the entire weight of the drawer.

Continue to pull the drawer forward until the inner slide disengages from the front rail roller, at which point the drawer will be completely free from the cabinet. Repeat the above process for each succeeding drawer. For all other drawers, the retractable cabling, after it is disengaged from the drawer, is returned to the rear of the cabinet.

Remove the high voltage power supply drawer from its cabinet in the same manner as described for the drawers in the transmitter group cabinet. Resting the front of the cabinet on the front of the right mounting, feed interstack cable "K" coming from the left side of the right mounting into the area of the high voltage power supply cabinet occupied by terminal board E-1404. Feed the three-phase power cable (R-RT2) through the left cable hole in the bottom of the high voltage power

supply cabinet. Feed interstack cables "H" and "J" coming from the right side of the right-hand mounting, through the area between the right side panel of the high voltage power supply cabinet and its structural members and into the cabinet through the right side entry. Feed interstack cables "L" and "P" and the incoming cables, coming from the right side of the right-hand mounting, through the area between the high voltage power supply cabinet right side panel and the cabinet structure, and out of the top of the cabinet. Lower the cabinet into place so that all aligning tabs are inside the side panels. Secure the cabinet to the mounting with the 1/2-13 x 1-inch long hex head cap screws and 1/2-inch lock washers (items 7 and 8 on figure 3-25) provided in the installation material box. Remove two adjustable inserts (item 14 on figure 3-25). Thread an insert into each of the tapped holes on the left side of the high voltage power supply cabinet.

Remove the high level radio modulator drawer from its cabinet in the same manner as described for the drawers in the transmitter group cabinet. Resting the front of the cabinet on the front of the left mounting, feed interstack cable "K", coming from the left side of the left mounting, through the area between the high level radio modulator cabinet left side panel and the cabinet structure and out of the top of the cabinet. Feed interstack cable "J", coming from the right side of the left mounting, through the area between the high level radio modulator cabinet and its structural members, and into the cabinet through the right side entry. Feed interstack cables "H", "M", and "P" and the incoming cables, coming from the right side of the left-hand mounting, through the area between the high level radio modulator cabinet right side panel and the cabinet structure, and out of the top of the cabinet. Lower the cabinet into place so that all the aligning tabs are inside the side panels. Secure the cabinet to the left-hand mounting with the 1/2-3 x 1-inch long hex head cap screws and 1/2-inch lock washers (items 7 and 8 on figure 3-25). Feed the high level radio modulator to the transmitter group interstack cable (cable "R") from the high level radio modulator cabinet, through the right side entry, up through the area between the cabinet right side panel and the cabinet structure and out of the cabinet, making sure the cable protrudes far enough to fan out to the transmitter group terminal boards. Lace cable "R" to the other cables passing up the right side of the high level radio modulator.

Secure the four sway mounts (item 18 of figure 3-25) to the bulkhead foundation. Remove the right side panel from the transmitter group cabinet that is to mount on the high voltage power supply cabinet by removing the 22 binding-head machine screws that mount each side panel to the cabinet frame. Remove the expendable base blocks from one of the transmitter group cabinets. Secure one eyebolt (item 12 on figure 3-25) into each of the tapped holes in the top of the transmitter group cabinet. Carefully hoist the cabinet into a position a few inches above the high voltage power supply cabinet.

Taking care to avoid damage to any of the aligning tabs, block the transmitter group cabinet in position. Two coaxial cables terminating in connectors P-609 and P-610 are located, loose, on the bottom of the transmitter group cabinet. Pull these cables, with their connectors, back through the right side entry and drop them down through the area between the right side panel and the cabinet structure, through the corresponding area in the right side of the high voltage power supply cabinet, through the same area in the mounting and into the mounting through the right side gusset entrance. Mate connectors P-609 and P-610 with the corresponding connectors that have been affixed to the incoming cables, using Interconnecting Cabling Diagram (figure 3-32) as a guide. Feed the cables coming out of the top of the right side of the high voltage power supply cabinet into the bottom of the transmitter group cabinet through the cable entry located at the bottom of the right side of the cabinet at the rear. These cables should pass through this entry behind the transmitter group cabinet wiring, which also enters the bottom of the cabinet at this point. Replace the right side panel. Lower the transmitter group cabinet into place on top of the high voltage power supply cabinet. Bolt the two units together with ten 1/2-13 x 1-inch long hex head cap screws and 1/2-inch lock washers (items 7 and 8 on figure 3-25), but do not tighten the bolts completely. Secure the transmitter group cabinet to the bulkhead sway mounts with the 3/8-16 x 1-inch long hex head cap screws and 3/8-inch lock washers (items 19 and 20 on figure 3-25), but do not tighten the screws completely. Thread leveling inserts (item 14 on figure 3-25) into all the tapped holes on the left side of the right transmitter group cabinet. With the exception of leveling inserts, install the second transmitter group in the same manner. The two top inserts on the right-hand transmitter group should be adjusted until the sides of the two transmitter group cabinets are parallel and, if possible, not over 3/32-inch apart. The adjustable inserts used in this equipment permit the two stacks to be joined together mechanically in spite of misalignments arising from manufacturing tolerances. Bolt the two transmitter group cabinets together at the top with two 5/16-inch cap screws, 5/16-inch lock washers, and 5/16-inch nuts (items 9, 10, and 11 on figure 3-25) and tighten. Tighten the cap screws holding the transmitter group cabinets to the bulkhead sway mounts. The remaining inserts in the transmitter group and modulator cabinets should be threaded out until they touch the side wall of the cabinets on the left. If the cap screws securing the booster cabinets to the mounting and the transmitter group are loose enough, a small amount of adjusting is possible by edging the cabinets toward or away from the center line as required. When the spacing between the two stacks is correct, tighten the cap screws holding the booster components to the mountings and the transmitter group cabinets to the booster. Then secure the two stacks together, as shown on section A-A of figure 3-25, with the remaining eight 5/16-inch cap screws, 5/16-inch lock washers, and 5/16-inch nuts

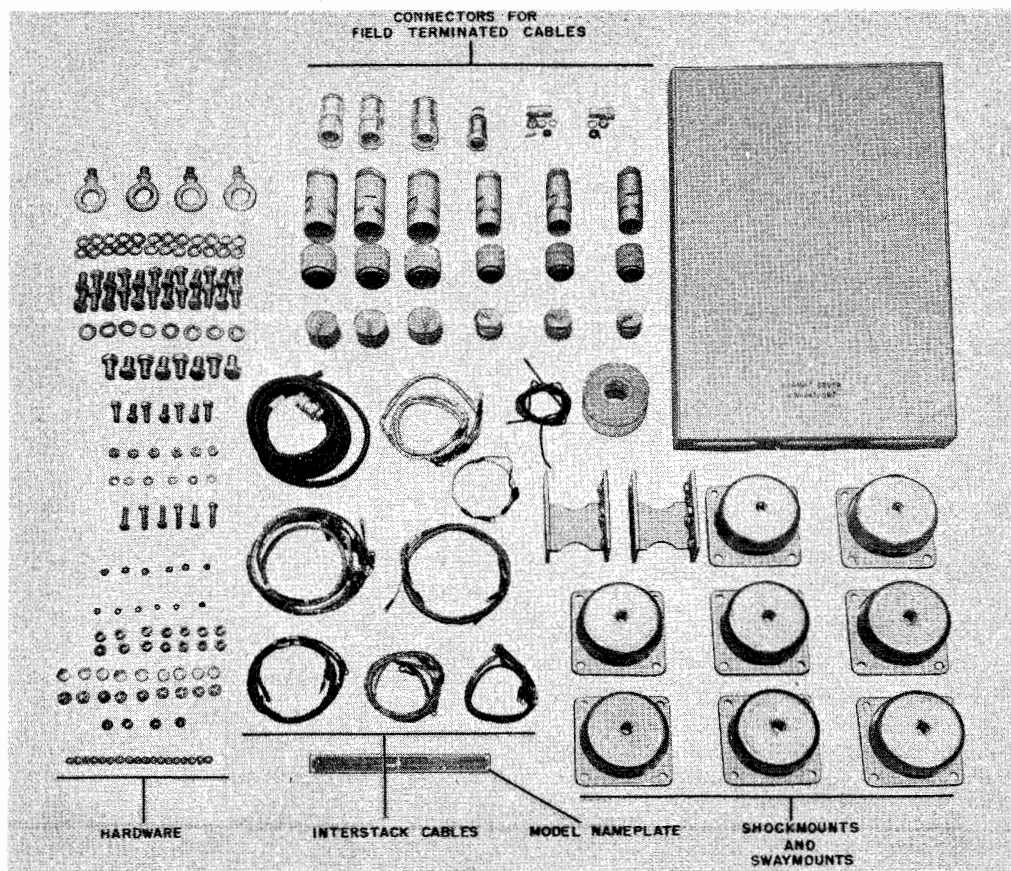

Figure 3-10. Installation Material, AN/SRT-15

(items 9, 10, and 11 on figure 3-25). Remove the four eyebolts from the top of each transmitter group cabinet, but do not replace the top covers until the wiring has been completed. Thread the remaining two leveling inserts (item 16 on figure 3-25) into the left side of the left mounting. Thread the remaining 12 leveling inserts into the left side of the left transmitter group and the left side of the high level radio modulator cabinet. Insert 14 plug buttons (item 17 on figure 3-25) in the leveling inserts. Insert 14 plug buttons (item 15 on figure 3-25) in the holes of the right side of the right transmitter group, high voltage power supply cabinet and mounting.

(4) TRANSMITTER COUPLER CU-402/SRT.—After a suitable location has been found according to paragraph 2a(2) of this section, the only procedure required to mount the Transmitter Coupler CU-402/SRT is to prepare four mounting holes on the bulkhead in accordance with the mounting centers as specified on the Outline Drawing, figure 3-27, and fasten the unit to the bulkhead with the required bolts.

b. ANTENNA TUNING EQUIPMENT.—Outline Drawings, figures 3-28 and 3-29, for the Antenna Coupler CU-372/SRT and Radio Frequency Tuner TN-229/SRT respectively, provide foundation drilling plans

and minimum clearance requirements for mounting these units. Generally it will be found easier to locate the shock mounts on the foundation with the units removed. However, in certain instances of close clearance, it may be found easier to mount the entire unit assembled. There is a soft copper grounding strap in the installation material for each unit. One end of each strap is first attached to the ground stud on the end of each unit. The other end of the strap is to be cleaned and secured to a clean, unpainted portion of the superstructure.

5. WIRING THE EQUIPMENT.

a. GENERAL.—The interstack cables used for the standard adjoining arrangements of the AN/SRT-15 and the AN/SRT-16 transmitter bays are prefabricated at the factory and supplied with the equipment. All other interconnecting cables must be fabricated by the installing technicians, using bulk Navy cables and connectors and accessories supplied with the equipment.

In wiring the various units of the set, the installing technicians should be certain that the following precautions are observed:

(1) The internal cables of the transmitter stacks must clear all high-voltage points and drawer pins.

(2) With the exception of shielded leads, all armor

on cables entering the transmitter stacks must be stripped back to the stuffing tubes.

(3) All coaxial cables must be as short as possible and run clear of all hot or abrasive structures.

(4) No sharp bends shall be made in a coaxial cable. The minimum bending radius of 2-1/2 inches for RG-54A/U must be observed.

(5) All wires must approach terminal boards directly, without undue looping.

If the procedure outlined in the assembly section has been followed, the transmitter group interconnecting cables have already been stripped of armor and sheath, laced together and fed into their respective cabinets. The interconnecting wiring diagrams and following text should be used as a guide in completing the wiring of the individual cabinets.

b. TRANSMITTER BAY.

(1) TRANSMITTER GROUP CABINETS.—The majority of the cables terminating in this unit are connected to the terminal board assembly on the floor of the cabinet. This assembly comprises seven terminal boards, E-601 through E-607, arranged in numerical order from front to rear on the cabinet floor. The entire assembly is covered by a metal plate designed to protect the connecting wires from abrasion or accidental contact. The last terminal board, E-608, is located on the lower left side of the cabinet frame to the left of E-607. All terminal boards are easily accessible if the two lowest drawers (medium voltage power supply and low voltage power supply) are removed from the cabinet.

Remove the metal plate covering the terminal boards, E-601 through E-607. In an AN/SRT-14 or AN/SRT-15 installation, all interstack cables terminating on the cabinet floor should run from the cable slot at the left rear of the cabinet floor, and then forward along the left side of the terminal board assembly, and branch off along the front of the terminal boards to which they are connected. The incoming cables run from the cable slot at the left rear of the cabinet floor forward along the left side of the terminal board assembly and branch off along the front of the terminal boards to which they are connected. In an AN/SRT-16 installation, both interstack and incoming cables that terminate on the cabinet floor enter through the cable entry at the rear right of the cabinet floor. These conductors should run across the floor of the cabinet, behind the terminal board, E-607, and then forward along the left side of the terminal board assembly and branch off along the front of the terminal boards to which they are connected. Using the applicable Interconnecting Cabling Diagram (figure 3-30, 3-31, or 3-32), sort out the conductors according to the terminals to which they connect. As sorting is done, a cross reference list, showing the insulation color code against the wire number designated on the Interconnecting Cabling Diagram for each conductor of each incoming cable, should be made. Trim the length and remove enough insulation from the end of each conductor to expose sufficient bare conductor for a secure connection and attach the terminal lugs (the pre-

fabricated interstack cables are completely assembled with terminal lugs and marker bands for each conductor). Replace the metal plate after all connections have been made to terminal boards E-601 through E-607.

The two connections to terminal board E-608 have been brought into the cabinet at the location of E-608. Remove the cover on E-608 to make the connection. If the prefabricated interstack cables are used, the shields on the individual conductors are terminated in ring terminals that should be grounded to the screw provided below the terminal board. If RG-54A/U cable is used, in place of the prefabricated interstack cable, remove the last three inches of jacket from the cable. Make a hole in the shielding at the point where it leaves the jacket by pushing the individual strand of the braid to each side. Taking care to avoid damage to the insulation, insert a small screwdriver between the shield and the insulated conductor and pull the insulated conductor out through the hole in the shield. Remove sufficient insulation from the end of the conductor and attach lugs to the conductor and to the shield and connect each as specified on the Interconnecting Cabling Diagram. Replace the cover on E-608 after the connections have been made. On an AN/SRT-14 there is no external connection to this terminal board.

The connections to the r-f output connectors, P-609 and P-610, should have been made at the time of assembly (paragraph 4a).

In an AN/SRT-14 transmitter bay installation, two jumpers are required: one on E-606 and the other on E-608. On E-606 place a jumper between terminals 76 and 77, using SRIR-1-1/2(7)-18 hook-up wire. On E-608 place a jumper between terminals 1 and 2, using SRHV-2-1/2(19)-16 high-voltage hook-up wire.

(2) MOUNTING—The connections in the mounting should have been made at the time of assembly (paragraph 4a).

(3) RADIO MODULATOR-POWER SUPPLY.—The terminal boards of the high voltage power supply section of the booster are all located on the floor of the cabinet, with the exception of the high-voltage terminal boards, which are on the rear left of the cabinet frame. The three terminal boards on the floor are numbered E-1401, E-1402, and E-1410, with the high-voltage terminal board numbered E-1404. The high level radio modulator cabinet contains three terminal boards. Of these, the first two terminal boards, E-1406 and E-1407, are located on the floor of the cabinet, arranged in numerical order from front to rear. The high-voltage terminal board, E-1408, is mounted on the rear left of the cabinet frame.

In the high voltage power supply cabinet the three-phase power cable enters the cabinet through the cable hole in the left rear of the cabinet; the interstack cables that terminate on terminal boards E-1401 and E-1402 enter through the cable entry at the rear right of the cabinet. The interstack cable to terminal board E-1404 enters the cabinet at the location of E-1404. Remove the plate covering the terminal boards on the cabinet floor

and the cover on E-1404. Run the three-phase power cable across the rear of the cabinet, and then down the right side of the cabinet, through the cable clamp, to E-1410. Tighten the clamp and prepare the conductors and connect in the same manner as described in paragraph 5b(1). Run the interstack cables terminating at E-1401 and E-1402 forward along the right side of the terminal boards branching off along the front of the terminal boards to which they connect. These cables are fully prepared and need only to be connected to the correct terminals according to the applicable Interconnecting Cabling Diagram. The connections made to E-1404 are made as described for E-608 in paragraph 5b(1). Replace the covers after connections are made.

In the high level radio modulator cabinet the interstack cables are wired in the same manner as prescribed for the high voltage power supply, with the interstack cables, terminating at terminal boards E-1406 and E-1407, entering through the cable entry at the rear right of the cabinet, and the interstack cables, terminating at E-1408, entering the cabinet at the location of E-1408.

(4) TRANSMITTER COUPLER.—There are three interconnecting cable assemblies required to interconnect the transmitter coupler with both the transmitter group and the antenna tuning equipment. (See the three Interconnecting Cabling Diagrams, figures 3-30, 3-31, and 3-32.) One assembly, terminating with P-3315, is supplied with the installation material. The end terminating in the transmitting group cabinet has already been connected (paragraph 5b). The r-f coaxial cable, interconnecting the transmitter coupler with the transmitter group, is made from RG-8/U bulk Navy cable. The transmitting group end of this cable has already been connected (paragraph 4a). An RG-21B/U connector, P-3314, which is found in the installation materials, is assembled to the other end according to the procedure shown on figure 3-12. The remaining interconnecting cable is prepared from RG-18/U bulk Navy cable. The end terminating at the transmitter coupler is assembled to a UG-167A/U connector, P-3308, found in the installation materials, according to the procedure detailed on figure 3-14. The wiring of the antenna tuning equipment (paragraph 5c) covers the connections to the other end of this cable. The interconnections to the transmitter coupler can now be made by mating the connectors with the appropriate receptacle on the transmitter coupler as follows:

- (a) Mate P-3315 with J-3303.
- (b) Mate P-3308 with J-3202.
- (c) Mate P-3314 with J-3201.

c. ANTENNA TUNING EQUIPMENT.—The interconnection of the two components of the antenna tuning equipment, Antenna Coupler CU-372/SRT and Radio Frequency Tuner TN-229/SRT, with each other, with the transmitter group, and with the antenna standoff are made by a set of cable assemblies made from connectors supplied with the installation material and bulk cable taken from Navy stores. Table 3-5 shows the con-

nectors and cable type for each assembly. The Interconnecting Cabling Diagrams (figure 3-30, 3-31, or 3-32) state the critical cable lengths involved. Assemble the UG-154/U connectors according to figure 3-15 and assemble the adapter (CBTL A-2011254) according to figure 3-16. For the multiconductor cable, follow both figure 3-33 and the applicable Interconnecting Cabling Diagram. The cables interconnecting to the transmitter group already have the transmitter group end connected (paragraph 5b(1)). Use the color code cross reference list prepared when these cables were connected to the transmitter group to insure that the connections to the multiconductor connectors will agree with the wire numbers as shown in the Interconnecting Cabling Diagram. When preparing an assembly where both ends of the cable terminate in multiconductor connectors, color code cross references should be prepared to insure that each conductor terminates on the same lettered contact on each end.

With regard to the interconnecting cables between the transmitter bay location and the antenna tuning equipment, assemblies should be prepared after the cables have been run. After all assemblies have been completed, mate the cable connectors to the correct receptacles on the antenna tuning equipment according to table 3-5.

d. REMOTE RADIOPHONE UNIT.—The Interconnecting Cabling Diagrams (figure 3-30, 3-31, or 3-32) show the interconnections between the transmitter group and the remote radiophone unit. The transmitter group end of these connections has been prepared (paragraph 5b(1)). The other end should be prepared with ring terminals for connections to the terminal board of the radiophone unit. Again, a color code cross reference to wire numbers will prove helpful in establishing the correct point-to-point connections. When a large number of equipments are installed, it may be necessary to connect the radiophone unit to a patch panel instead of running a direct line to the transmitter group.

6. MAIN TEST CABLE ASSEMBLY.

Although the rail and slide mechanisms, employed in the Transmitter Group OA-684/SRT and the Radio Modulator-Power Supply OA-685/SRT, permit the chassis of each major unit to be drawn out to give access to the rearmost part of the chassis, there will be circumstances where it will be more practical for purposes of maintenance to withdraw a chassis completely from a cabinet. For such situations a test cable must be used to interconnect the unit on a test bench to the cabinet in which it is normally connected, for purposes of supplying all of the normal voltages and signals required to energize the unit being tested.

This main test cable should be assembled at the time of installation of the equipment, prior to the initial operation, so that the cable will be available for use if the initial check and operation show that corrective maintenance will be required. All the connections, mounting, hardware, etc., required for the preparation of this cable are supplied packed in with the installation

TABLE 3-5. ANTENNA TUNING EQUIPMENT CONNECTOR ASSEMBLIES

ASSEMBLY DESIGNATION	MATES WITH	CONNECTOR TYPE	ACCESSORIES	CABLE USED WITH	CABLE TERMINATION AT OTHER END
P-3301	J-3502 ANT. COUP.	BENDIX 10-64632-8S	BENDIX 10-35952-321	MHFA-24	TRANS. GROUP E-603 through E-607
P-3302	J-3504 ANT. COUP.	BENDIX 10-64624-28S	BENDIX 10-35952-244	MSCA-19	TRANS. GROUP E-602, E-604, E-605, E-606
P-3303	J-3503 ANT. COUP.	BENDIX 10-64624-28P	BENDIX 10-35952-244	MSCA-19	P-3305
P-3304	J-3501 ANT. COUP.	BENDIX 10-64632-8P	BENDIX 10-35952-321	MHFA-24	P-3306
P-3305	J-302 R-F TUNER	BENDIX 10-64624-28S	BENDIX 10-35952-244	MSCA-19	P-3303
P-3306	J-301 R-F TUNER	BENDIX 10-64632-8S	BENDIX 10-35952-321	MHFA-24	P-3304
P-3307	J-3506 ANT. COUP.	UG-154/U		RG-18/U	P-3308
P-3308	J-3202 TRANS. COUP.	UG-167A/U		RG-18/U	P-3307
P-3309	J-3505 ANT. COUP.	UG-154/U		RG-18/U	P-3310
P-3310	J-303 R-F TUNER	UG-154/U		RG-18/U	P-3309
P-3311	W-3502 ANT. COUP.	CBTL A-2011254		RG-17/U 1st Extrusion	P-3312
P-3312	W-301 R-F TUNER	CBTL A-2011254		RG-17/U 1st Extrusion	P-3311

material. The cable wires required are to be supplied by the Navy at the installation site.

Upon opening the carton containing the cable components, a shipping list drawing (drawing No. NL-901 579-1) and a set of seven other drawings providing assembly information will be found as outlined in table 3-6.

The following assembly procedures have direct references to the above drawings and will contain only as much information as is required to supplement and coordinate the information found on the drawings.

a. PREPARATION OF CABLE.—There are 56 conductors required for the test cable. Drawing NL-901 061-1 is a complete specification for a manufactured cable and can be used as a guide. Paragraph 4.4 of this

specification lists the quantity, sizes, and color codes of the wires required. The specification states that the cable be eight feet long, which length is not critical.

Note

Substitute color coding may be used. However, a cross reference list will be required between the chosen color code and the one appearing in drawing NL-901061-1, as the wiring diagram and cable harness drawings are prepared based on the color code given in NL-901601-1.

Take cable harness drawing NL-901194-14 and divide sheet 1 into two parts by cutting vertically through the drawing where the cable is shown broken. Tack the two portions of this drawing on a board so that the distance

TABLE 3-6. MAIN TEST CABLE
ASSEMBLY DRAWINGS

DRAWING NO.	TITLE
NL-901061-1	Preliminary Specification for 56-conductor Cable
NL-901192-29	Main Test Cable Assembly (SRT)
NL-901193-14	Wiring Diagram — 56-conductor Test Cable
NL-901194-14	56-conductor Test Cable — Cable Harness
NL-95055-1	Cable Assembly Instructions for BNC Connectors
NL-900711-1	Cable Assembly Instruction — Type N Connectors
NL-983357-1	Specification for Grounding Shielded Wire
NL-983346-1	General Specification for Wiring Diagram and Cable Drawings

between the pins is about 22 inches shorter than the length cut for the wires. For instance, if the length of wire cut is nine feet, then the two portions of the drawing should be separated so that the dimensions between the location of the pins is 86 inches (disregard the 96-inch dimension shown on the drawing). This now constitutes a template for making the cable.

Using sheets 2 and 3 of NL-901194 as a guide, lay in the individual wires on the template. For instance, wire No. 1 starts at station #1 on the left side and runs to station #35 on the right side, the excess of length being cut off at station #35. At station #1, the symbol 6W appears, which denotes that there are six wires that begin at station #1 and the running list (sheets 2 and 3) show that these are wires Nos. 1, 3, 4, 6, 7, and 8. Wire #2 is a shielded wire, whose conductor portion starts at station #2 and terminates at station #36. In accordance with note 4 on sheet 1 the shield on this wire terminates at point "A" on the left side and point "N" on the right side. At point "A" a grounding lead is attached to the shield in accordance with drawing NL-983357-1, figure 1, using ferrules according to table A of the cable harness drawing NL-901194-14 sheet 1 (item numbers of ferrules referred to on table A are those items shown on NL-901194-14 sheet 4 that correspond to items 29 through 33 on the shipping list drawing (NL-901579-1)). This grounding lead (wire No. 2A) is then terminated at station #3. Run all remaining conductors and grounding leads in a similar manner as described above.

After all wires have been run, lace together the wires running between the pins. Prepare the ends of all the conductors except the three coaxial cables in accordance with notes 5, 7, and 8 of drawing NL-901194-14 sheet 1. Remove the cable from the harness and either wrap the portion that was between the pins with electrical insula-

ting tape or enclose this portion of the cable in a vinyl tubing of appropriate diameter (approximately 1 inch).

b. PREPARATION OF CONNECTOR ASSEMBLIES.—There are two connector assemblies to be prepared for connection to either end of the cable. Main Test Cable Assembly (SRT) drawing NL-901192-29 shows the over-all assembly of the cable and the two connector assemblies. The various individual items going to make up the assemblies are identified on their containers by the item numbers appearing on the shipping list drawing NL-901579-1. Table 3-7 is a cross reference list between item numbers on the shipping list, NL-901579-1, and item numbers on the assembly drawing, NL-901192-29.

In the assembly procedure that follows, item numbers referred to are those on the assembly drawing, NL-901192-29, unless otherwise noted.

First assemble the box connector (item 10) and the washer (item 29) to the plate (item 3), and thread the cable clamp (item 9) on the box connector. Assemble the three Amphenol Blue Ribbon receptacles (item 14) to the plate with the appropriate hardware.

Note

To mount the end Amphenol receptacle, use tapped spacer (item 7) instead of nut (item 32).

Mount terminal plate (item 11) and tapped spacer (item 34) to the plate. Mount the insulator (item 5) to the cover assembly (item 4), but do not mount the cover assembly to the plate at this time.

Assemble the other box connector (item 10) and washer (item 29) to the box (item 1) and thread the cable clamp (item 9) on the box connector. Mount the spring (item 6) to the box. Assemble the three Amphenol Blue Ribbon plugs (item 13) to the box. Assemble the two chassis connectors (item 15) and the two jack assemblies (item 16) to the box. Mount the terminal plate (item 11) and tapped spacer (item 38) to the box.

c. WIRING AND FINAL ASSEMBLY.—The prepared cable and the two connector assemblies are ready to be united into the final test cable assembly.

Take the end of the cable that has the seven wires (including three coaxial leads) that extend beyond the other wires and feed this end through the cable clamp and box connector mounted in the plate (item 3). Pass the cable through the box connector until the covering on the cable protrudes 1/4 inch beyond the face of the box connector, and then tighten the cable clamp. Feed the seven wires that extend beyond the others through the cable clamp (item 33), and then mount the clamp on the plate. Take lengths of black fiberglass sleeving (item 35 on the shipping list NL-901579-1) and cut into lengths of 1/2 inch. Slip a piece of sleeving over the end of each wire, except the seven long wires, and push the sleeving back on each wire so that the tinned end of each wire is clear of the sleeving. Using the wiring diagram,

**TABLE 3-7. MAIN TEST CABLE ASSEMBLY
CROSS REFERENCE LIST**

ITEM NO. ON NL-901192-29	ITEM NO. ON NL-901579-1	DESCRIPTION
1	8	Box (Marking)
2	9	Cover
3	10	Plate (Marking)
4	11	Cover Assembly
5	12	Insulator
6	13	Spring
7	14	Spacer
9	16	Cable Clamp
10	17	Box Connector
11	18	Terminal Plate
13	19	Plug-Amphenol Blue Rib- bon Connector
14	20	Receptacle-Amphenol Blue Ribbon Connector
15	21	Chassis Connector
16	15	Jack Assembly
19	43	Screw — No. 4-40 x 5/16 lg
20	44	Screw — No. 4-40 x 1/4 lg
21	45	Screw — No. 4-40 x 3/8 lg
22	46	Lock washer — No. 4 split
23	47	Nut — No. 4-40 hex
24	48	Screw — No. 6-32 x 5/16 lg
25	49	Lock washer — No. 6 split
26	50	Nut — No. 6-32 hex
27	51	Washer — No. 4 flat
29	22	Washer
30	52	Screw — No. 3-56 NF-2 x 1/4 lg
31	53	Lock washer — No. 3 split
32	54	Nut — No. 4-40 hex
33	55	Cable Clamp
34	56	Tapped spacer, 1/4 x 5/8 lg, 6-32 tap
35	57	Tapped spacer, 1/4 x 3/4 lg, 6-32 tap
37	28	Connector, Plug
38	27	Connector, Panel Jack
39	26	Connector, Plug, Right Angle
40	25	Connector, Panel Jack
41	24	Cap, Plate
42	23	Cap, Plate

NL-901193-14, as a guide, first cut and mount the two terminal straps (item 34 on the shipping list NL-901579-1), and then make all electrical connections on the plate end of the cable. P-3610 and P-3611 (item 41) and P-3612 and P-3613 (item 42) are plate caps. After all connections have been made, push the lengths of sleeving down to insulate the connections. Attach marker bands as per the wiring diagram, NL-901193-14. Mount the cover assembly (item 4) to the plate (item 3).

Take the other end of the cable and feed it through the cable clamp and box connector mounted on the box (item 1). Pass the cable through the box connector until the covering on the cable protrudes 1/4 inch beyond the face of the box connector and then tighten the cable clamp. Slip a piece of sleeving over the end of each wire terminating on the Amphenol Blue Ribbon plugs. Using the wiring diagram as guide, first cut and mount the two terminal straps, and then make all electrical connections on the box end of the cable. After connections to the Amphenol Blue Ribbon plugs have been made push the lengths of sleeving down to insulate the connections. When wiring and assembling the two panel jack connectors (item 38) to the two small coaxial cables, a voltmeter or buzzer check should be made to the connectors at the other end of these cables to determine which of the connectors is J-3605 and which is J-3606 (J-3605 is connected to coaxial cable that has P-3608 at its other end and J-3606 is connected to coaxial cable that has P-3607 at its other end). Mount the three panel jack connectors, J-3605, J-3606, and J-3607, to the box. Mount the cover (item 2) to the box.

7. INITIAL ADJUSTMENTS.

a. GENERAL.—After the mechanical installation has been completed and all cables properly installed and connected, a series of initial checks and adjustments should be made when energizing the equipment for the first time. Although the equipment may have been previously calibrated and checked, the procedure below will reduce difficulties arising from handling in transit, installation variations, or replacement of critical vacuum tubes. The procedure includes power input adjustments, installation of tubes and fuses, a complete visual inspection, insertion of components, and trial tuning, in the order mentioned.

b. POWER INPUT ADJUSTMENTS.—The transmitter group components of the AN/SRT-14, 15 and 16 are designed for primary power of 110 volts, 60 cycles, single phase only. However, the booster components of an AN/SRT-15 and 16 may be operated from a primary power source of either 220 volts or 440 volts, 60 cycles, three phase. The equipment is normally shipped with all booster links set for 440-volt operation. Using figure 3-17 as a guide, set these link connections on E-1603 (high level radio modulator) and on E-1503, E-1504, and T-1504 (high voltage power supply), according to the primary power being used. The antenna tuning equipment receives its primary power from the transmitter group, which is 110 volts, 60 cycles, single

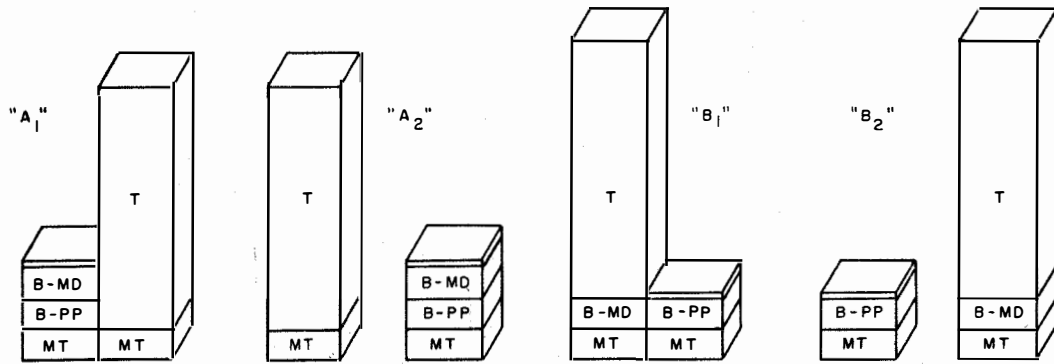

AN/SRT-15 TRANSMITTER BAYS *

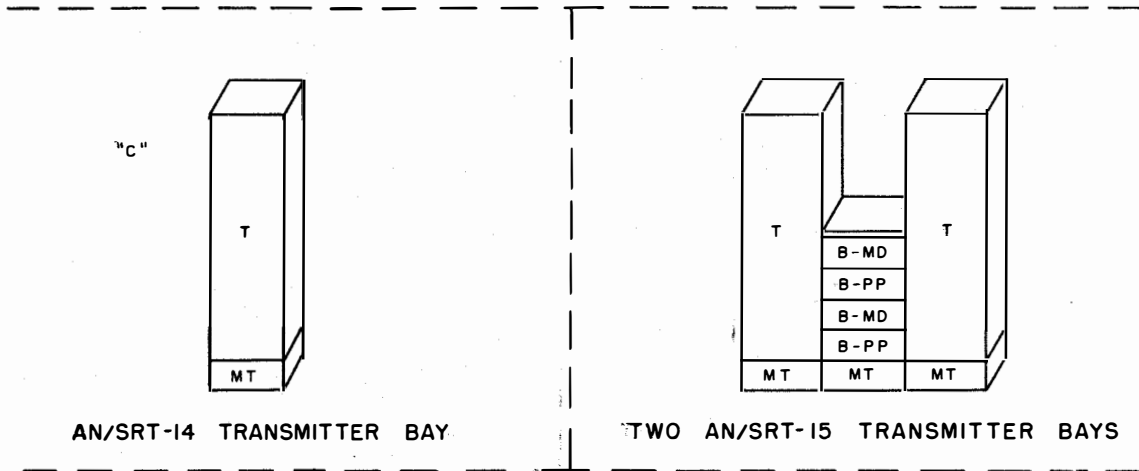

AN/SRT-14 TRANSMITTER BAY

TWO AN/SRT-15 TRANSMITTER BAYS

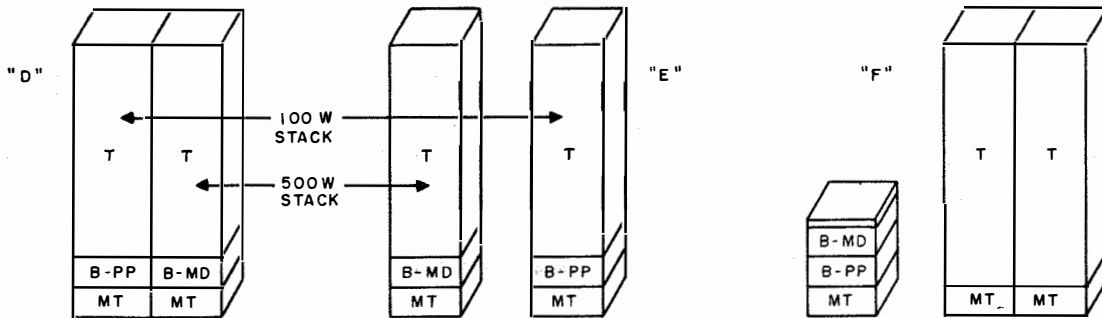

AN/SRT-16 TRANSMITTER BAYS *

MT = MT-1423/SRT

T = OA-684/SRT

B = OA-685/SRT (RADIO MODULATOR-POWER SUPPLY)

MD = MD-230/SRT

PP = 1096/SRT

* IN AN/SRT-15 AND 16 ARRANGEMENTS, POSITIONS OF RIGHT AND LEFT-HAND STACKS MAY BE INTERCHANGED.

Figure 3-11. Typical Transmitter Bay Arrangements

phase. Figures 3-34, 3-35, and 3-36 are the Primary Power Distribution Diagrams for all components of the AN/SRT-14, 15 and 16.

c. CHECKING INDIVIDUAL COMPONENTS.—The tubes for the transmitter bay are normally shipped installed in place in the various major units. Whenever possible, check each tube with a tube tester, then replace each tube in its socket, replacing any that may have been found to be defective. Consult Section 5 of this instruction book for the exact location of each tube. Special care should be taken in installing V-1304, type 4-400A power amplifier tube, in the radio frequency amplifier. Refer to paragraph 3c(2) of Section 5 for the correct handling procedure for V-1304.

In addition to V-1304, the two tubes in the high level radio modulator, V-1601 and V-1602, are packed separately. To install these tubes, first remove the two tube clamps (see figure 3-18) by loosening the two #10-32 binding-head machine screws mounting each clamp to the right side panel of the high level radio modulator. Insert the tubes into the two tube sockets, XV-1601 and XV-1602. Replace the two tube clamps and tighten the #10-32 screws. Connect the lead coming through the front grommet to V-1601 by placing the clip on the end of the lead on the plate cap of V-1601. In a similar manner, connect the lead coming through the rear grommet to V-1602.

Using table 5-6 as a guide, check and replace all fuses in their proper places. The fuses normally supplied for the high voltage power supply in an AN-/SRT-15 or 16 (F-1501 through F-1505) are those required for operation with 440-volt, three-phase primary power. If the primary power to be used is 220 volts, three phase, fuses F-1506 through F-1510 (6.25 amp each) must be drawn from Navy stocks and installed in place of F-1501 through F-1505.

Make a complete visual check of all aspects of each drawer of the transmitter bay. Check carefully for broken parts, loose wires, bent or damaged contacts, loose connectors, or any similar damage that may have occurred either in transit or in the process of installation.

After the visual check is completed, return all units of the Transmitter Group OA-684/SRT to the transmitter group cabinet, mating the connectors of the cabinet wiring to the corresponding connectors on the units. In a similar manner, return units of Radio Modulator-Power Supply OA-685/SRT (booster) (AN/SRT-15 and 16 only) to their respective cabinets.

CAUTION

When replacing the units in the cabinets, replace the retaining screws in the side rails.

d. TRIAL OPERATION.

(1) TRANSMITTER BAY.—Before energizing the transmitter bay for the first time, the r-f connection to the Transmitter Coupler CU-402/SRT should be broken and an external 50-ohm characteristic impedance, 600-watt dummy load, DA-91/U or equivalent, should be

substituted as a load to the radio frequency amplifier output. This is accomplished by disconnecting P-3314 on the RG-8/U cable from J-3201 on the transmitter coupler and coupling the dummy load to P-3314.

Note

The following trial operation procedures will designate the indications to note when the equipment is functioning properly. If, at any step in the operation, the proper indication is not found, reference to Section 7 of the instruction book should be made for correction of trouble.

After primary power has been applied to the equipment, the first indication of normal operation is that the three HEATER ON indicators on the radio frequency oscillator should come on, indicating that heaters in the three critical oscillator circuits in the radio frequency oscillator are energized. Allow a minimum of one hour after the heaters are first energized before the first step in the trial operation takes place to allow these critical circuits to reach the ambient temperature at which they are designed to work.

(a) 100-WATT OPERATION.—The transmitter group may now be energized. Throw the low voltage power supply EMERGENCY SWITCH (⊕) to the ON position. Set STANDBY-OPERATE switch (Ⓟ) in the STANDBY position. Depress the START push button of the MAIN POWER switch (Ⓡ). Listen for the sound of the blower in the radio frequency amplifier. The MAIN POWER indicator light on the low voltage power supply and 250 V.P.S. on the low level radio modulator should be lit at this time. The low voltage power supply has an approximate 25- to 30-second time delay, after which the TIME DELAY, the +250 V and -220 V indicator lights on the low voltage power supply and the 100 W-READY indicator on the radio frequency amplifier should come on. Listen for the blower motors in the mounting at this time.

Open the door on the radio frequency oscillator covering the nine frequency selection knobs. Set the knobs for a frequency of 0.3 mc according to instructions on the panel under the tuning knobs. Set the BAND-SWITCH (Ⓢ) to the proper band setting. Set the TUNE IPA control (Ⓟ), the TUNE PA control (Ⓡ), and the EXCITATION (Ⓢ) at their maximum clockwise setting. Place STANDBY-OPERATE switch (Ⓟ) in OPERATE and set the SERVICE SELECTOR (Ⓡ) on the low level radio modulator to the HAND position. Set LOCAL-REM switch (Ⓢ) on the low level radio modulator at LOCAL. The following indicators should light at this time: 500 V PRI, 500 V OUTPUT and 1300 V OUTPUT on the medium voltage power supply; +300 V on the low voltage power supply and the 100 W-ON on the radio frequency amplifier. Throw the TEST KEY (Ⓡ) on the low level radio modulator to its locking position. With the VOLTMETER-METER SELECTOR (Ⓡ) on the radio frequency amplifier in the RF IN position, the VOLTMETER should read a minimum of 2 volts. If the read-

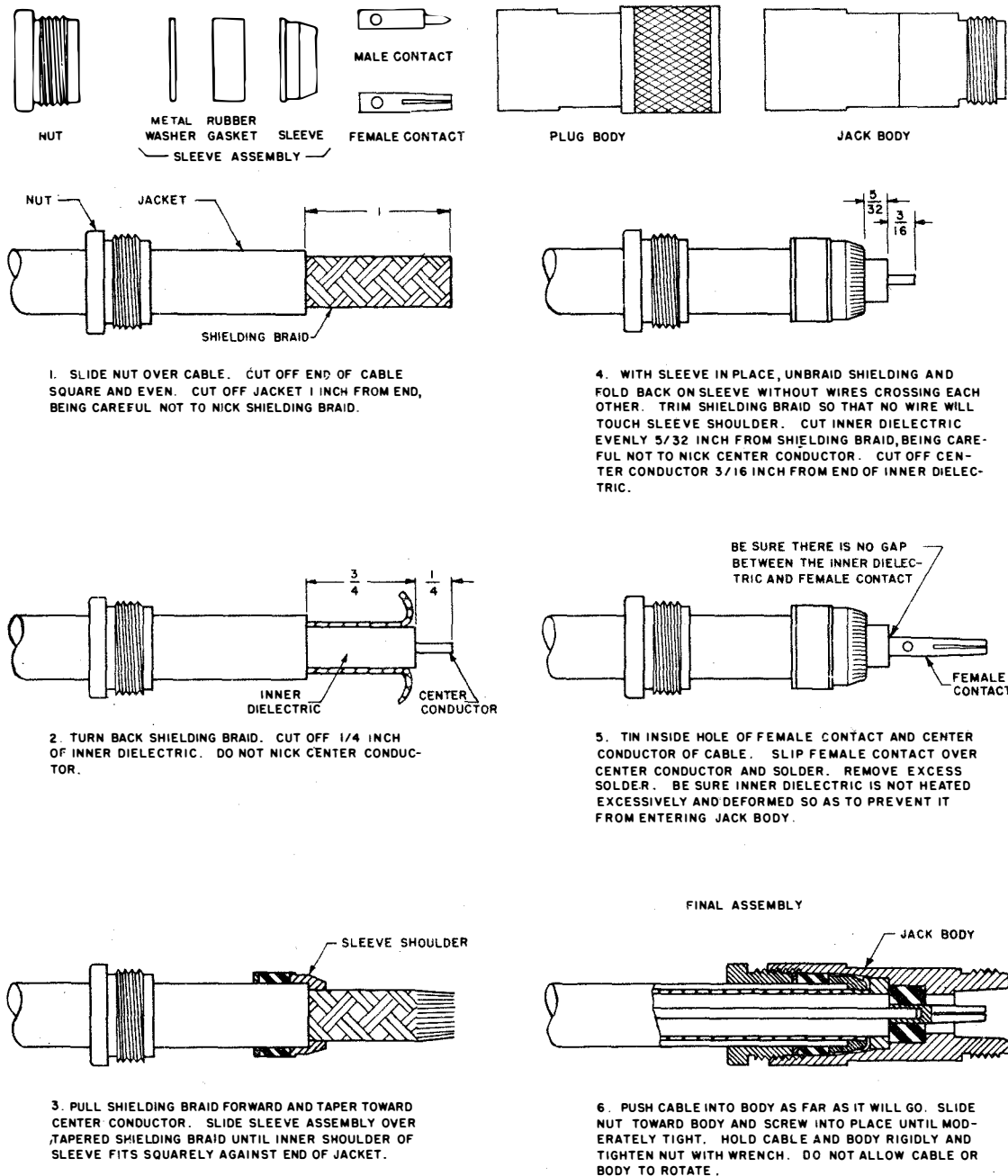

Figure 3-12. Assembly of UG-21B/U or UG-23B/U Connector on RG-8/U Coaxial Cable

3 Section

Paragraph 7 d (1) (a)

NAVSHIPS 92121(A)

INSTALLATION

AN/SRT-14, 14A, 15, 15A, 16, 16A

ing exceeds 5 volts, adjust the EXCITATION control Ⓣ to reduce the reading to 5 volts. Set the PA-METER SELECTOR Ⓜ to I_{c1} position and tune the TUNE IPA control Ⓟ counterclockwise until a peak on the PA CURRENT meter is reached. Continue to tune counterclockwise to see if a second peak is recorded on the meter. If there is a second peak set the control Ⓟ at this point but if there is no second peak, return the control Ⓟ to the position of the first peak. Regulate

the TUNE PA control Ⓣ in the same manner, using the ANT CURRENT meter as an indicator of tuning peaks.

This completes a trial operation at the 100-watt level. However, for a complete test of the transmitter group, a frequency in each of the other five tuning bands should be set up and the equipment returned to each (for instance, 1 mc, 6 mc, 10 mc, 18 mc, and 26 mc).

AN/SRT-15

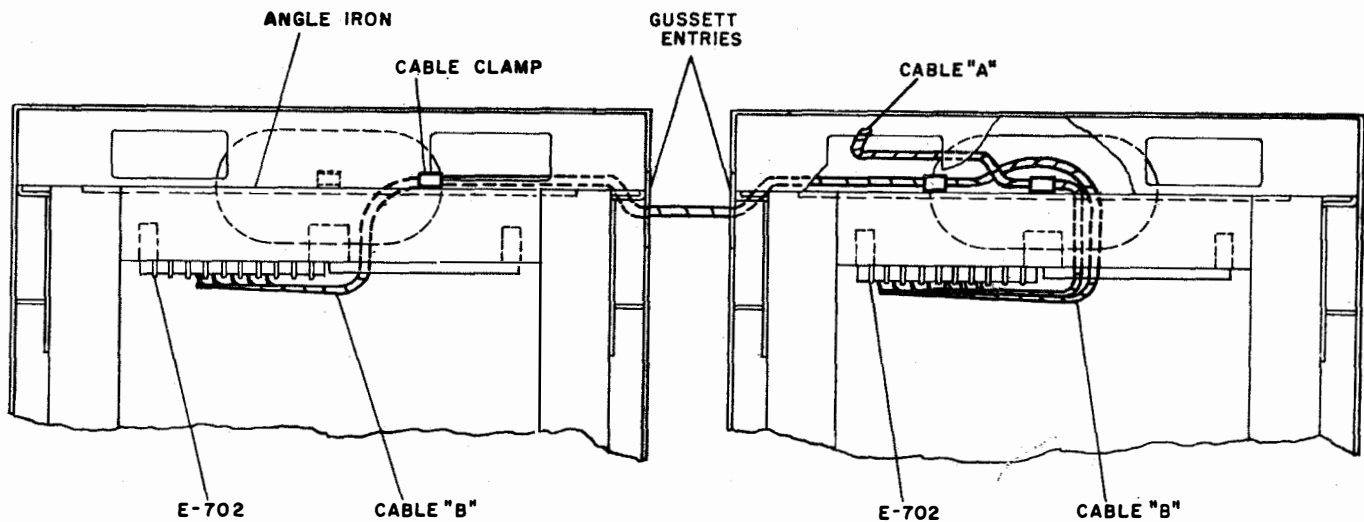

AN/SRT-16

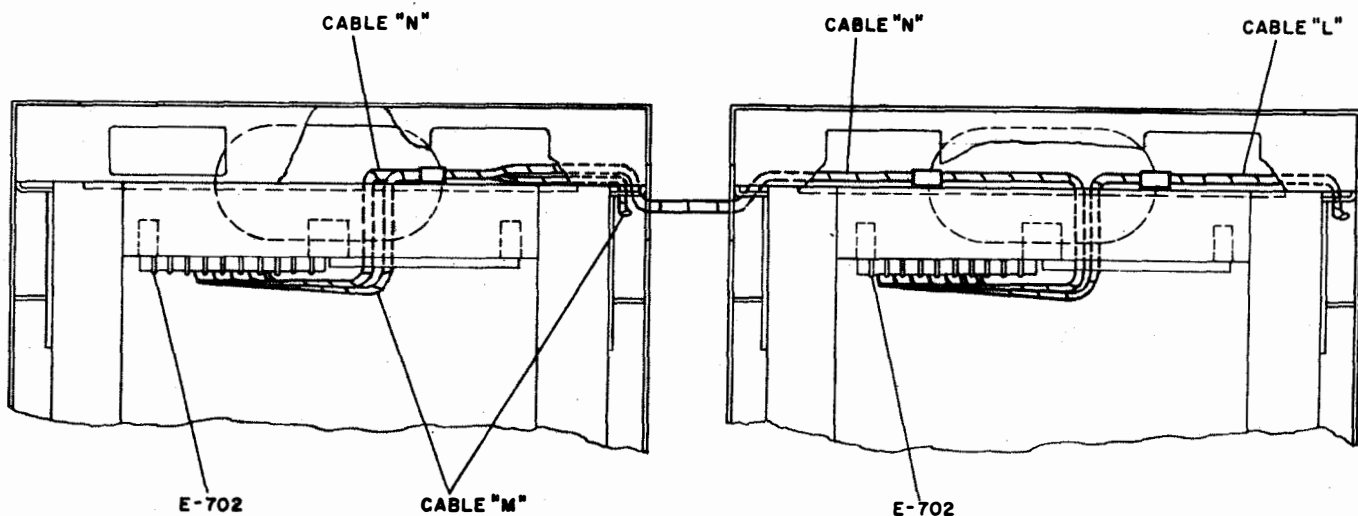

Figure 3-13. Installing E-702 Cables

Note

The highest frequency (26 mc) is obtained by setting the knobs to 25.9999910, with the 10 ~ knob Ⓢ set to the 10 position.

After the 6-mc tuning has been completed, the readings on all positions of the VOLTMETER, IPA CURRENT, PA CURRENT, and ANT CURRENT meters should be checked against the list of typical readings given in the 100-watt column of table 3-8.

TABLE 3-8. TYPICAL METER READINGS AT 6 MC, HAND, KEY DOWN

METER POSITION		100 WATTS	500 WATTS
ANT CURRENT		1.5	3.5
PA	Ic1	20 ma	12 ma
	Ic2	54 ma	16 ma
	Ik	0.2 a	0.2 a
IPA	Ic1	1.0 ma	1.0 ma
	Ic2	7.5 ma	9.0 ma
	Ik	60 ma	60 ma
VOLT-METER	RF IN	2.0 V*	2.0 V*
	BIAS	200 V	200 V
	LV	260 V	280 V
	MV	430 V	470 V
	PA Ec2	220 V	400 V
	PA Eb	1100 V	2800 V

*Depends upon the setting of the EXCITATION control Ⓣ.

If any difficulty is encountered in tuning to any of the above trial frequencies, first check the radio frequency oscillator drawer. This unit contains a number of tubes that are critical. If any of these tubes have been replaced in the tube testing procedure (paragraph 5c), it may be necessary to readjust the associated circuits according to the procedures given in table 3-9. If adjustments are required, the tuning procedures should be repeated for the transmitter group.

TABLE 3-9. CRITICAL RADIO FREQUENCY OSCILLATOR ADJUSTMENTS

REPLACED COMPONENTS	REQUIRED ADJUSTMENT PROCEDURES
UNIT 1 V-2001 (5654) Y-2001 (XTAL)	With the transmitter in "stand-by", allow crystal ovens to cycle for at least one hour. Tune a receiver (type RBB or equivalent) to 2.5 mc with BFO turned off. Connect the leg of a type "T" BNC connector to the 100 KC X-TAL receptacle on the RFO front panel.

REPLACED COMPONENTS	REQUIRED ADJUSTMENT PROCEDURES
UNIT 1 V-2001 (5654) Y2001 (XTAL) (cont'd)	Connect a coaxial cable to one arm of the "T" connector and terminate the other end of this cable at the receiver antenna input. Connect a receiving antenna, with a variable attenuator in series, to the other arm of the "T" connector. Adjust the attenuator so that the signal from WWV is at the same level as the 25th harmonic of unit 1 output. Adjust L-2001 on unit 1 for a zero beat indication. This indication should be observed aurally through the receiver speaker and visually by the indication on the OUTPUT meter of the receiver. The indicator on the OUTPUT meter will oscillate about the null; the frequency of this oscillation is the beat frequency. At high beat frequencies the indicator cannot respond and will remain at the null position. As the zero beat is approached, the indicator on the OUTPUT meter will start to oscillate rapidly. Then as tuning towards the zero beat is continued, the oscillation slows down until the zero beat is reached, at which point the indicator rests at the null position. Note Perform the above adjustment only when WWV is not modulating.
UNIT 3 V-2501 (6AK6)	Check the interpolation oscillator, operating at 100 kc, against the crystal oscillator as follows: Set KC knob Ⓢ, the 100 knob Ⓣ, and the 10 knob Ⓢ at 9, 9, and 10 respectively. Energize the equipment. Set the ZERO ADJ. control Ⓣ to the INT. OSC. position and, with a screwdriver, adjust the INT. OSC. ZERO ADJ. control, located on the same panel as the frequency selection knobs, so that the shadow angle on the ZERO BEAT INDICATOR reaches zero beat.
UNIT 6 V-2203 (5725) V-2204 (5654) V-2205 (6AK6)	Adjust C-2219 as follows: Place 10 KC knob Ⓣ at 9. Connect 10 KC STEP oscilloscope test jack on the radio frequency oscillator to horizontal input of an oscilloscope OS-8/U (or equivalent). Connect the 100 KC X-TAL test jack to the vertical input of the oscilloscope. Rotate C-2219 clockwise until the pattern on the oscilloscope drops out of synchronization. Rotate C-2219 counterclockwise until the pattern just locks in, and mark this spot on the chassis. Continue to rotate C-2219 counterclockwise until pattern again drops out of synchronization. Then rotate C-2219 clockwise until pattern just locks in again and mark this point on the chassis. Finally, set C-2219 midway between the two marks.

TABLE 3-9. CRITICAL RADIO FREQUENCY OSCILLATOR ADJUSTMENTS (Cont'd)

REPLACED COMPONENTS	REQUIRED ADJUSTMENT PROCEDURES
V-2202 (12AU7)	Adjust R-2210 as follows: Connect 10 KC oscilloscope test jack on the radio frequency oscillator to the vertical input of an oscilloscope OS-8/U (or equivalent.) Connect the 100 KC X-TAL test jack to the horizontal input of the oscilloscope. Adjust R-2210 to obtain a 10-to-1 pattern on the scope. Slowly turn R-2210 counterclockwise until pattern drops out of lock. Mark this point on the chassis. Turn R-2210 clockwise until the pattern locks in again. Continue turning clockwise until the pattern drops out of lock again. Turn R-2210 counterclockwise until pattern again locks in. Mark this point on the chassis. Set R-2210 midway between the two marks.
UNIT 8 V-2330 (5725) V-2331 (5725)	Adjust C-2405 and C-2406 as follows: Turn 100 KC control Ⓜ to 9. Connect VTVM, such as a ME-25A/U, to J-2330 on unit 8. Adjust C-2405 and C-2406 for maximum meter reading.
V-2327 (5725) V-2328 (5654) V-2329 (6AK6)	Adjust C-2339, located on the top of unit 8, as follows: Set the 100 KC control Ⓜ to 9. Connect the 100 KC STEP oscilloscope test jack to the horizontal input of an oscilloscope OS-8/U (or equivalent) and connect the 100 KC X-TAL test jack to the vertical input of this oscilloscope. A 25-to-1 pattern should appear. Adjust C-2339 in the same manner as described for C-2219 in unit 6.

An adjustment in the low level radio modulator may be affected by a tube replacement. If it is required to replace the keying multivibrator tube V-1017, then the setting of the ZERO ADJ control, R-1096, should be checked. This is a screwdriver adjustment located behind the UNIT ADJUSTMENTS door on the front panel. First, pull out the low level radio modulator chassis until the rail stop is reached. "Cheat" the interlock S-1104 located on the outside of the chassis left side panel by pushing in the button on the switch. Locate and remove tube V-1018. With a test meter, ME-25/U or equivalent, set at the +100-volt d-c range, measure between pin 1 on tube socket XV-1018 and ground. With the equipment energized and the TEST KEY Ⓣ operated, adjust the ZERO ADJ control, R-1096, to obtain a reading of +25 volts on the meter. Restore the TEST KEY Ⓣ to its normal off position and change the test meter selector from plus to minus; the meter should now read -30 volts \pm 5 volts.

(b) 500-WATT OPERATION.—After the 100-watt trial operation is complete on an AN/SRT-15 or

16, the 500-watt trial should be made. With equipment energized at the 100-watt level, tune to a frequency of 6 mc. After tuning is completed, return the STANDBY-OPERATE switch Ⓟ to the STANDBY position and return TEST KEY Ⓣ to OFF position.

Throw BOOSTER EMERGENCY switch Ⓢ to the ON position. After an approximate 30-second time delay, the time delay indicator should come on. Depress the PUSH FOR 500W push button ⓔ on the radio frequency amplifier. The 500 W READY indicator should come on. With the SERVICE SELECTOR Ⓤ on the low level radio modulator in the HAND position, place the STANDBY-OPERATE switch Ⓟ in OPERATE. The ϕ -1, ϕ -2, and ϕ -3 H.V. PRIMARY indicator on the high voltage power supply, the 3000 v and 350 v SCREEN indicator on the high level radio modulator and the 500 W-ON indicator on the radio frequency amplifier should come on at this time. Throw TEST KEY Ⓣ to KEY ON position. Check meter readings against those shown in table 3-8 under the 500-watt column. If the equipment installed is an AN/SRT-16, the 100-watt trial tuning should be repeated for the second transmitter group.

(c) TRANSMITTER COUPLER CU-402/SRT.—A trial of the Transmitter Coupler CU-402/SRT (load adjusting unit) is next in sequence. For the 100-watt and 500-watt trials, the r-f connection from the transmitter bay to the load adjusting unit was broken and the dummy load inserted. Now disconnect the dummy load from P-3314 on the RG-8/U interconnecting cable and reconnect P-3314 to J-3201 on the load adjusting unit. Disconnect the r-f connector, P-3308, on the RG-18/U interconnecting cable to the antenna tuning equipment from the receptacle J-3202 on the load adjusting unit, and connect the dummy load to J-3202.

Set the INPUT TAP Ⓥ on the load adjusting unit to the 4 position and then energize the transmitter bay as described for the 100-watt trial operation at a frequency of 6 mc (paragraph 7d(1)(a)). Adjusting the OUTPUT TAP Ⓦ at its various settings should cause different readings on the r-f ammeter. The optimum setting of both Ⓥ and Ⓦ should give a reading of approximately 1.5 amp.

(d) REMOTE CONTROL.—If the equipment operates correctly to this point, operation of the remote radiophone unit should be checked. De-energize the equipment by depressing the STOP button on the low voltage power supply. Restore the TEST KEY Ⓣ on the low level radio modulator to its center off position. Set the LOCAL-REM ⓧ switch on the low level radio modulator to REM. Depress the START button on the remote radiophone unit. The POWER indicator on the remote unit should come on together with the indicator on the transmitter group that would come on in the local operation when the START button on the low voltage power supply is depressed (paragraph 7d(1)(a)). With STANDBY-OPERATE switch Ⓟ on the low voltage power supply in OPERATE and the

SERVICE SELECTOR $\text{\textcircled{U}}$ on the low level radio modulator in HAND, patch transmitter to L.O.P. position. Depressing the key should produce the same results at the transmitter bay as were obtained when the TEST KEY $\text{\textcircled{T}}$ was operated in the local trial operation (paragraph 7d(1)(a)). Place the SERVICE SELECTOR $\text{\textcircled{U}}$ on the low level radio modulator in the PHONE position. Insert a phone in the phone jack on the radiophone and depress the press-to-talk switch. This should cause the CARRIER ON indicator on the radiophone to come on and should also energize a carrier at the transmitter bay. Depress the STOP button on the ra-

diophone unit. This should extinguish the POWER indicator and de-energize the transmitter bay.

Place the SERVICE SELECTOR $\text{\textcircled{U}}$ on the low level radio modulator in FSK position. Patch transmitter to TELETYPE position. Depress the START button on the control box at the TELETYPE position. Adjust transmitter for FSK-TT operation; see paragraph 4c. Place key in transmit, on the control box at the TELETYPE position. This should cause the carrier indicator to come on at the transmitter bay. Observe for correct frequency shift operation. Depress the STOP button on the control box at the TELETYPE position. This

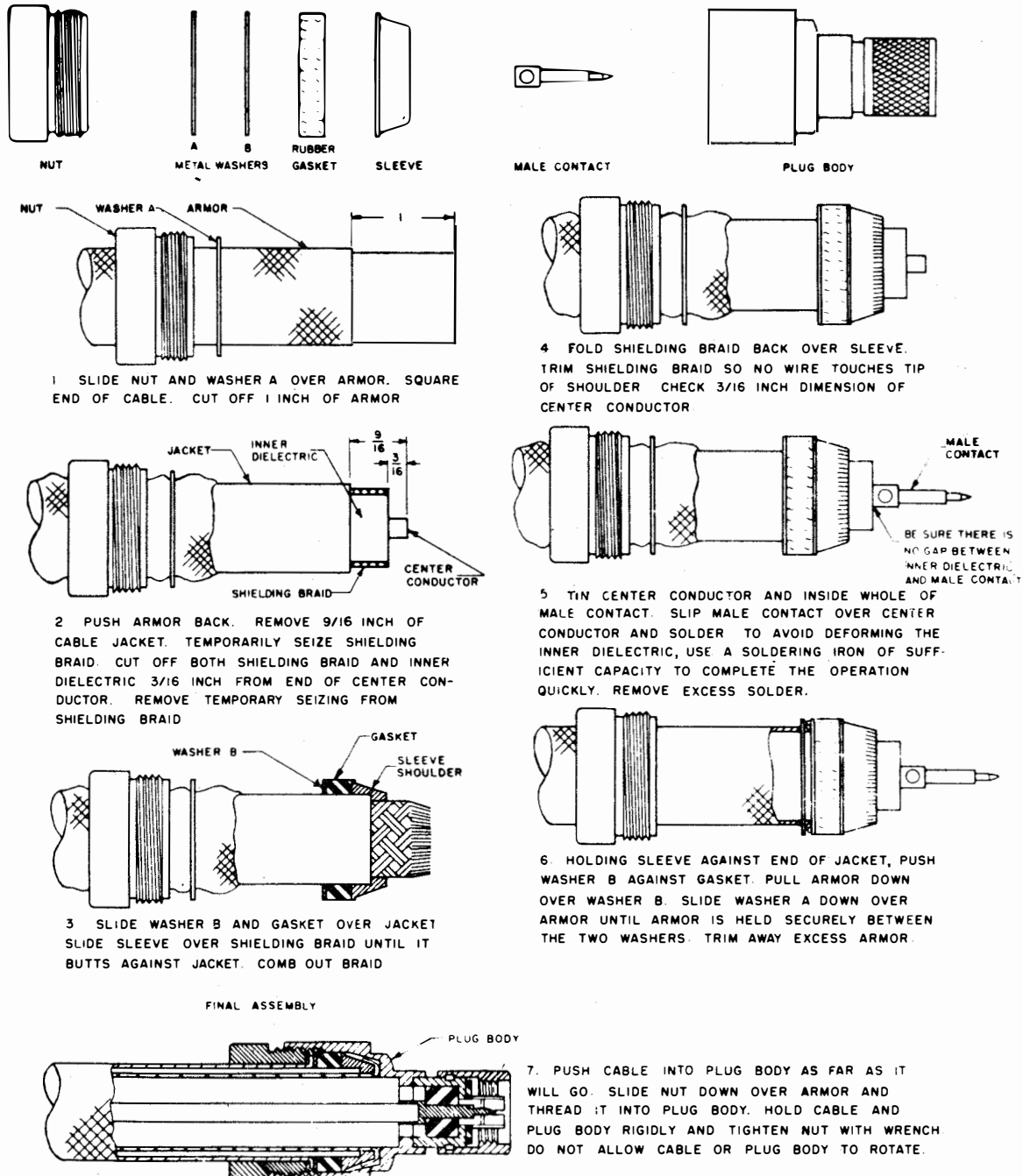

Figure 3-14. Assembly of UG-167A/U Connector on RG-18/U Coaxial Cable

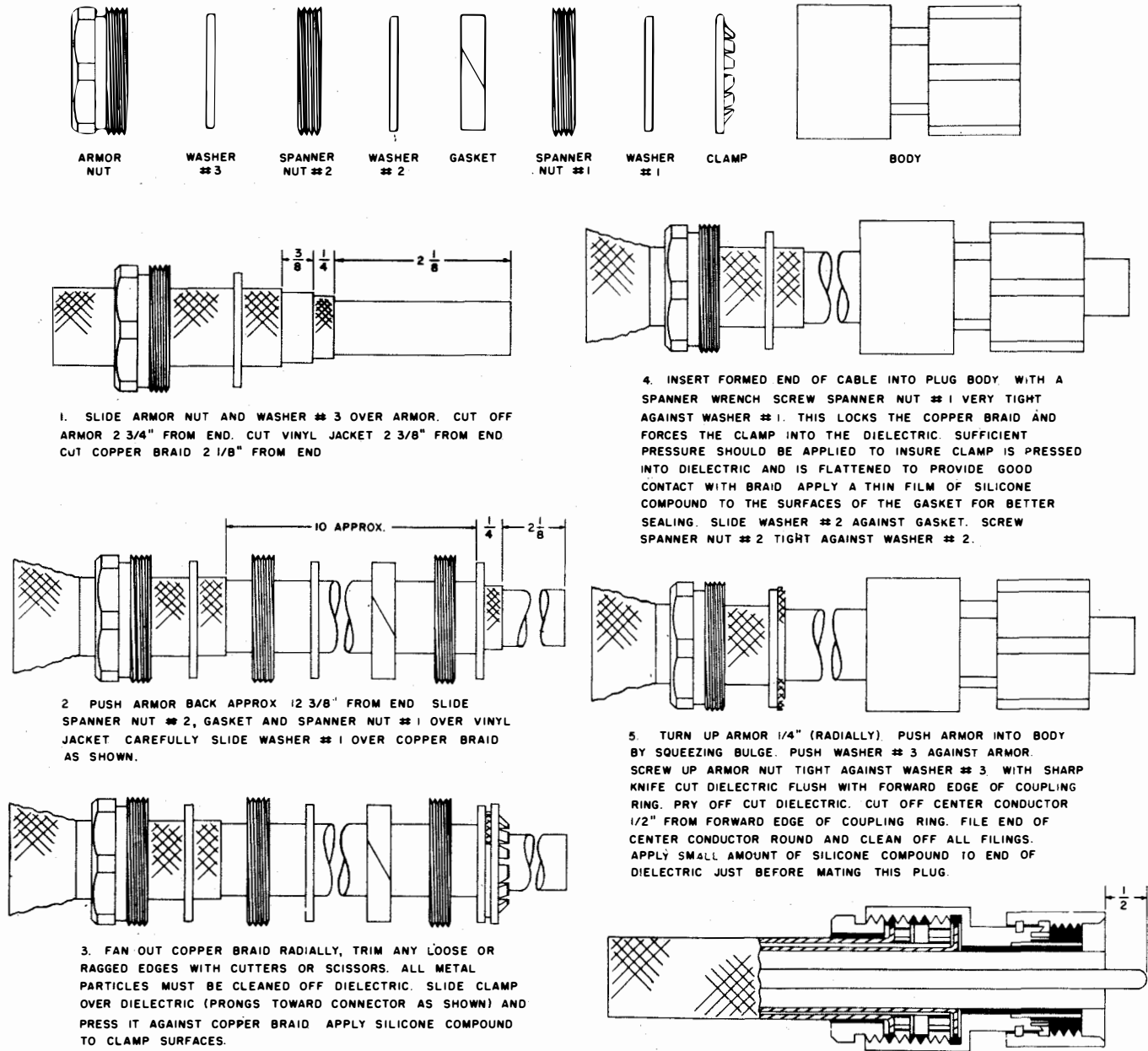

Figure 3-15. Assembly of UG-154/U Connector on RG-18/U Coaxial Cable

should extinguish the power indicator and de-energize the transmitter bay.

Place the SERVICE SELECTOR (U) on the low level radio modulator in FAX position. Patch transmitter to FACSIMILE position. Depress the START button on the control box at the FACSIMILE position. Adjust transmitter for facsimile operation; see paragraph 4d. Place key in transmit, on the control box, at the FACSIMILE position. This should cause the carrier on indicator to come on at the transmitter bay. Observe for correct frequency shift operation. Depress the STOP button on the control box at the FACSIMILE position. This should extinguish the power indicator and de-energize the transmitter bay.

(2) ANTENNA TUNING EQUIPMENT.—All controls and indicators for the initial trial and adjustment of the antenna coupler and r-f tuner are found on the Control-Indicator C-1352/SRT, which is mounted on the radio frequency oscillator front panel.

First, the dummy load must be disconnected from J-3202 on the load adjusting unit and the connector, P-3308, on the RG-18/U interconnecting cable, reconnected to J-3202.

(a) PRESSURIZATION.—Before trial operation of the antenna coupler and r-f tuner takes place, a preliminary check of the pressurization of these two components should be made. Each of the two components should be charged with dry nitrogen until a

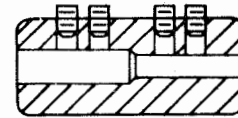
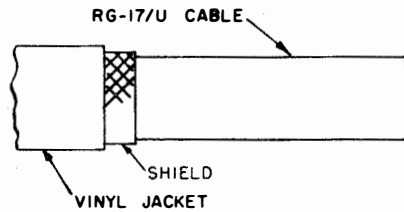

ADAPTER

CBTL A-2011254 WITH
FOUR 6-32 1/4" LG.
HEX SOCKET SET SCREWS

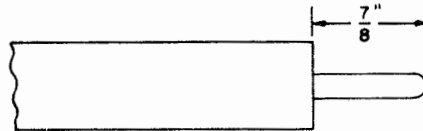

1. FROM REQUIRED LENGTH OF RG-17/U CABLE, PREPARE FIRST EXTRUSION BY REMOVING ENTIRELY THE VINYL JACKET AND THE SHIELD; LEAVING ONLY THE DIELECTRIC MATERIAL AND THE CENTER CONDUCTOR. CUT OFF DIELECTRIC MATERIAL 7/8" FROM THE END, TAKING CARE NOT TO DAMAGE THE EXPOSED LENGTH OF CENTER CONDUCTOR.

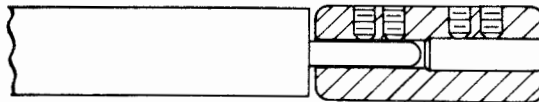

2. SLIDE SMALL DIAMETER HOLE OF ADAPTER OVER CENTER CONDUCTOR OF RG-17/U FIRST EXTRUSION AND TIGHTEN TWO SET SCREWS.

STRAIGHT CONNECTION

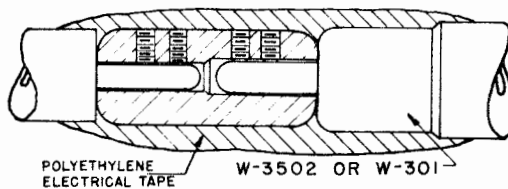

RIGHT ANGLE CONNECTION

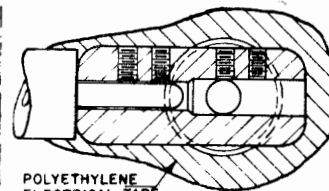

3. AFTER THE ABOVE ASSEMBLIES HAVE BEEN PREPARED, THE CABLES ARE ATTACHED TO W-3502, W-301 IN ACCORDANCE WITH INTERCONNECTING CABLING DIAGRAMS BY SLIDING EITHER LARGE DIAMETER HOLE OF THE ADAPTER OVER THE EXPOSED CENTER CONDUCTORS OF W-3502, AND W-301, TIGHTENING THE REMAINING SET SCREWS TO FORM EITHER A STRAIGHT OR RIGHT ANGLE CONNECTION. WRAP THE ENTIRE CONNECTION WITH POLYETHYLENE ELECTRICAL TAPE.

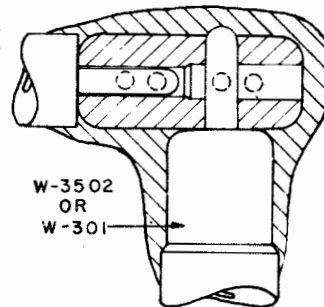

Figure 3-16. Assembly of Adapter (CBTL A-2011254) on RG-17/U First Extrusion Cable

pressure of 20 psi is recorded on each of the pressure gauges. The equipment is supplied charged to the required amount. However, during periods of shipment and storage, all or a portion of the pressurized gas may have leaked out. To pressurize the components, the following typical equipment is required: a cylinder of dry nitrogen; a regulator consisting of a regulator valve, needle valve, delivery pressure gauge and cylinder pressure gauge; a hose with a proper fitting to mate with the regulator at one end and a fitting to mate with the intake valve on the antenna coupler and r-f tuner at the other end. Make the connections to the r-f tuner and/or the antenna coupler as shown on figure 3-19.

If the pressure gauge on the component shows that

there is no pressure in the unit, the unit must first be purged with gas and then charged to the required pressure. If the pressure gauge shows that there is a charge of gas but of insufficient pressure, the unit does not need to be purged before charging to the 20 psi valve. To purge the unit, first close the needle valve on the regulator and then loosen the regulator adjusting screw by turning it clockwise. Open the tank valve on the gas cylinder. Close the adjusting screw until the delivery pressure gauge reads 10 to 15 psi. Note the reading on the cylinder pressure gauge. Open the relief valve on the component by inserting a tool in the hole provided in the relief valve stem and pull the stem against the valve spring tension, holding the stem in this position. Open

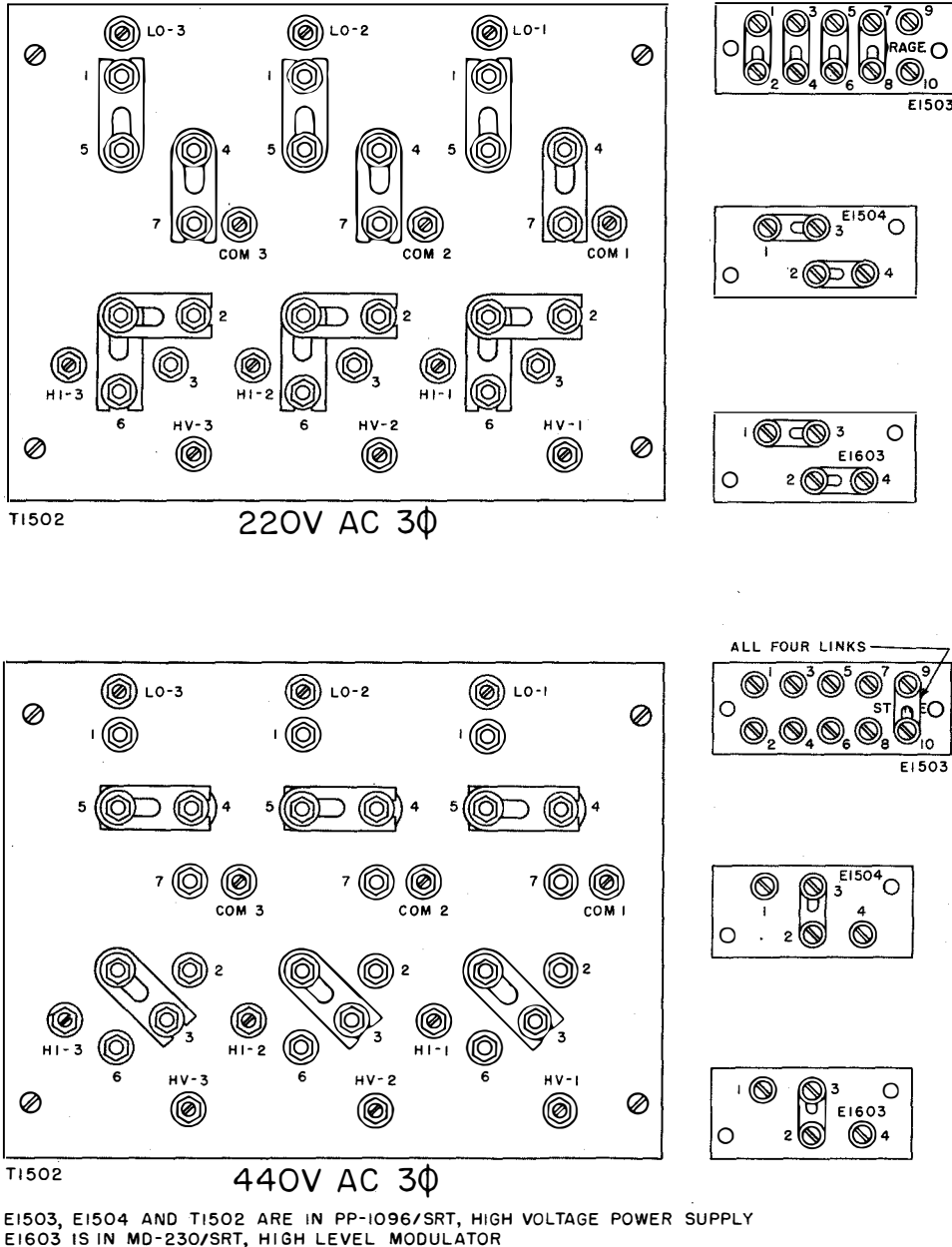

Figure 3-17. Input Power Link Arrangements, Radio Modulator-Power Supply (Booster)

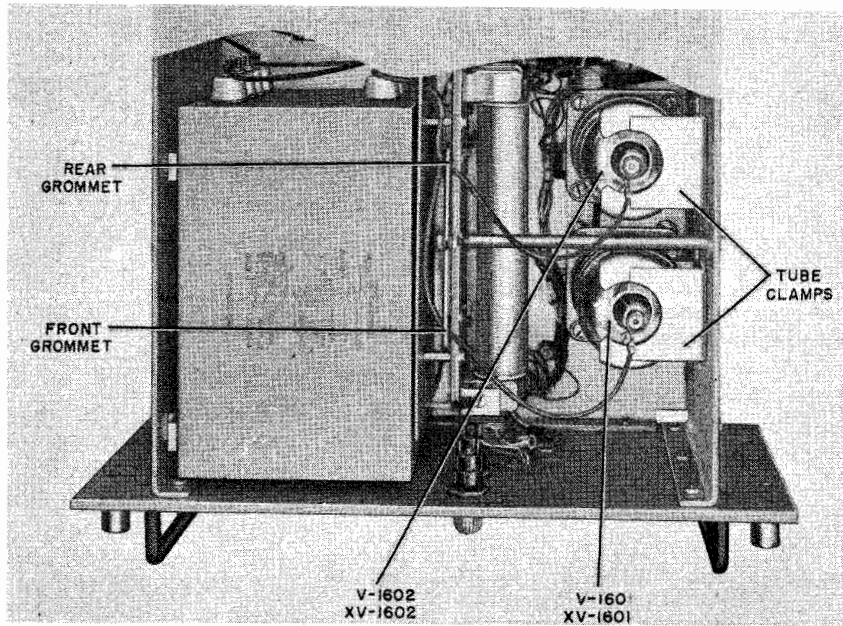

Figure 3-18. Installation of Electron Tubes V-1601 and V-1602

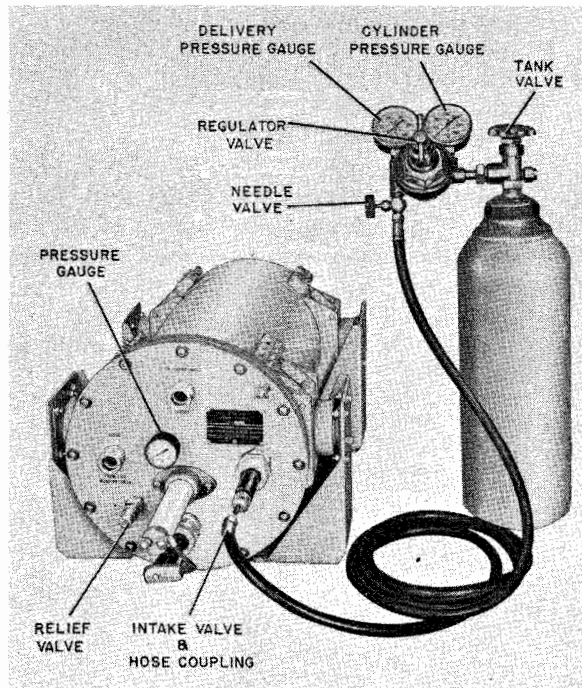

Figure 3-19. Typical Pressurization of Antenna Tuning Equipment

3 Section

Paragraph 7 d (2) (a)

NAVSHIPS 92121(A)

AN/SRT-14, 14A, 15, 15A, 16, 16A

INSTALLATION

the needle valve and purge the component until a drop in gas cylinder pressure of 100 psi is noted, at which time the needle valve should be closed. Release the stem of the relief valve. Open the adjusting screw until the delivery pressure gauge reads 25 to 30 psi. Open the needle valve and charge the component until a reading of 20 psi is read on the pressure gauge on the component, at which time the needle valve on the regulator should be closed. The component is now pressurized; close the tank valve and disconnect the pressurizing equipment. Replace the cap on the intake valve of the unit.

If purging is not required, after the charging equipment is connected, close the needle valve and open the adjusting screw on the regulator. Open the tank valve and close the adjusting screw until the delivery pressure gauge reads 25 to 30 psi. Open the needle valve and charge the component until a reading of 20 psi is read on the pressure gauge on the component, at which time the needle valve on the regulator should be closed. The component is now pressurized; close the tank valve, disconnect the pressurizing equipment, and replace the cap on the intake valve.

(b) TRIAL OPERATION.—Energize the transmitter for 100-watt operation as per paragraph 7d(1) with the exception that the TEST KEY (T) should *not* be operated.

Depress and hold the DOWN push button (AG) on the control-indicator and observe the indicator on the POSITION meter moving down scale. Release the DOWN push button (AG) when the indicator on the POSITION meter stops. Loosen the lock on the ZERO ADJ. control and set this control for a reading of 0 on the POSITION meter. Now depress and hold the UP push button (AF) and observe the indicator on the POSITION meter moving up scale. Release the UP push button (AF) when the indicator on the POSITION meter stops. Loosen the lock on the FULL SCALE ADJ. control and set this control for a reading of 100 on the POSITION meter. As the setting of one of these adjustments slightly affects the other, the above two adjustments should be repeated for the fine setting, after which the two locks should be tight-

ened. Operate the DOWN push button (AG) together with the SLOW push button (AH) and observe the reduced rate of travel of the indicator on the POSITION meter.

If a 35-foot whip antenna is used, select the DIRECT positions on both the TRANSFORMERS (AC) and ANTENNA COUPLER LOADING (AD) controls. Operate the ANTENNA TRANSFER control (AE) to the TUNER IN position and observe that the TUNER IN indicator lights. Depress the UP push button (AF) until the indicator on the POSITION meter reads 100. Set the SWR CALIBRATE control (AB) to 8:1. Operate the TEST KEY (T) on the low level radio modulator and tune the transmitter in the manner outlined in paragraph 7d(1) but to a frequency of 2 mc. Observe the indicator on the SWR BALANCE meter on the control-indicator in the HIGH (red region) portion of the scale. Depress the DOWN push button (AG) watching the SWR BALANCE meter for a dip towards the LOW (green region) portion of the scale. When a dip is found, jog the UP (AF) and DOWN (AG) push buttons to obtain a maximum low indication on the SWR BALANCE meter, moving control (AB) to 4:1 position and then to 2:1 position as the correct tune point is approached. Note that the reading on the POSITION meter, after the low indication has been found on the SWR BALANCE METER, agrees with the approximate value as set forth in the tuning chart located on the under side of the hinged flap, which is mounted on the door covering the frequency selection knobs on the radio frequency oscillator.

If an antenna other than a 35-foot whip is used, follow the step-by-step procedure for initial tuning as described in paragraph 6c of Section 4 of this instruction book.

CAUTION

The ANTENNA COUPLER LOADING CONTROL (AD) *should not* be placed in position c or d when the transmitter is tuned to a frequency above 2.0 megacycles. Operation with control (AD) in position c or d may overheat and destroy coils L-3501 or L-3502 located in the Antenna Coupler CU-372/SRT.