

**General Description TH
Issue 3**

**TELETYPE
TAPE HANDLING
EQUIPMENT**



This equipment is designed to assist you in winding, unwinding or splicing paper tapes used by Teletype message and data communications equipment. Available in various operational speeds and tape storage capacities, these devices serve in a variety of applications. They are low in cost, high in performance and easy to maintain.

Each unit is listed by its Teletype Code or Teletype Part Number. Additional units can be found by referring to the Applications Sections.

Winders and Modification Kits	Page 2	Splicers	Page 5
Unwinders	Page 4	Typical Applications, Model 28	Page 6
Enclosures and Cabinets	Page 5	Typical Applications, Model 35	Page 7
Shelves and Guides	Page 5	Typical Applications, Telespeed	Page 7
Bins	Page 5	Typical Applications, General	Page 8
Reels and Reel Adapters	Page 5		

TW 17 TAPE WINDER*

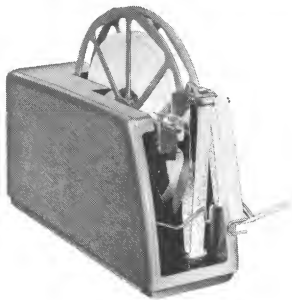

This unit provides easy access to and removal of the tape reel, and is equipped with an indicator contact assembly for an external alarm. Split-reel core allows easy removal of tape. Cabinet is optional, Part No. 148135.

Weight: 18 lbs.	Reel Speed: Up to 2000 WPM at core
Height: 17¼ inches	Reel Size: 15½ inches
Width: 5½ inches	Core Size: 4½ inches
Length: 23½ inches	Capacity: 3000 ft. fully perforated tape 2000 ft. chadless tape
Motor: 115 volt, 50-60 cycle, a.c.	Tape Widths: 11/16, 7/8 and 1 inch

TW 18 TAPE WINDER*



The TW 18 is a rim-driven tape winder which allows reel to be removed from top or front. Its base includes power and driving mechanisms, a tape tension device, clutch engage-disengage mechanism and rollers for tape reel engagement. Cover is optional, Part No. 194770.

Weight: 14 lbs.	Reel Speed: 30 RPM; 300 WPM at core
Height: 13½ inches	Reel Size: 12 inches
Width: 6 inches	Core Size: 2 inches
Length: 17½ inches	Capacity: 2000 ft. fully perforated tape 1000 ft. chadless tape
Motor: 115 volt, 50-60 cycle, a.c.	Tape Widths: 11/16, 7/8 and 1 inch

TW 19 TAPE WINDER*

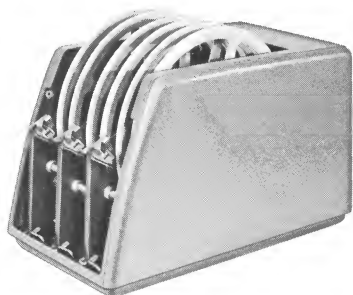

The TW 19 is similar to the TW 18 tape winder, but is equipped with 3 reels which are removed from the top. Equipment mounted on the base is identical to the TW 18. Cover is optional, Part No. 195105.

Weight: 26½ lbs.	Reel Speed: 30 RPM; up to 300 WPM at core
Height: 13½ inches	Reel Size: 12 inches
Width: 10 inches	Core Size: 2 inches
Length: 17½ inches	Capacity: 2000 ft. fully perforated tape 1000 ft. chadless tape
Motor: 115 volt, 60 cycle, a.c.	Tape Width: 11/16, 7/8 and 1 inch

TAPE WINDERS

146821 TAPE WINDER*

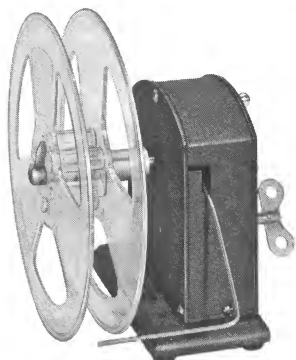

This spring-driven tape winder is equipped with a special spindle and plastic reel directly interchangeable with those of High Speed Telespeed Equipment. It includes provisions for fixed mounting.

Weight: 4½ lbs.
 Height: 7½ inches
 Width: 7½ inches
 Length: 4½ inches
 Motor: Spring driven

Reel Speed: Up to 1000 WPM
 Reel Size: 7½ inches
 Core Size: 2 inches
 Capacity: 350 ft. fully perforated tape
 170 ft. chadless tape
 Tape Widths: 11/16, 7/8 and 1 inch

PART NO. 146822 is a modification kit which adapts spring-driven tape winders for handling the plastic reels used in Telespeed Tape-to-Tape Systems. It can be used on the following winders: 115739, 115753, 115754 and 123587.

TW 200 TAPE WINDER*

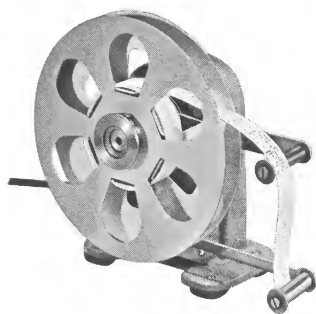

The TW 200 can be adapted to wind tape from either the right or the left by simple relocation of a few parts.

Weight: 6½ lbs.
 Height: 9⅞ inches
 Width: 6 inches
 Length: 10 inches
 Motor: 115 volt, 60 cycle, a.c.

Reel Speed: 60 RPM; up to 914 WPM at core
 Reel Size: 8 inches
 Core Size: 3 inches
 Capacity: 600 ft. fully perforated tape
 300 ft. chadless tape
 Tape Widths: 3/8, 15/32, 11/16, 7/8 and 1 inch

PART NO. 146626 is a modification kit for adapting existing tape winders, such as the TW 200, for handling the plastic reels on High Speed Telespeed Equipment.

TW 203 TAPE WINDER*

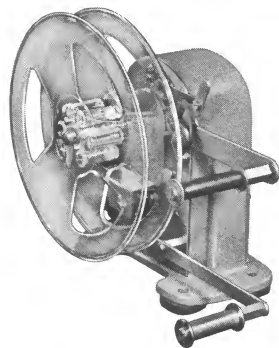

The TW 203 is similar to the TW 200 but is equipped with a special spindle and plastic reel directly interchangeable with those in a Telespeed Tape-to-Tape System. The winder includes provisions for fixed mounting positions.

Weight: 6½ lbs.
 Height: 9⅞ inches
 Length: 10½ inches
 Width: 6¼ inches
 Motor: 115 volt, 60 cycle, a.c.

Reel Speed: 60 RPM; up to 628 WPM at core
 Reel Size: 7½ inches
 Core Size: 2 inches
 Capacity: 650 ft. fully perforated tape
 325 ft. chadless tape
 Tape Widths: 11/16, 7/8 and 1 inch

TW 204 TAPE WINDER*

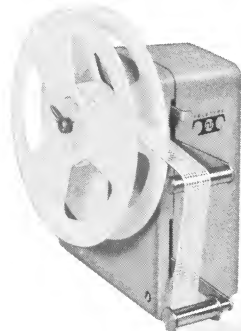

Like the TW 203, the TW 204 has a plastic reel directly interchangeable with those on Telespeed equipment, but is especially suitable for use with Model 35 equipment.

Weight: 7½ lbs.
 Height: 9⅞ inches
 Length: 10½ inches
 Width: 6¼ inches
 Motor: 115 volt, 60 cycle, a.c.

Reel Speed: 60 RPM; up to 628 WPM at core
 Reel Size: 7½ inches
 Core Size: 2 inches
 Capacity: 650 ft. fully perforated tape
 325 ft. chadless tape
 Tape Widths: 11/16, 7/8 and 1 inch

TAPE UNWINDERS



146815 TAPE CENTER UNWINDER

The 146815 tape center unwinder is capable of accepting perforated tape for subsequent center pay-out to a tape reader operating at speeds up to 100 words per minute.

Reel Diameter: 12 inches	Capacity: 1800 ft. fully perforated tape
Weight: 2 lbs.	1000 ft. chadless tape
Core Size: 2½ inches	Tape Widths: 11/16, 7/8 and 1 inch

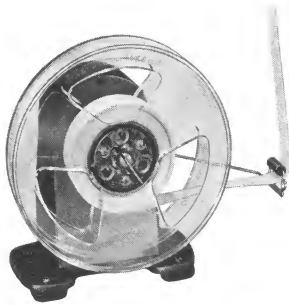

146892 TAPE UNWINDER

The 146892 tape outside unwinder operates at speeds up to 1050 words per minute. It is equipped with a standard Telespeed Tape-To-Tape system reel, easily removed for renewing the tape supply. A tension-limiting arm operates a braking mechanism to prevent reel over-run and to maintain proper tension while the unit is operating. Positioning a lever permits free-wheeling of the reel.

Height: 11 inches	Weight: 3½ lbs.
Width: 10½ inches	Capacity: Up to 800 ft. fully perforated tape
Length: 6 inches	Up to 400 ft. chadless tape
	Tape Widths: 11/16, 7/8 and 1 inch

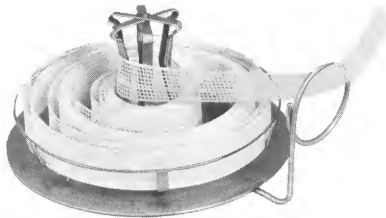

199935 TAPE CENTER UNWINDER

The 199935 tape center unwinder has a magnetic base and can accept tape from Telespeed reels. It operates at speeds up to 500 words per minute.

Reel Diameter: 6 inches	Capacity: 400 ft. fully perforated tape
Weight: 1 lb.	200 ft. chadless tape
Core Size: 2 inches	Tape Widths: 11/16, 7/8 and 1 inch

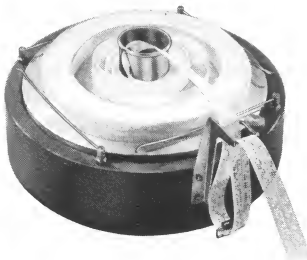

TF 200 TAPE CENTER UNWINDER (POWER DRIVEN)*

The TF 200 tape feeder is a power driven, center-unwind unit. It automatically adjusts to the requirements of high-speed transmitters or tape readers by means of a tape sensing arm which actuates the feeder's motor. Tape is fed from the center of the tape roll at speeds up to 2000 words per minute. Tape roll diameter is 12¾ inches.

Diameter: 15 inches	Height: 7 inches
Weight: 9 lbs.	Capacity: 2000 ft. fully perforated tape
Core Size: 2½ inches	1000 ft. chadless tape
	Tape Widths: 11/16, 7/8 and 1 inch



TUW 200 TAPE UNWINDER

The TUW 200 is a high-capacity high-speed tape outside unwinder for general applications. It has no reel and can accommodate up to 3,000 feet of punched or unpunched tape which it can feed out at speeds up to 2400 words per minute.

Height With Tape: 15 inches	Weight: 27 lbs.
Width: 5¾ inches	Capacity: Up to 3000 ft. fully perforated tape
Length: 20½ inches	Up to 1500 ft. chadless tape
	Tape Widths: 11/16, 7/8 and 1 inch

OTHER TAPE ACCESSORIES

TAPE APPARATUS ENCLOSURES AND CABINETS

See Typical Applications Section, Pages 6 and 7.

TAPE APPARATUS SHELVES

See Typical Applications Section, Pages 6, 7 and 8.

TAPE GUIDES

See Typical Applications Section, Pages 6 and 7.



199931 INTERMEDIATE TAPE STORAGE BIN

The 199931 storage bin has sides of heavy-gauge plexiglass. It is designed for applications in which tape input and output approximate 60 to 100 words per minute as with Model 32 or 33 equipment. It holds about 100 feet of 11/16, 7/8 or 1 inch fully perforated or chadless tape. The bin measures 4 inches wide by 16½ inches long and 24 inches high, and weighs 8 lbs. It has provisions to accept waste chad from tape punching operations. See application on Page 8 and see Page 6 for another storage bin.

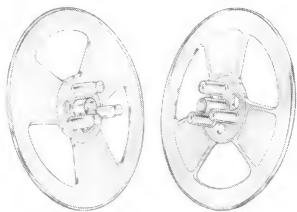

145911 REEL

This tape reel is used in the Telespeed Tape-To-Tape system as well as some other tape winders and unwinders shown in this folder. It handles up to 800 ft. of fully perforated tape or 400 ft. of chadless tape, from 11/16 to one inch wide. Reel diameter is 7½ inches with a 2-inch core. For more tape reels, see Page 8.

REEL ADAPTERS

See Typical Applications Section, Page 8.

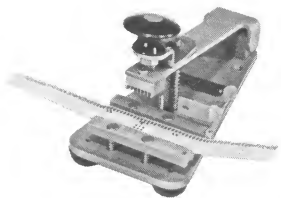

99214 TAPE SPLICER

This tape splicer joins the ends of two pieces of 11/16-inch chadless tape by compressing the partial perforations of one tape through the openings in the other. Thus it requires no bonding agent. Transmission can be accomplished without interruption after splice is made. It weighs 1¾ lbs. and measures 4 inches high by 3½ inches wide and 6½ inches long.

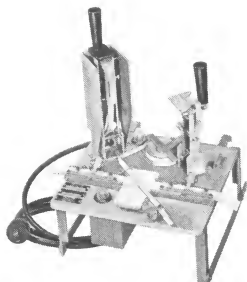

LTS TAPE SPLICER

The Model 28 LTS tape splicer is designed to single butt splice the end of a nearly depleted roll of 11/16-inch tape to the beginning of a fresh supply. This assures a continuous flow of tape. The bonding agent is ¼-inch wide #9 white manifold onion skin, .0015 inch thick. The 6¼-lb. unit can be used 90 seconds after power is turned on. It measures 12½ inches high by 8½ inches wide and 9¼ inches long.

TYPICAL MODEL 28 APPLICATIONS

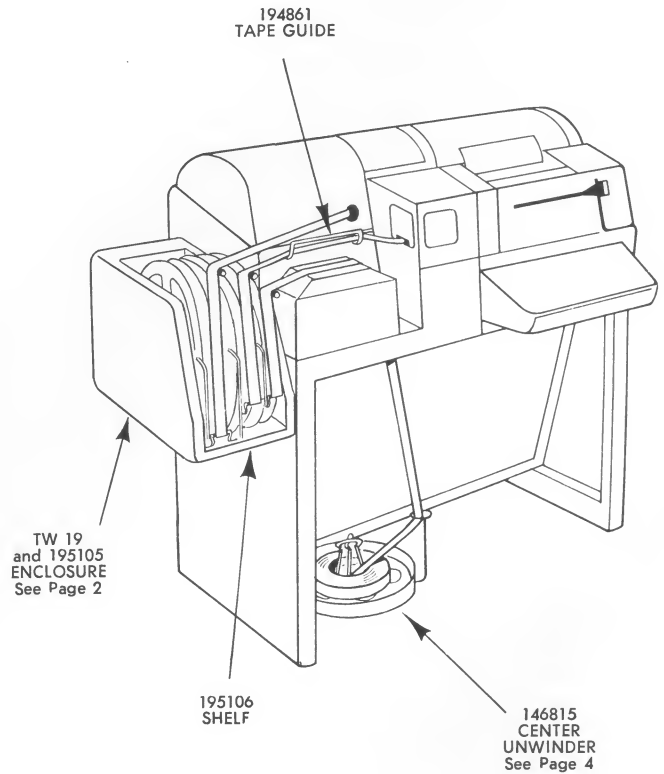
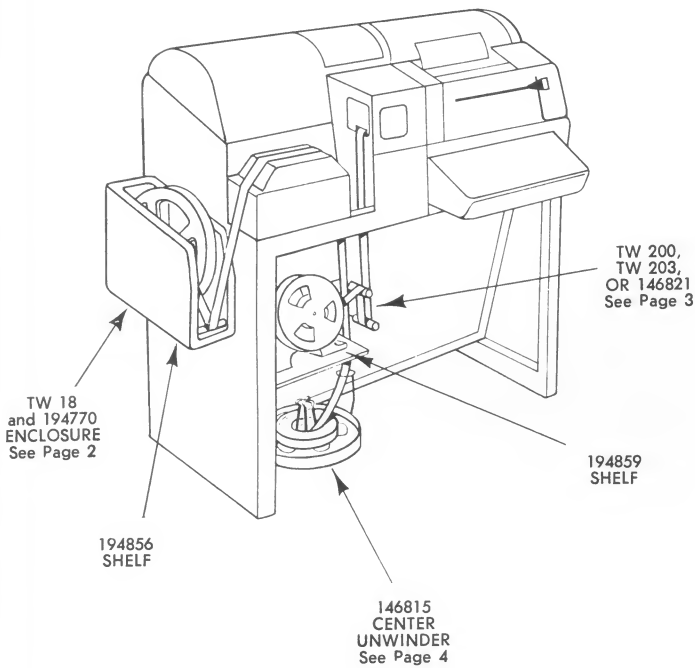
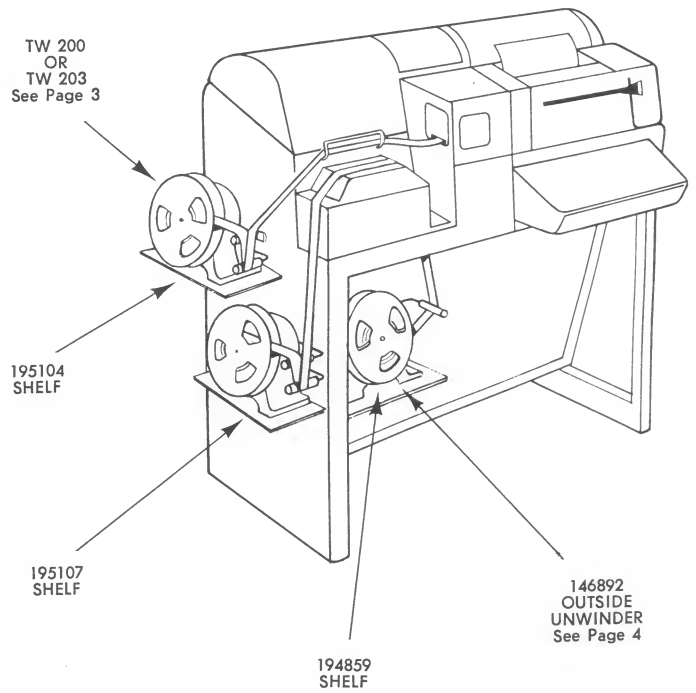
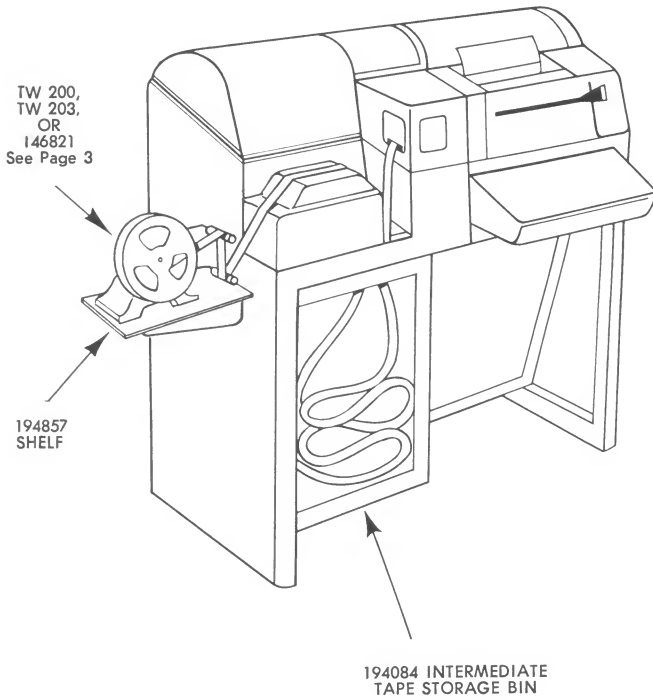

TYPICAL MODEL 35 APPLICATIONS

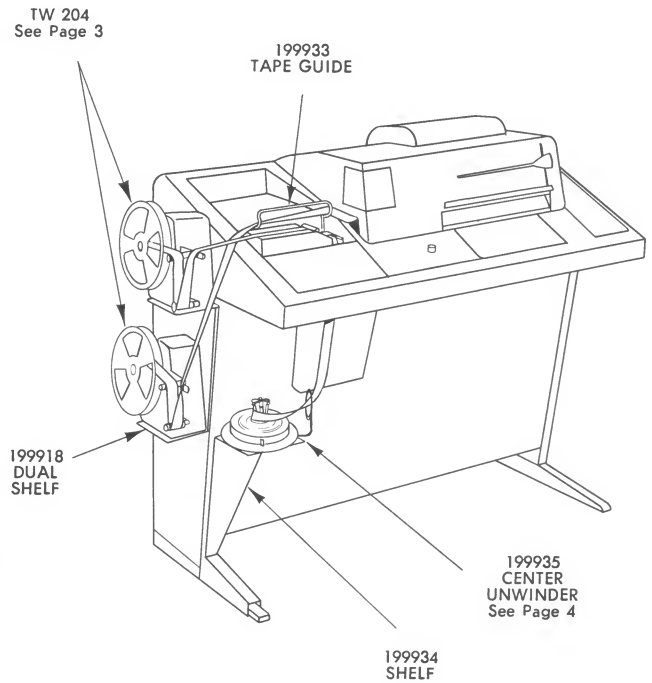
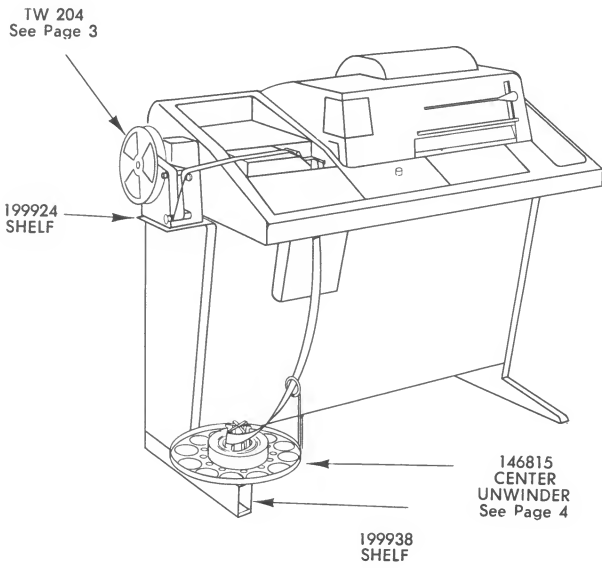

TYPICAL TELESPEED APPLICATIONS

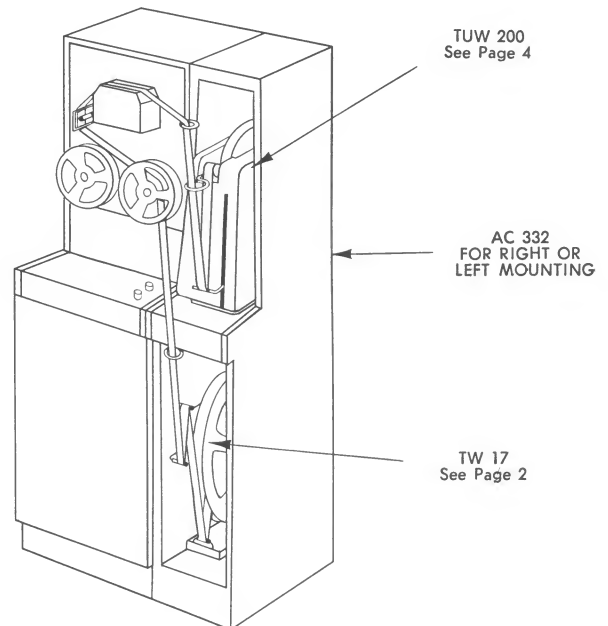
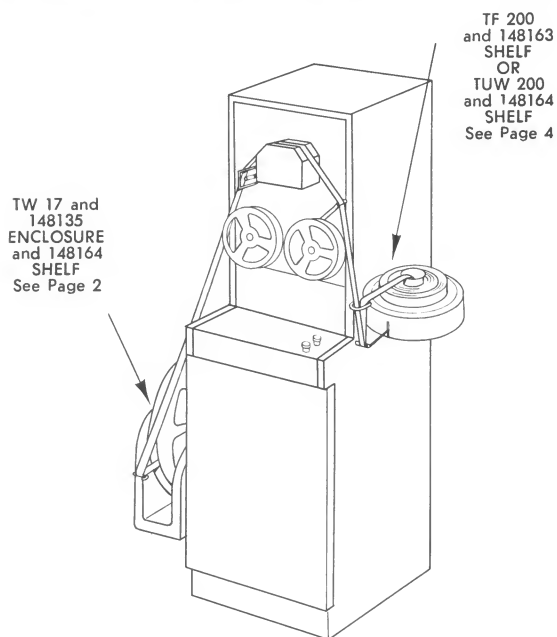

TYPICAL GENERAL APPLICATIONS

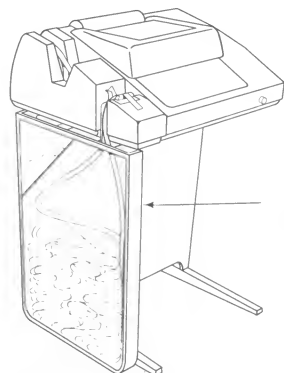

199931
INTERMEDIATE
TAPE STORAGE BIN
See Page 5

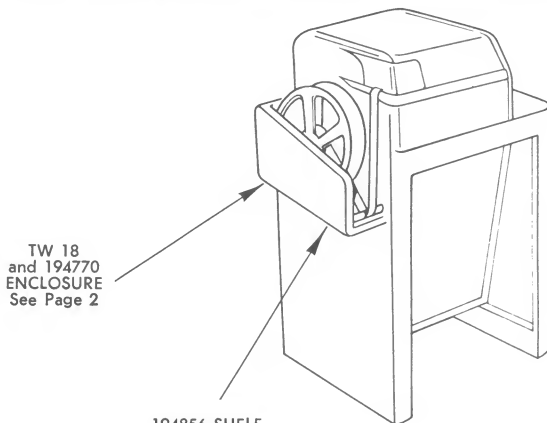

TW 18
and 194770
ENCLOSURE
See Page 2

194856 SHELF

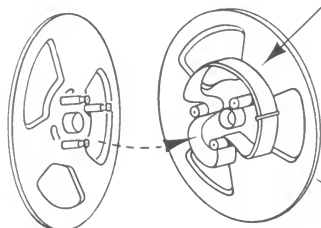

USE 3/4-INCH ADAPTER 146698
IF ACCUMULATED TAPE IS TO
BE TRANSFERRED TO A CENTER
UNWIND REEL

USE 4 1/2-INCH ADAPTER 146806
IF TAPE IS TO BE TRANSFERRED
TO A REEL WITH A 4 1/2-INCH
DIAMETER CORE

145911 REEL
See Page 5

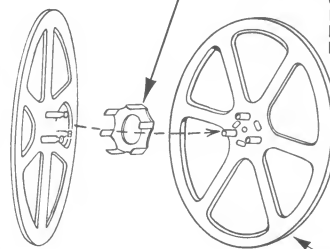

USE ADAPTER 194442
IF TAPE IS TO BE TRANSFERRED FROM
A 1-INCH 194769/162823 REEL TO A
REEL WITH A 3/4-INCH CORE

USE ADAPTER 199468
IF TAPE IS TO BE TRANSFERRED
FROM AN 1 1/16-INCH 162824/162823
REEL TO A REEL WITH A 3/4-INCH CORE

RIM DRIVEN REEL
WITH 2,000 FT.
CAPACITY FULLY
PERFORATED TAPE

A TELETYPE APPLICATIONS SPECIALIST . . .

is always on hand to answer questions or to assist you in system planning. Call or write to him soon!

GENERAL OFFICES

Teletype Corporation
5555 Touhy Avenue
Skokie, Illinois '60078
PHONE: 676-1000, Skokie
Direct Distance Dialing
Area Code 312

TWX: 910-223-3611
(24-hour automatic
answering service)
W. U. Service on premises
TELEX: 02-5451

GOVERNMENT LIAISON OFFICE

Teletype Corporation
425—13th Street, N.W.
Washington, D.C. 20004
PHONE: ME 8-1016
Direct Distance Dialing
Area Code 202

