

INSTRUCTIONS FOR INSTALLING THE 182052 MODIFICATION
KIT ON MODEL 32/33 TYPING UNIT TO PROVIDE AN END-
OF-LINE BELL 9 CHARACTERS FROM THE END OF A
69 CHARACTER LINE

1. GENERAL

a. The 182052 modification kit provides the Model 32/33 Typing Unit with an end-of-line signal on the 60th to 64th character.

b. When the unit being modified has the automatic line feed carriage return, the 183498 automatic code bar must be replaced with one of the following (not furnished with the kit):

183495 Code Bar for a 69 character line.
183496 Code Bar for a 72 character line.
183497 Code Bar for a 74 character line.

c. When using the above code bars, the bell will ring not only at about the 61st character but also may ring during the machine cycle where automatic carriage return occurs.

d. It is not recommended that the automatic carriage return-line feed feature be used with sprocket feed machines.

e. The 182052 kit consists of:

1	82532	Screw, Shoulder	1	181307	Lever/Post and Hub
1	119649	Ring, Retaining	1	181308	Roller
1	181304	Latch	1	182294	Post, Eccentric
1	181305	Spring	1	183498	Bar, Code (End-of-Line)

f. For parts information, on other than parts in the kit, see Teletype Parts Bulletin 1184B.

2. INSTALLATION (Figures 1 and 2)

a. Place the carriage to the extreme left of the printer so that the dash pot piston is located in the dash pot cylinder.

b. Remove the 84575, 180956 and 180922 springs from the right end of the code bar basket mechanism. Remove the 180921 spring bracket. Remove the 180948 code bar and replace it with the 183498 code bar, reverse the procedure for assembly being careful to re-assemble the springs in their proper place.

c. Remove the 180788 carriage rear rail, this can be done without removing the carriage being careful to slide the bar out to the right. Assemble the 181307 lever with post and hub, 181305 spring, 181304 latch and 82532 screw. Apply a slight film of "glyptal" to the threads of the 82532 shoulder screw just before assembly. (See Figure 1)

d. Remove the 180472 eccentric post, 180470 roller and 119649 retaining ring, discard these parts but retain the 3606 nut and 124177 lockwasher, from the carriage lower plate mechanism.

e. Assemble the 181308 roller, 182294 eccentric post and 119649 retaining ring supplied in this kit to the carriage lower plate mechanism using the 3606 nut and 124177 lockwasher previously saved. (See Figure 2)

f. Re-assemble the carriage rear rail.

g. Make the Carriage Rear Roller and Rail Adjustments as found in Teletype Bulletin 273B.

h. Oil the 183498 code bar, 180788 carriage rear rail, 181304 latch, 180470 roller, and 181305 spring.

*

*

*

50342S

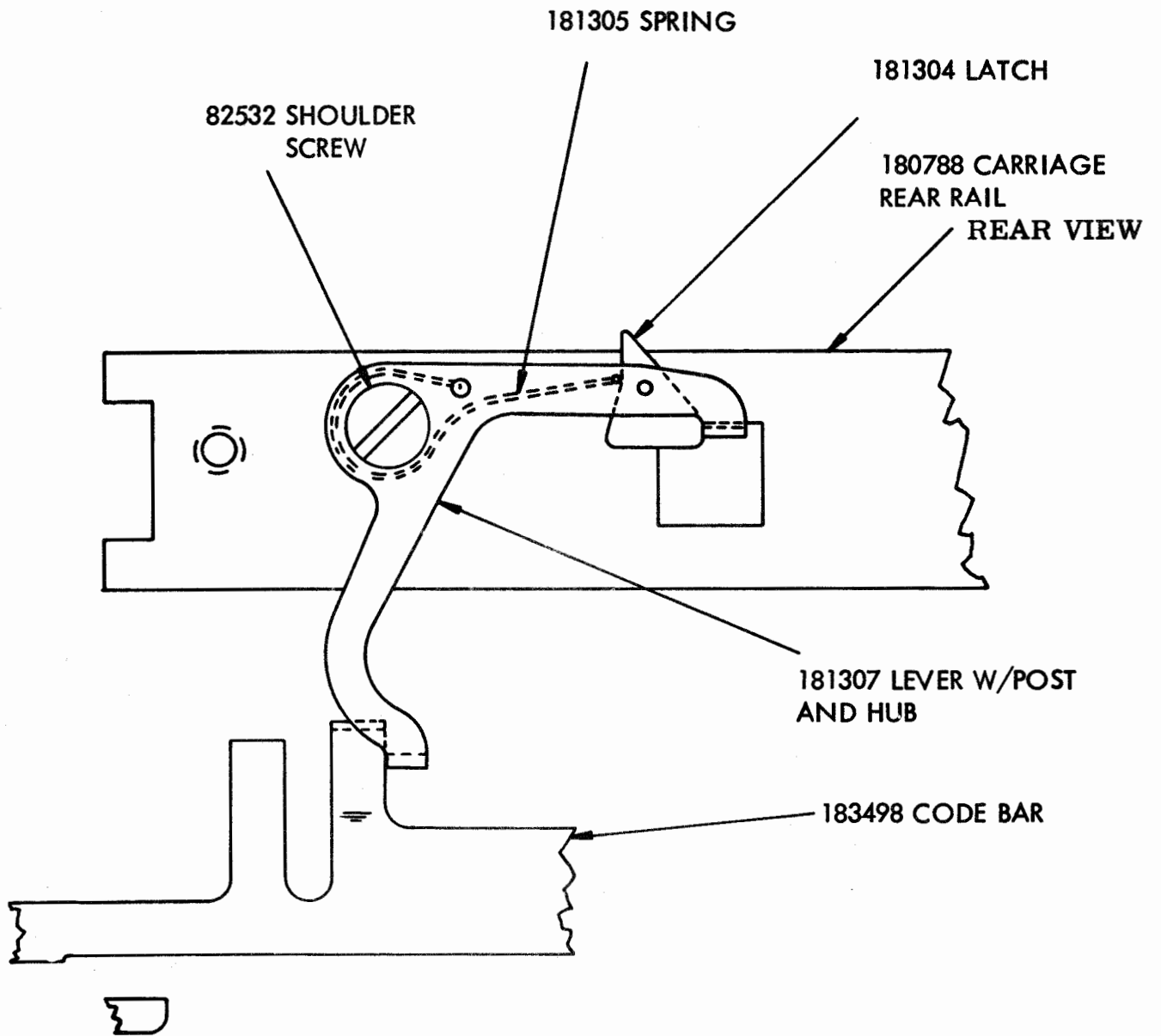

FIGURE 1

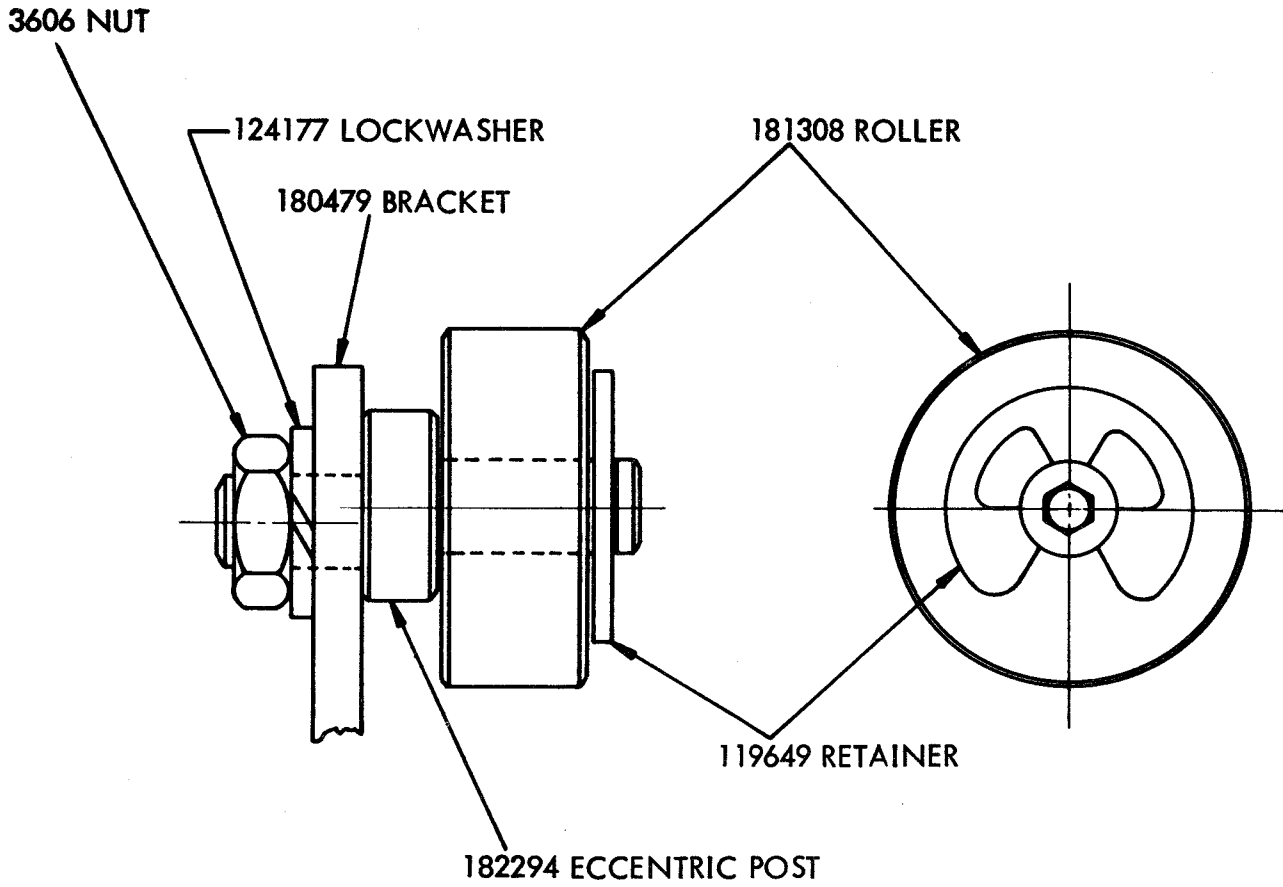

FIGURE 2