

RTTY ELECTRONICS
TELETYPE=Sales-Service-Parts
PO Box 20101 El Sobrante, Ca.
94820. (510)222-3102
mr_rtty@pacbell.net

Teletype Corporation
Skokie, Illinois, U.S.A.

Specification 50252S
NAVSHIPS 0285-079-0700

*Issue 2, Page 1
May, 1965

INSTRUCTIONS FOR INSTALLING 179615 OR 179616 MODIFICATION
KIT (NAVY NOMENCLATURE MK-841/UG OR MK-840/UG ,
RESPECTIVELY) TO REDUCE RADIO-FREQUENCY NOISE IN
TELETYPEWRITER TYPING REPERFORATOR SET TT-192/UG , TT-192A/UG ,
TT-253/UG OR TT-274/UG

1. GENERAL

a. The 179615 or 179616 modification kit is applicable to Teletypewriter Typing Reperforator Sets as indicated below:

<u>MODIFICATION KIT</u>	<u>SET</u>	<u>NAVSHIPS MANUAL</u>
179615 (Navy Nomenclature MK-841/UG)	TT-253/UG	94456
179616 (Navy Nomenclature MK-840/UG)	TT-192/UG , TT-192A/UG or TT-274/UG	94456

b. The general function of the 179615 or 179616 modification kit is to provide a selector magnet circuit (179615 and 179616 kits) and a signal generator circuit (179615 kit) that are essentially free of radio-frequency interference. This is accomplished by the provision of a 192730 selector magnet driver (179615 and 179616 kits) which furnishes the driving current to the selector magnets, and a 192740 low-level keyer, 179643 filter network, and other special signal generator components (179615 kit). The function of the 192740 low-level keyer and 179643 filter network is to provide a low-level voltage and current through the keyboard signal generator contacts and subsequent amplification of these signals to produce standard current levels of 20 and 60 milliamperes at 48 volts dc loop potential. Also, the low-level keyer provides a 20 or 60 milliamperes 24 volt dc power source which may be used to furnish battery for a test loop or signal line where a maximum of five low-level keyers and five selector magnet drivers are used.

c. The 179615 or 179616 modification kit is intended for installations which require suppression of radio-frequency noise, and for local transmission circuits only on short signal line loops, generally less than 1,000 feet in length and with loads having low radio-frequency interference characteristics.

d. The 179615 or 179616 modification kit will operate satisfactorily with up to ten 192730 selector magnet drivers and ten 192740 low-level keyers on one signal line; however, if the electrical motor control feature is used on these units, the number of each of these units that can be placed on the signal line is limited to no more than eight at 60 milliamperes line current and six at 20 milliamperes line current (assuming zero line resistance). External resistance must be added in series with the signal line loop to limit the current to either 60 or 20 milliamperes, whichever is used.

e. The 179615 or 179616 modification kit is operable in conjunction with the following or similar radio-frequency noise suppression components:

(1) Pertains to 179616 kit - A 192740 low-level keyer the purpose of which is to amplify the low-level neutral start-stop signals of an associated transmitter or keyboard unit to the signal line.

(2) Pertains to 179615 and 179616 kits - A 192750 rectifier, the purpose of which is to supply a source of 60 milliampere 48 volt direct current for the signal line.

f. The 179615 or 179616 modification kit should be operated on 48v dc, 20 or 60 milliampere neutral signal line current only through strapping options in the 192730 selector magnet driver (179615 and 179616 kits) and 192740 low-level keyer (179615 kit).

g. Pertains to 179615 and 179616 kits - The 192730 selector magnet driver output current should be 60 milliamperes regardless of whether the unit is operated in a 60 ma. or 20 ma. signal line (see above Paragraph f.). The driver should operate the associated reperforator selector magnets with a minimum of 60 points of range. The selector magnets may be readjusted to meet this requirement.

h. Pertains to 179615 and 179616 kits - The ac power input to the self-contained power supply of the driver and keyer should be 115 ± 10 per cent volts, 50 or 60 cps.

i. Pertains to 179615 kit - The selector magnet may be blinded by making an electrical connection between the two "Blind" terminals on the selector magnet driver circuit card. Refer to 7220WD Wiring Diagram included in the kit.

j. The 179615 or 179616 modification kit is operable at speeds up to 100 wpm (7.42 unit code). Brackets and associated hardware are provided in the kit for "tabletop," "shelf," or "wall" mounting of the 192730 selector magnet driver (179615 and 179616 kits) and 192740 low-level keyer (179615 kit). The 179615 kit provides a contact assembly containing gold plated contacts for the keyboard signal generator. Current through the gold plated contacts during operation, testing, or repair of the signal generator should be limited to 70 microamperes at 3 volts dc. Operation of the contacts with standard 20 or 60 milliampere current may damage the gold plating of the contacts sufficiently to impair low-voltage operation.

k. The 179615 and 179616 modification kits consist of:

			179615	179616
1	2191	Lockwasher	X	
	2449	Lockwasher	8	4
1	3598	Nut	X	
4	7002	Washer, Flat	X	
1	7192WD	Diagram, Actual Wiring		X
1	7193WD	Diagram, Schematic Wiring		X

			179615	179616
1	7194WD	Diagram, Actual Wiring		X
1	7195WD	Diagram, Schematic Wiring		X
1	7220WD	Diagram, Actual Wiring	X	
1	7221WD	Diagram, Schematic Wiring	X	
2	82474	Terminal		X
2	84082	Screw	X	
	85559	Washer, Flat	16	8
	89305	Screw	8	4
	92146	Nut	8	4
1	110743	Lockwasher	X	
1	121243	Clamp, Cable	X	
2	121246	Clamp, Cable	X	
1	121248	Clamp, Cable		X
2	151442	Screw	X	
1	151880	Nut	X	
1	153538	Screw	X	
1	153622	Jumper		X
1	153803	Jumper		X
1	153817	Screw	X	
2	155750	Sleeve, Insulating		X
1	179639	Contact Assembly	X	
1	179643	Filter Network Assembly	X	
1	192730	Driver Assembly, Selector Magnet	X	X
1	192740	Keyer Assembly, Low-Level	X	
1	195187	Screw	X	
1	195651	Box, Contact	X	
1	195652	Cover, Contact Box	X	
1	199193	Bushing	X	
1	199196	Link Assembly	X	
1	304561	Cable Assembly	X	
	304671	Bracket	4	2
1	304685	Cable Assembly		X
1	304937	Cable Assembly	X	
1	304938	Cable Assembly	X	
1	309499	Bracket	X	
1	310148	Plate, Identification (Navy Only)	X	
1	310149	Plate, Identification (Navy Only)		X

2. THEORY OF OPERATION

a. For 179615 Modification Kit - The keyboard signal generator is equipped with a contact assembly which has the toggle and spacing contact strapped together and contains gold plated contacts. A non-metallic link is used to drive the toggle of the signal generator in place of the steel link. A low voltage and current (3v dc at about 70 microamps) is supplied to the keyboard signal generator contacts. This low-level signal is fed to the low-level keyer through shielded leads to prevent a pick-up of stray

radio-frequency noise in the cover. In the keyer, the low-level signal from the signal generator is amplified for use in keying a 48 volt dc 20 or 60 milliampere signal line. A 20 or 60 milliampere 24 volt dc power source is provided on the low-level keyer to furnish battery for a test loop or signal line where a maximum of five low-level keyers and five selector magnet drivers are used.

b. For 179615 or 179616 Modification Kit - In the receiving selector magnet driver the signal line current pulses received from a 192740 low-level keyer are repeated in a local loop (60 ma.) to the selector magnets. Current for the selector magnets is supplied by a local power supply in the selector magnet driver. The signal line loop battery is normally supplied from a 192750 rectifier which provides a source of 48v dc power that is relatively free of radio-frequency noise for the signal line.

3. INSTALLATION

NOTE

For parts referred to, other than those included in the modification kits, refer to NAVSHIPS Manual 94456.

a. 179615 MODIFICATION KIT FOR TT-253/UG SET

(1) The 179615 modification kit is wired for 60 milliampere operation as shipped from the factory. For 20 milliampere operation change the strapping as follows before installation:

(a) 192730 selector magnet driver

1. Remove the circuit card from the assembly by removing the four cover mounting screws and the circuit card nut. The driver circuit card is viewed with the power resistors on top of the unit toward the observer.

2. Change strapping as shown in Figure 1. Replace the circuit card, circuit card nut, cover, and the four cover mounting screws.

NOTE

Regardless of current input, the selector magnet driver output to the selector magnets should always be 60 milliamperes.

(b) 192740 Low-Level Keyer - Remove the circuit card from the assembly by removing the four cover mounting screws and the circuit card nut. The keyer circuit card is the left circuit card as the unit is viewed with the power resistor on top of the unit toward the observer.

Change strapping as shown in Figure 2. Replace the circuit card, circuit card nut, cover, and the four cover mounting screws.

(2) Remove the cover from the set. Disconnect the 159541 connector plug from its mating receptacle on the keyboard to remove all power from the set.

(3) Remove the typing reperforator unit from the keyboard base by removing the three 76278 mounting screws, 2449 lockwashers and 2846 flat washers. The typing reperforator selector magnets must be wired for 60 milliampere operation. If necessary, change selector magnet wiring in accordance with applicable wiring information in NAVSHIPS Manual 94456.

(4) Remove the keyboard base from the cover base plate assembly by removing the four 151549 mounting screws.

(5) Remove and discard the 154131 contact box cover from the keyboard signal generator by removing the 3640 lockwasher and 3599 nut. Retain the nut and lockwasher.

(6) Remove the signal generator cable and 154166 arc suppressor connections to the contact box by removing the two 1293 screws and 110743 lockwashers. Remove the cable grommet from the contact box. Discard the 154166 suppressor. Retain the 1293 screws and 110743 lockwashers.

(7) Disconnect (and retain) the 86304 spring from the 156644 link. Disengage the link from the 154010 bail. Remove the two 151632 screws, 2191 lockwashers and 7002 flat washers that secure the 154056 contact box mounting bracket to the signal generator front plate. Retain all mounting hardware. Remove the contact box and bracket assembly from the unit. Remove the 125126 screw, 90791 lockwasher, 151182 insulating washer, and 156663 bushing that secure the 151171 contact toggle to the 156644 link. Discard the 156663 bushing and 156644 link.

(8) Remove the 151880 nut, 151731, 151686, and 151152 screws with 3640 lockwashers that secure the 154130 contact box with contact assembly to the 154056 bracket. Retain the 151152 screw, three 3640 lockwashers, 151880 nut, and 154056 bracket. Discard the remainder. Mount the 195651 contact box to the 154056 bracket using the retained 151152 screw and 3640 lockwasher. Mount the 179639 contact assembly in the 195651 contact box using the 195187 screw, 153817 screw, and the retained 151880 nut and 3640 lockwashers. See Figure 3.

(9) Insert the 199196 link assembly in the contact box slot. Connect the 199196 link to the contact toggle using the 125126 screw, 90791 lockwasher, 151182 insulating washer (retained in Paragraph (7)), and 199193 bushing. See Figure 3. Reinstall the contact box assembly and 154056 bracket in the signal generator using the two 151632 screws, 2191 lockwashers, and 7002 flat washers retained in Paragraph (7). Engage the link with the 154010 bail. Connect the 86304 link spring.

(10) Make the signal contacts adjustment as specified in Paragraph 4. of this specification.

(11) Install the 179643 filter network assembly in the contact box (as shown in Figure 3) by means of its mounting screws and lockwashers. Route the grommet end of the 304561 cable assembly down through the opening between the base and the 161951 bracket, just behind the tape supply reel mounted at the left side. Route the 304561 cable straight back, along the left side of the base, and up to the signal generator as shown in Figure 4. Connect the red and blue leads of the 304561 cable to the filter network in accordance with 7220WD Wiring Diagram, (included in the kit), using the two 1293 screws and 110743 lockwashers retained in Paragraph (6). Connect the ground lead (G) of the 304561 cable to the filter network by means of the 195187 screw, 151880 nut, and 110743 lockwasher. Insert the grommet of the 304561 cable in the 195652 contact box cover cut-out; secure the 195652 cover on the 195651 contact box using the 3640 lockwasher and 3599 nut retained in Paragraph (5).

(12) Remove and discard the front 121242 cable clamp that secures the signal generator leads of the 161878 base cable by means of the 153817 screw, 7002 flat washer, 3640 lockwasher and 3599 nut. Route and tie the 161878 signal generator cable leads back to the main portion of the 161878 cable. Secure the 304561 cable to the base using the 121243 cable clamp and the retained 153817 screw, 7002 flat washer, 3640 lockwasher and 3599 nut. See Figure 4.

(13) Remove and discard the 121244 cable clamp that secures the 161878 cable to the left rear of the base by means of the 3598 nut, 7002 flat washer, 2191 lockwasher and 151632 screw. Remove the 151631 screw, 2191 lockwasher, 7002 flat washer and 3598 nut that secures the 161878 cable ground lead to the base. Discard the 151631 and 151632 screws. Use two 151442 screws and three 7002 flat washers in addition to the two retained 7002 flat washers, 2191 lockwashers and 3598 nuts to mount the 309499 bracket and 121246 cable clamp (with the 161878 and 304561 cables) to the base as shown in Figure 4. Insert the wires of the 304561 cable through the 309499 bracket opening and secure the 179748 connector plug of the cable to the 309499 bracket by means of the connector nut and locking ring. Take up the 304561 cable play in the 121246 cable clamp to remove strain from the connector cable leads.

(14) Remove the three 151412 insulators from the base terminal strips by removing the 151630 mounting screws and 2191 lockwashers. Refer to applicable wiring information in NAVSHIPS Manual 94456 and 7220WD Wiring Diagram included in the kit: Remove the spare BL, W-R and BR wires from terminals 3, 4, and 5 of the B upper line terminal strip, respectively. Remove the jumper from between terminals 4 and 5 of the B terminal strip. Remove the L-2-BR and L-1-BK cable leads from terminals 3 and 1, respectively, of the B terminal strip, and move the G-1-W cable lead from terminal 3 to terminal 1, and the C-33-R cable lead from terminal 2 to terminal 3. Tape the five removed cable leads together and position them to the left and rear of the terminal strip mounting bracket.

(15) Replace the 111017 terminal screws from terminals 1 and 3 of the A lower power terminal strip with the two 84082 screws. Wire the 304937 and 304938 cables to the base A, B, and U terminal strips in accordance with 7220WD Wiring Diagram. Secure the ground leads to the B terminal strip cover mounting post (between the post and the terminal strip cover). Tighten all terminal screws securely. Replace the three 151412 terminal strip insulators by means of the 151630 mounting screws and 2191 lockwashers removed in Paragraph (14).

(16) Tie the 304937 and 304938 cables to the base main cable for securement as shown in Figure 5. Connect the 304938 cable to the 179748 connector plug of the 304561 cable at the 309499 bracket. Route the 304937 and 304938 cables down and to the rear of the base 159542 16-point connector receptacle. Utilizing the hole located at the rear of the 159542 connector receptacle, secure the 304937 and 304938 cables to the base using the 121246 cable clamp, 153538 screw, two 7002 flat washers, 2191 lockwasher and 3598 nut as shown in Figure 5 (start the screw and flat washer from the bottom).

(17) Wire the 304937 cable to the 192730 selector magnet driver, and the 179637 and 304938 cables to the 192740 low-level keyer in accordance with 7220WD Wiring Diagram. See Figure 11 for frame ground location.

(18) 192730 Selector Magnet Driver Assembly and 192740 Low-Level Keyer Assembly Mounting

NOTE

Two 304671 brackets are provided for mounting each driver and keyer external to the typing reperforator set. The 304671 brackets contain three mounting flanges to enable either "Tabletop or Shelf" or "Wall" mounting of the driver and keyer. The driver and keyer mounting location is limited to a distance from the typing reperforator set equal to the length of the driver and keyer cable assemblies.

(a) Tabletop or Shelf Mounting of the 192730 Selector Magnet Driver Assembly and 192740 Low-Level Keyer Assembly

1. Insert the flanges of the two 304671 brackets between the mounting flanges and 192727 clamps of the driver or keyer. The 304671 brackets should be positioned with the mounting holes below the driver or keyer. With the 304671 brackets held squarely against and approximately centered with the driver and keyer, secure the brackets to the driver or keyer by means of the driver or keyer mounting stud and screw. See Figure 8.

2. With the lower end of the mounted 304671 brackets held flush against the driver or keyer, use the brackets as a template to scribe the centers of the two mounting holes in each 304671 bracket on the tabletop or shelf. The brackets should be positioned to face the driver or keyer as cover to the rear of the table or shelf. Drill a

0.257 inch diameter hole (F Drill) at each of the four scribed centers.

3. Secure the 304671 brackets to the tabletop or shelf using the four 89305 screws, eight 85559 flat washers, four 2449 lockwashers, and four 92146 nuts as shown in Figure 8.

(b) Wall Mounting of the 192730 Selector Magnet Driver Assembly and 192740 Low-Level Keyer Assembly

1. Insert the flanges of the two 304671 brackets between the mounting flanges and 192727 clamps of the driver or keyer. The 304671 brackets should be positioned with the mounting holes located toward the driver or keyer ac cover. Position the 304671 brackets until the leading edge of the bracket mounting flange is flush with the forward edge of the driver or keyer mounting flange as shown in Figure 9. With the 304671 brackets held squarely against the driver or keyer, secure the brackets to the driver or keyer by means of the driver or keyer mounting stud and screw. See Figure 9.

2. With the lower end of the 304671 brackets held flush against the driver or keyer, use the brackets as a template to scribe the centers of the two mounting holes in each 304671 bracket on the wall. Drill a 0.257 inch diameter hole (F Drill) at each of the four scribed centers.

3. Secure the 304671 brackets to the wall using the four 89305 screws, eight 85559 flat washers, four 2449 lockwashers, and four 92146 nuts as shown in Figure 9.

(19) Remount the keyboard base on the cover base plate assembly using the four mounting screws removed in Paragraph (4).

(20) Remount the typing reperforator unit on the keyboard base using the mounting hardware removed in Paragraph (3). Connect the keyboard connector plug (161239) to the typing reperforator connector receptacle (161238); secure by means of the two receptacle latches.

(21) Connect and securely lock the 159541 16-point connector plug to its mating receptacle on the keyboard base. Replace the cover on the typing reperforator set.

(22) All sets must be connected to office ground to insure proper suppression of radio-frequency interference.

(23) Navy Only - Remove backing from the 310148 identification plate and apply plate (on clean surface) below the present overall set plate.

b. 179616 MODIFICATION KIT FOR TT-192/UG, TT-192A/UG OR TT-274/UG SET

(1) The 179616 modification kit is wired for 60 milliamperere operation as shipped from the factory. For 20 milliamperere operation change the strapping as follows before installation of the 192730 selector magnet driver:

(a) Remove the circuit card from the assembly by removing the four cover mounting screws and the circuit card nut. The driver circuit card is viewed with the power resistors on top of the unit toward the observer.

(b) Change strapping as shown in Figure 1. Replace the circuit card, circuit card nut, cover, and the four cover mounting screws.

NOTE

Regardless of current input, the selector magnet driver output to the selector magnets should always be 60 milliamperes.

(2) Remove the cover from the typing reperforator set.

(3) The typing reperforator selector magnets must be wired for 60 milliamperere operation. If necessary, change selector magnet wiring in accordance with applicable wiring information in NAVSHIPS 94456.

(4) For LRB8 Base Only - TT-192/UG or TT-274/UG Set

(a) Disconnect the 159541 16-point connector plug from its mating receptacle on the base to remove power from the unit.

(b) Remove the two 151412 insulator covers from the upper and lower terminal blocks by removing the four 151630 mounting screws and 2191 lockwashers.

(c) Remove the two 151637 screws and 2191 lockwashers that secure the 159542 16-point connector receptacle to the 159589 mounting bracket. Unsolder the red and blue cable leads from terminals 8 and 16 of the "F" 16-point connector receptacle. Refer to 7194WD Wiring Diagram included in the kit. Pull the red and blue wires out from underneath the cable lacing down to the cable junction of wires leading to the DH lower terminal block. If necessary, cut the cable lacing. Carefully trim the ends of the red and blue wires and add the two 82474 terminals to the ends of the two wires. See Figure 6.

(d) Insert the two 155750 insulating sleeves over the 153622 and 153803 jumpers. Solder the purple 153622 jumper to terminal 8 and the slate 153803 jumper to terminal 16 of the 159542 connector receptacle. Refer to 7194WD Wiring Diagram. Slip the 155750 insulating sleeves over the two soldered connections and remount the 159542 connector receptacle on the 159589 bracket using the two 151637 screws and 2191 lockwashers removed in Paragraph (c).

(e) Remove and tape the W-BL wire from terminal DG2 of the upper terminal block. Move the W-O wire from terminal DG8 to terminal DG7.

(f) Wire the 304685 selector magnet driver cable, 153622 and 153803 jumpers, and the red and blue base cable leads to the DG and DH terminal blocks in accordance with 7194WD Wiring Diagram. Form the purple and slate leads to avoid interference with the 161873 resistor on the DG upper terminal block. Secure the green ground lead to the DG terminal cover mounting post (this lead is to be placed between the post and the cover). Tie the cable leads to the 162574 cable in two places. See Figure 6 for cable routing and securement. Tighten all terminal screws securely.

(g) Replace the two 151412 insulator covers on the terminal blocks using the four 151630 mounting screws and 2191 lockwashers removed in Paragraph (b).

(h) Secure the 304685 cable in the 159931 cable clamp by means of the 159932 keeper.

(i) Make certain that the 161239 36-point connector plug is connected to the 161238 typing reperforator connector receptacle and secured by means of the two receptacle latches.

(j) Wire the 304685 cable to the 192730 selector magnet driver in accordance with 7194WD Wiring Diagram. See Figure 11 for frame ground location.

(k) Connect and securely lock the 159541 16-point connector plug to its mating receptacle on the base. Replace the cover on the typing reperforator set.

(5) For LRB31 Base Only - TT-192A/UG Set

(a) Unplug the typing reperforator set from its power source and remove the 151412 insulator cover from the upper terminal block by removing the two 151630 mounting screws and 2191 lockwashers.

(b) Move the red wire from terminal DG2 of the lower terminal block to terminal DG3 and the blue wire from terminal DG8 to terminal DG6. Refer to 7192WD Wiring Diagram included in the kit.

(c) Route the 304685 selector magnet driver cable to the rear of the two terminal blocks and wire the 304685 cable to the DH upper and DG lower terminal blocks in accordance with 7192WD Wiring Diagram. Tighten all terminal screws securely. Replace the 151412 insulator cover on the upper terminal block using the two 151630 screws and 2191 lockwashers removed in Paragraph (a).

(d) Remove the 3598 nut, 2191 lockwasher, and 125015 flat washer that secure the 121246 and 121247 cable clamps to the rear of the terminal block assemblies. Discard the 121247 cable clamp and secure the ac power and 304685 cables with the 121248.

cable clamp. Secure the 121246 and 121248 cable clamps using the 3598 nut, 2191 lockwasher, and 125015 flat washer. See Figure 7.

(e) Make certain that the 161239 36-point connector plug is connected to the 161238 typing reperforator connector receptacle and secured by means of the two receptacle latches.

(f) Wire the 304685 cable to the 192730 selector magnet driver in accordance with 7192WD Wiring Diagram. See Figure 11 for frame ground location.

(g) All sets must be connected to office ground to insure proper suppression of radio-frequency interference.

(6) 192730 Selector Magnet Driver Assembly Mounting - Refer to Paragraph 3.a.(18).

(7) Replace the cover on the typing reperforator set.

(8) Navy Only - Remove backing from the 310149 identification plate and apply plate (on clean surface) below the present overall set plate.

4. ADJUSTMENTS - SIGNAL CONTACTS (179615 kit only) - The clearance between the marking and spacing contacts and the toggle should be equal within 0.001 inch when the contacts are in their extreme open position, determined by rotating the cam after the "Y" key has been depressed. To adjust, loosen the two mounting screws on the signal generator front plate to friction tightness, then move the entire contact box assembly left or right by means of the eccentric located between the two mounting screws. Tighten the mounting screws after obtaining equalized contact clearance.

CAUTION

The signal generator should not be electrically adjusted in accordance with standardized signal generator adjustment information unless there is an intermediate device available to key the signal test set from the 3 volt 70 microampere signal generator circuit.

5. SERVICING

a. GENERAL

(1) This servicing section covers trouble shooting of the 179615 modification kit when installed in Teletypewriter Typing Reperforator Set TT-253/UG, and of the 179616 modification kit when installed in Teletypewriter Typing Reperforator Set TT-192/UG, TT-192A/UG, or TT-274/UG.

(2) It is suggested that field servicing be limited to replacement of a complete unit (192730 selector magnet driver or 192740 low-level keyer) only, and that repairs of this unit should not be attempted in the field. Repair service should be made at a maintenance center which is properly equipped and should be handled only by personnel who are familiar with transistor circuitry and with radio-frequency interference test equipment.

(3) Field tests and replacement of units can be handled by personnel familiar with standard Teletype equipment.

b. 192730 SELECTOR MAGNET DRIVER OR 192740 LOW-LEVEL KEYER - REMOVAL AND REPLACEMENT

(1) Removal - Loosen the driver or keyer mounting screw and stud and disengage the driver or keyer from the 304671 brackets. See Figure 8 or 9 as applicable.

(2) Replacement

(a) For tabletop or shelf mounted 304671 brackets, install the driver or keyer on the brackets with the ac cover toward the rear of the table or shelf. With the driver or keyer approximately centered on the brackets, tighten the driver or keyer mounting screw and stud. See Figure 8.

(b) For wall mounted 304671 brackets, install the driver or keyer on the brackets with the ac cover toward the wall. Position the driver or keyer on the brackets until the forward edges of the driver or keyer mounting flanges are aligned with the forward edge of the bracket mounting flanges and tighten the driver or keyer mounting screw and stud. See Figure 9.

c. SIGNAL GENERATOR CONTACTS (FOR 179615 KIT ONLY) - Errors in the signal may be an indication that the signal generator contacts require cleaning in order to remove any accumulation of dirt, oil, etc. Burnishers, files, etc., should never be used as they will remove the gold from the gold-plated contacts. The contacts should be cleaned with twill jean cloth (KS2423), as follows: Open the contacts; drop a strip of twill jean cloth between them; close the contacts; draw the cloth part way through; reopen the contacts and withdraw the cloth. This procedure prevents small fibers, from lodging between the contacts.

CAUTION

Also see the portion of Paragraph 1.j. pertaining to the signal generator contacts.

d. STORAGE TEMPERATURE - Temperature should not exceed +85C (185F).

e. FIELD TESTS

(1) Special Equipment Required - An accurate voltmeter and milliammeter (2 per cent).

(2) Checks for Locating Trouble

(a) For 179615 Kit - Typing Reperforator Running Open

1. Check polarity of incoming signal line. At the keyboard terminal strips, terminal B1 is positive and terminal B2 is negative.

2. Check current in signal line. The signal line current should be 60 ± 10 per cent ma. or 20 ± 10 per cent ma. (Check for proper driver or keyer strapping for either current.)

3. Make certain that all connector plugs are firmly seated in their respective connector receptacles.

4. Check voltage across terminals B1 and B4. If a voltage drop is present, check line test key.

5. Measure voltage drop across the keyer at terminals B2 (negative) and B7 (positive) with the keyboard in the stopped position (wiring must conform). If voltage drop is more than 5 volts, perform the following checks:

a. Remove the cover from the signal generator contact box assembly. With the keyboard in the stopped position, check voltage across the marking contact in accordance with Figure 10 (A and I2). If a voltage drop is present, readjust the signal generator contacts. If no voltage is present, make a voltage check across the 179643 filter network. If voltage across the network does not meet requirements, replace the network.

b. If the filter network meets requirements, check the wiring of the keyer. If the wiring is correct, replace the keyer.

6. Check voltage drop across the driver at terminals B4 (positive) and B7 (negative). Check the wiring of the driver. If the wiring is correct, replace the driver.

(b) For 179615 Kit - Typing Reperforator not being Keyed by Keyboard - With the keyboard in the stopped position, depress the signal line break key or disconnect one side of the signal line. If the typing reperforator runs open, check the keyer as outlined below. If the typing reperforator does not run open replace the driver. To check the keyer perform the following:

Remove the cover of the signal generator contact box assembly. With the signal generator contacts in the spacing position, check voltage across the marking contact in accordance with Figure 10 (A and I2). If a voltage drop of 3 volts is not present, readjust the contacts. Check the voltage across terminals 01 and 02 when the contacts are in the spacing position. If a voltage drop of 5 volts is not present, replace the 179643 filter network. If the network and contacts meet requirements, replace the keyer.

(c) For 179615 Kit - Typing Reperforator Being Keyed by Keyboard but Garbling Message

1. Check signal line current.
2. Check signal generator contacts for accumulation of dirt, oil, etc.
3. Check adjustments of signal generator contacts.
4. Check range scale adjustment on selector of receiving unit.

(d) For 179615 Kit - Replace the signal generator contact box cover.

(e) For 179616 Kit - Typing Reperforator Running Open

1. Check polarity of incoming signal line. On LRB8 base, terminal DG1 is positive and terminal DG2 is negative. On LRB31 base, terminal DG2 is positive and terminal DG8 is negative.

2. Check current in signal line. The signal line current should be 60 ± 10 per cent ma. or 20 ± 10 per cent ma. (Check for proper driver strapping for either current.)

3. Make certain that all connector plugs are firmly seated in their respective connector receptacles.

4. Check the wiring of the driver and the reperforator base terminal blocks. On the LRB8 base, check terminal circuitry F8 to DG1 and F16 to DG2 for base connector receptacle solder connection continuity. If wiring is correct, replace the driver.

(f) For 179616 Kit - Typing Reperforator Garbling Message - Check range scale adjustment on selector of typing unit.

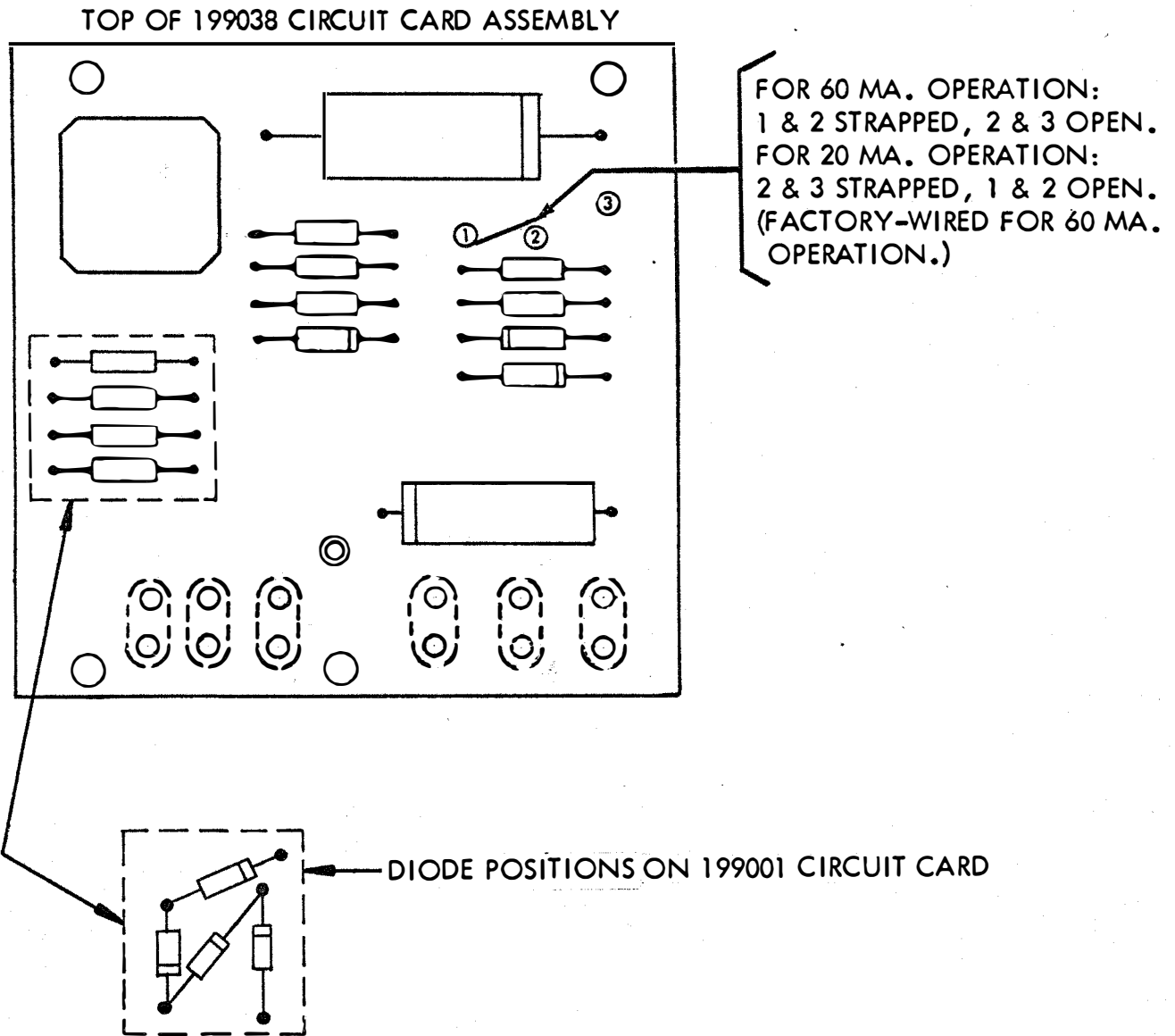

192730 SELECTOR MAGNET DRIVER SIGNAL LINE WIRING OPTIONS

FIGURE 1

50252S

TOP OF 199003 CIRCUIT CARD ASSEMBLY

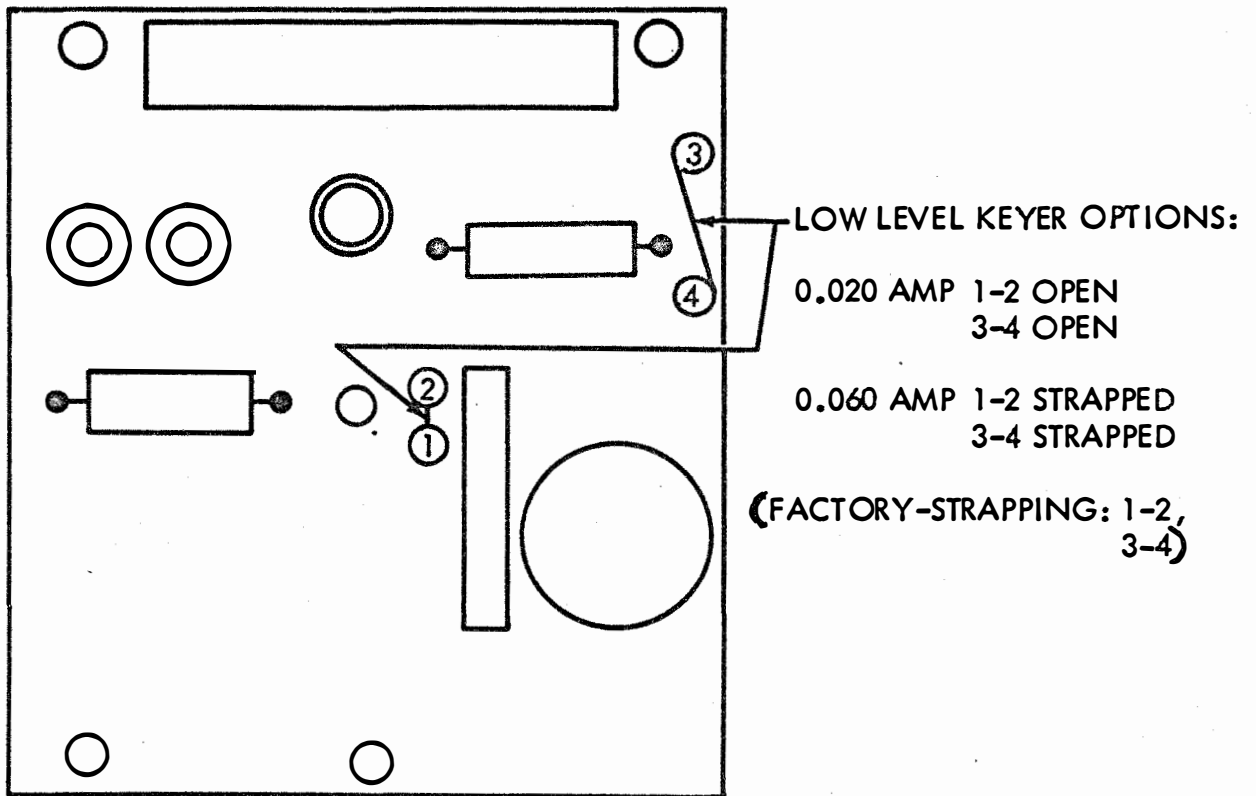

192740 LOW-LEVEL KEYSER SIGNAL LINE WIRING OPTIONS

FIGURE 2

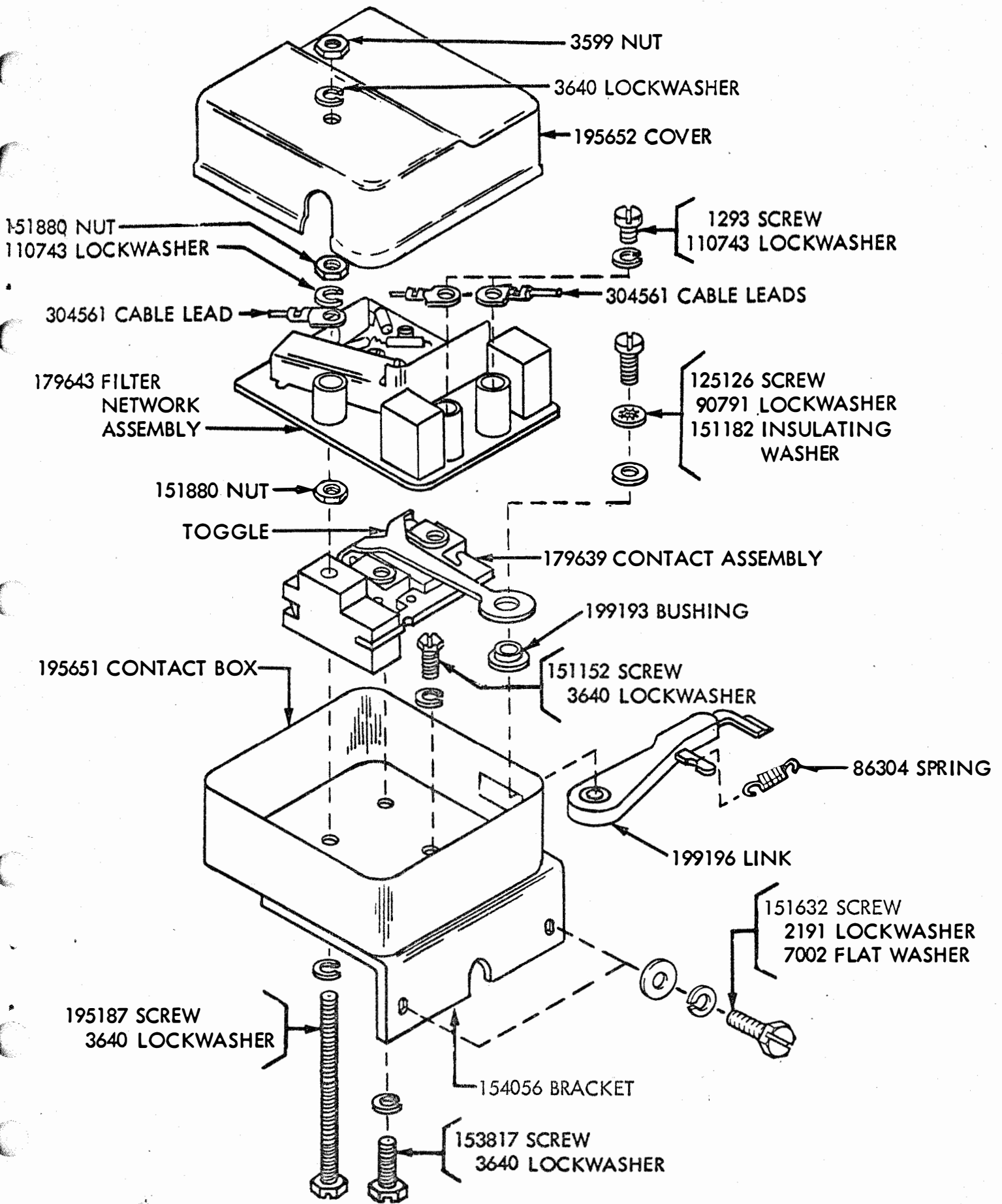

SIGNAL GENERATOR COMPONENTS

FIGURE 3

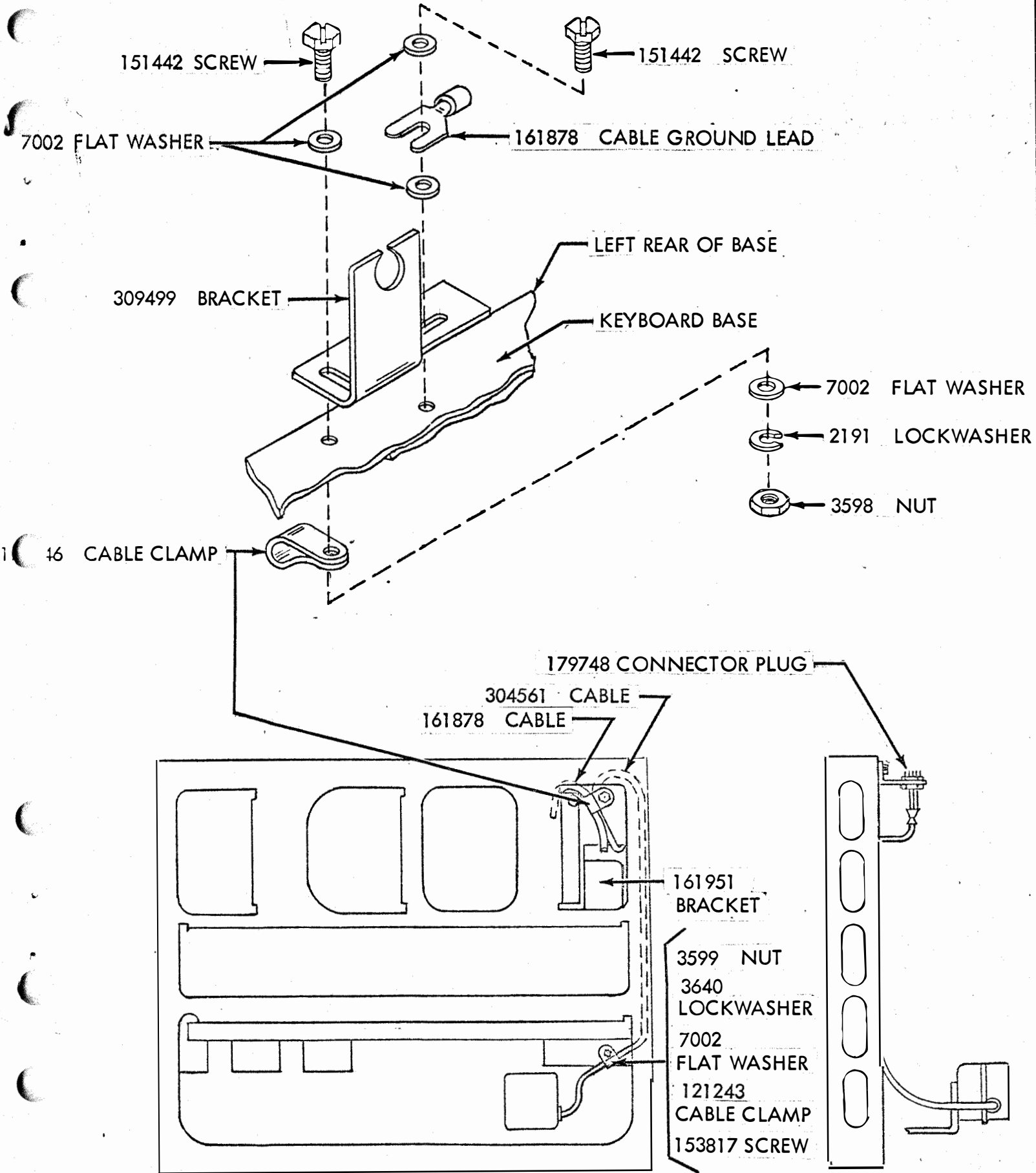

CABLE ROUTING AND SECUREMENT - FOR TT-253/UG SET

FIGURE 4 (ALSO SEE FIGURE 5)

CABLE ROUTING AND SECUREMENT - FOR TT-253/UG SET
FIGURE 5 (ALSO SEE FIGURE 4)

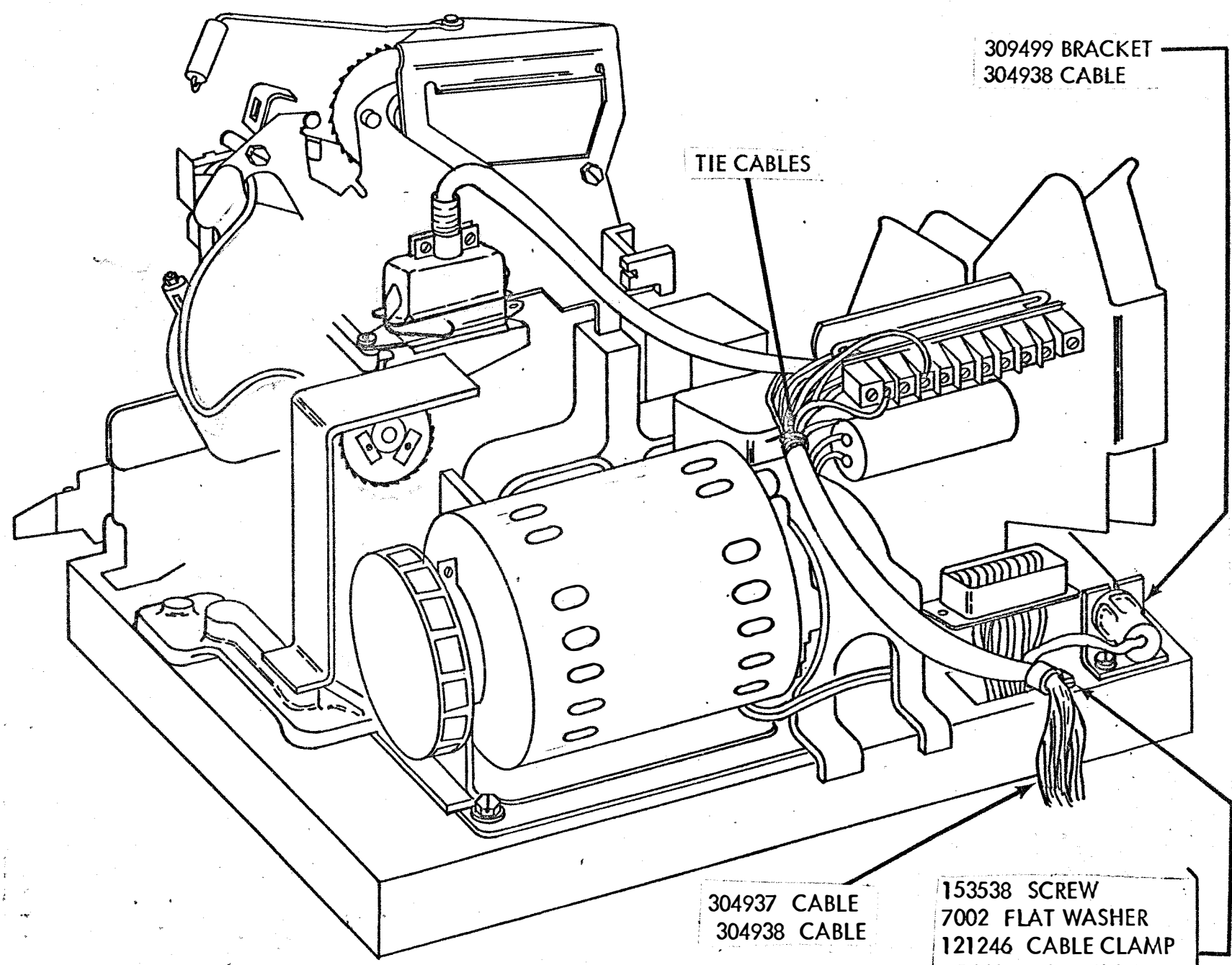

309499 BRACKET
304938 CABLE

TIE CABLES

304937 CABLE
304938 CABLE

153538 SCREW
7002 FLAT WASHER
121246 CABLE CLAMP
7002 FLAT WASHER
2191 LOCKWASHER
3598 NUT

FIGURE 6

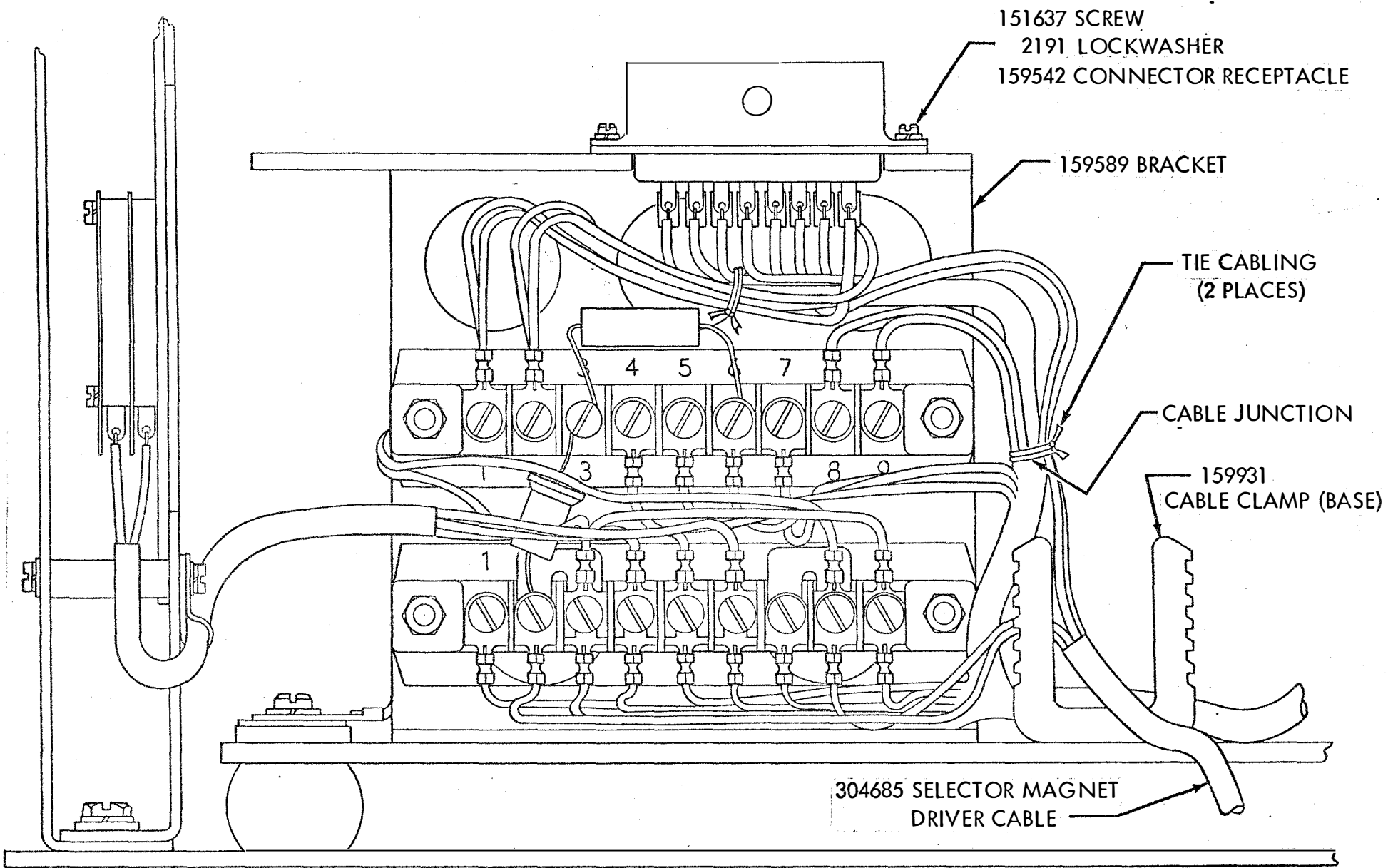

151637 SCREW
 2191 LOCKWASHER
 159542 CONNECTOR RECEPTACLE

159589 BRACKET

TIE CABLING
 (2 PLACES)

CABLE JUNCTION

159931
 CABLE CLAMP (BASE)

304685 SELECTOR MAGNET
 DRIVER CABLE

50252S

LRB8 BASE CABLE ROUTING AND SECUREMENT - FOR TT-192/UG OR TT-274/UG SET

FIGURE 7

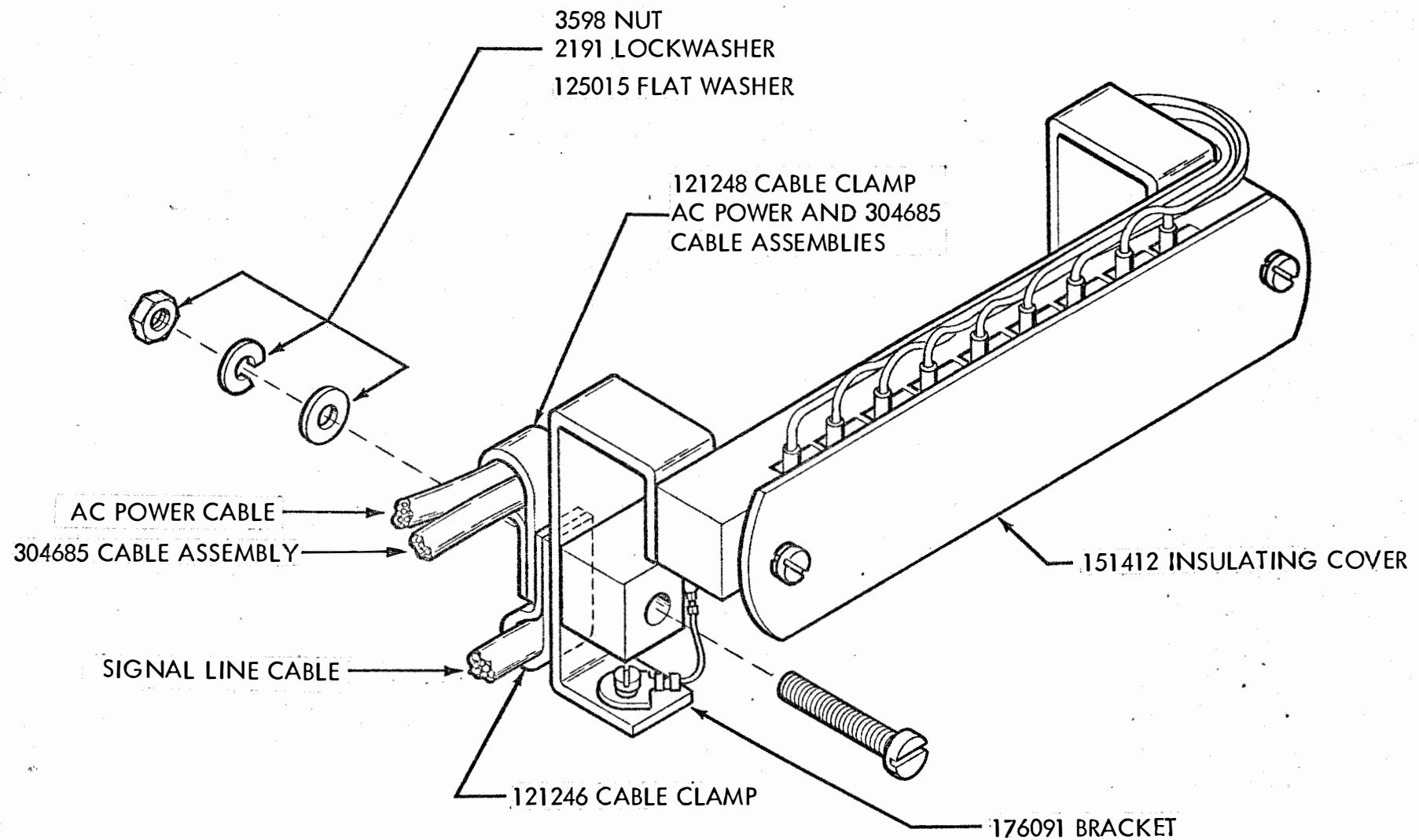

LRB31 BASE CABLE SECUREMENT - FOR TT-192A/UG SET

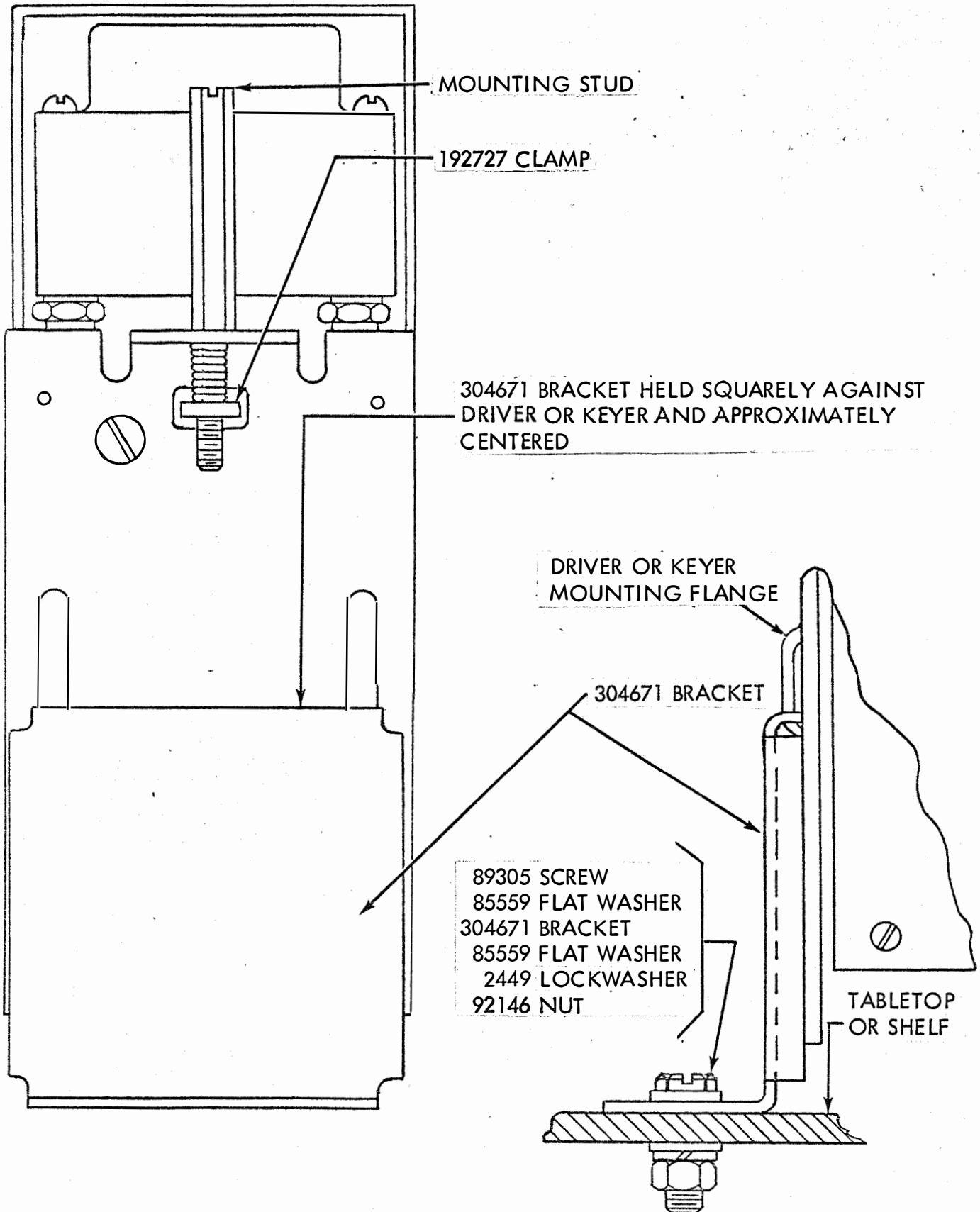

TABLETOP OR SHELF MOUNTING OF 192730 SELECTOR MAGNET DRIVER OR 192740 LOW-LEVEL KEYER

FIGURE 8

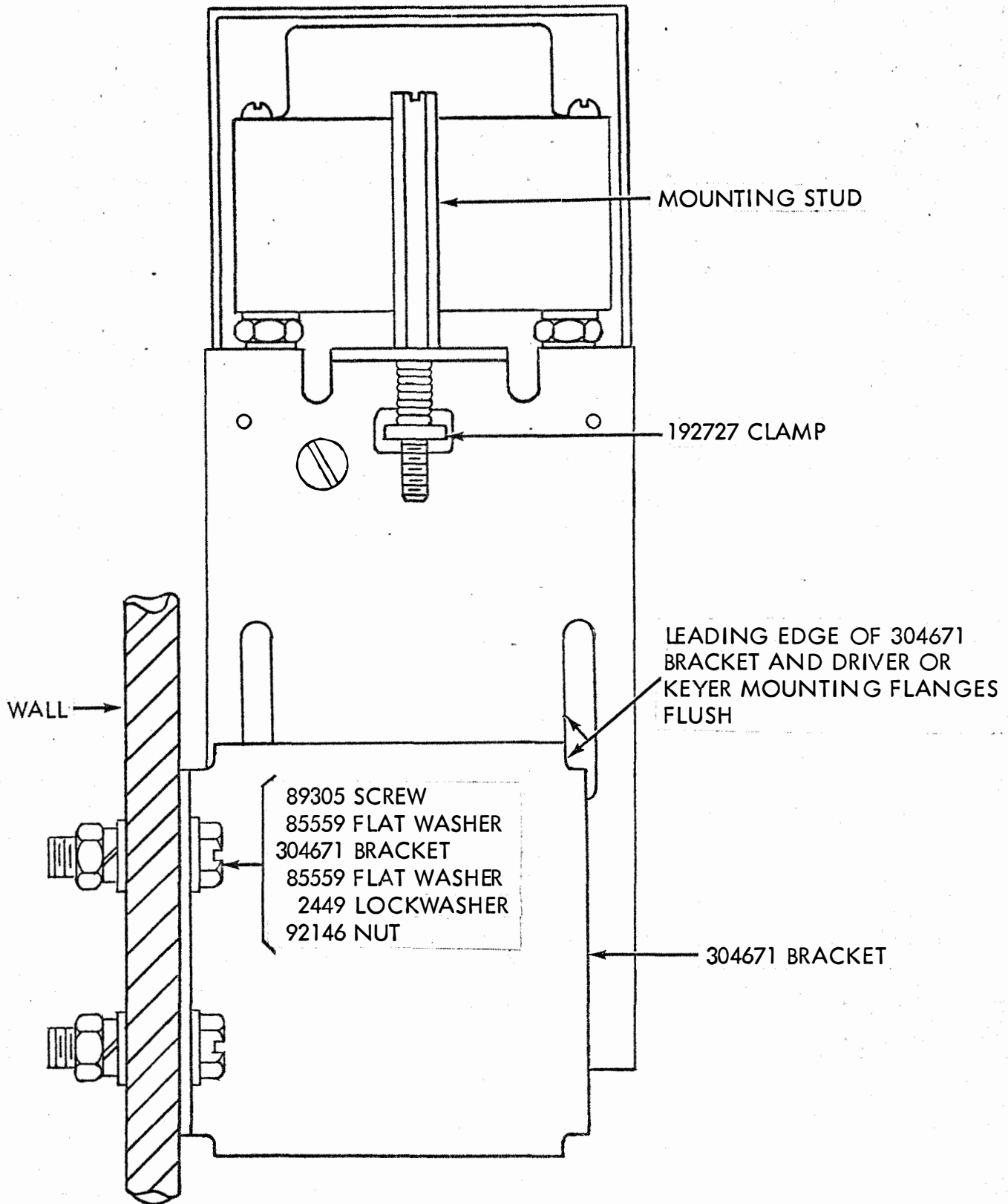

WALL MOUNTING OF 192730 SELECTOR MAGNET DRIVER OR
 192740 LOW-LEVEL KEYER

FIGURE 9

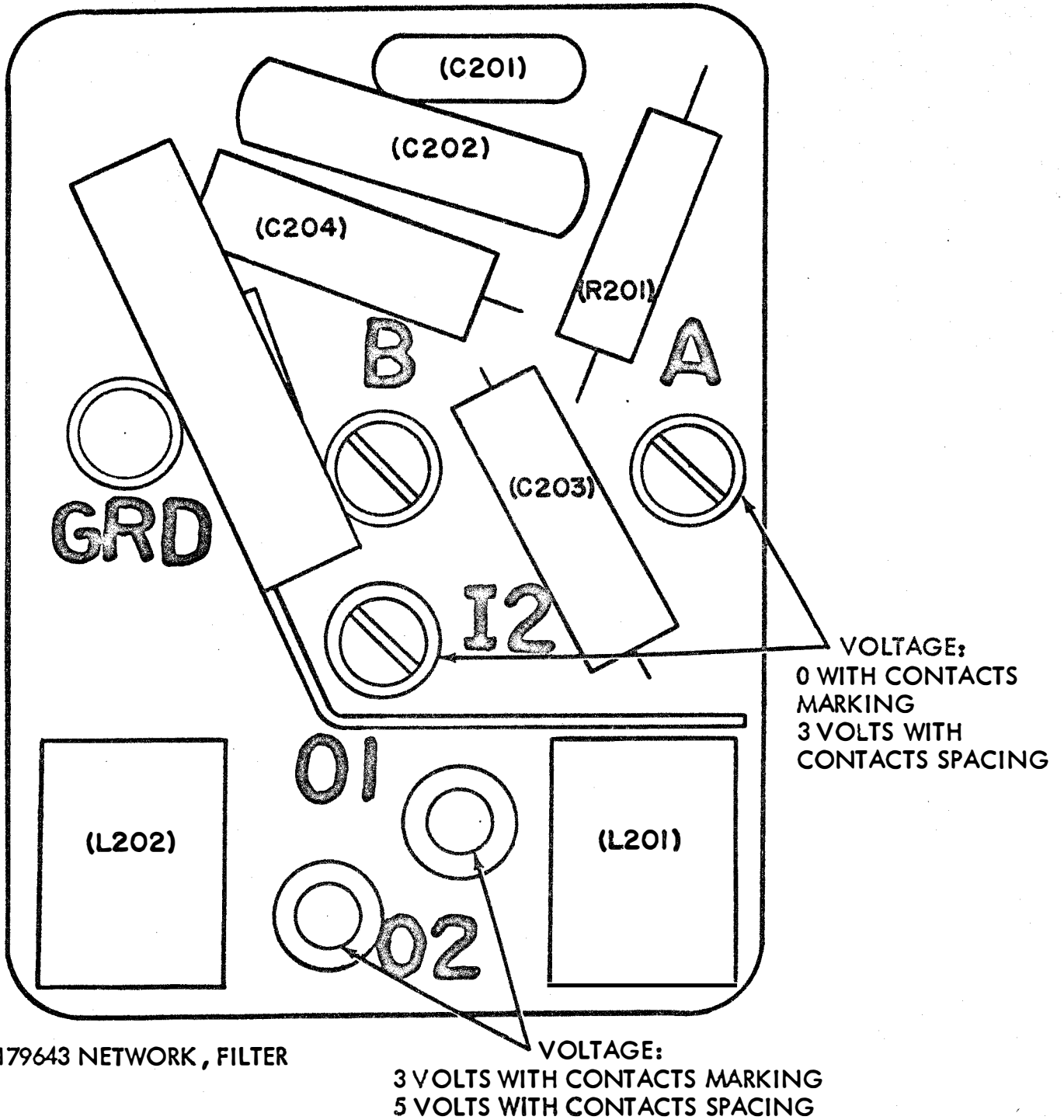

179643 NETWORK, FILTER

FIGURE 10

DRIVER — 304685 CABLE ASSEMBLY (179616 KIT)
DRIVER — 304937 CABLE ASSEMBLY (179615 KIT)
KEYER — 304938 CABLE ASSEMBLY (179615 KIT)

DRIVER — GREEN WIRE
KEYER — COPPER BRAID

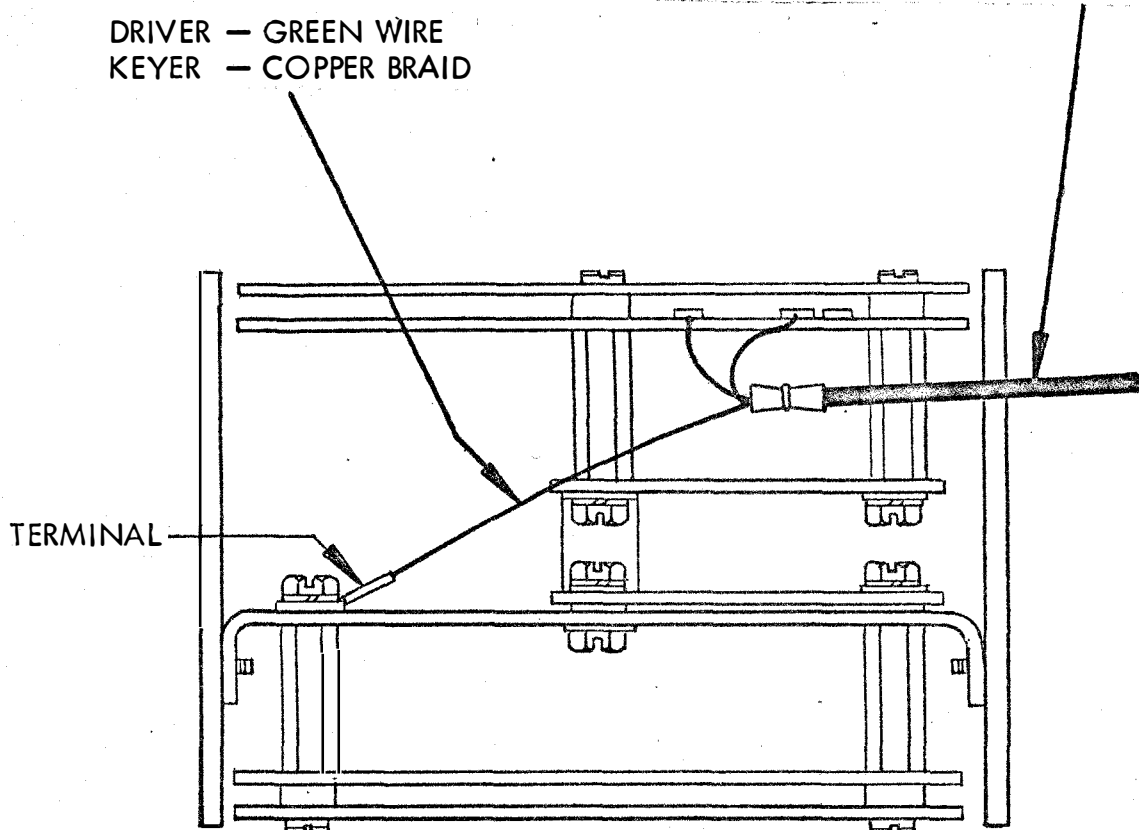

PARTIAL BOTTOM VIEW OF SELECTOR MAGNET DRIVER OR LOW-LEVEL KEYER
SHOWING FRAME GROUNDING LOCATION

FIGURE 11