

# DIGITAL

# Journal

Formerly published as the  
RTTY Journal, and the  
RTTY/Digital Journal

The Premier Source of  
Digital News and Knowledge  
Since 1953

Published by the International Digital Radio Association • Volume 44, Number 8 • August 1996 • \$3.50

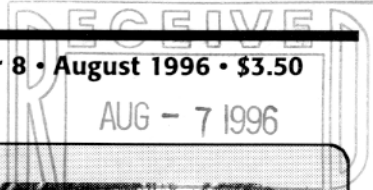

## IN THIS ISSUE

President's Corner .....	3
Digital Images .....	4
International Scene .....	7
Across the Pond .....	8
DX News .....	11
Contesting .....	13
Mighty Macros .....	15
Low Bands & RTTY .....	17
The Contest Chair .....	19
Digital Satellites .....	22
'95 CQ/DJ WW Results ....	26
The Last Word .....	27
Classifieds .....	29
Software Store .....	30

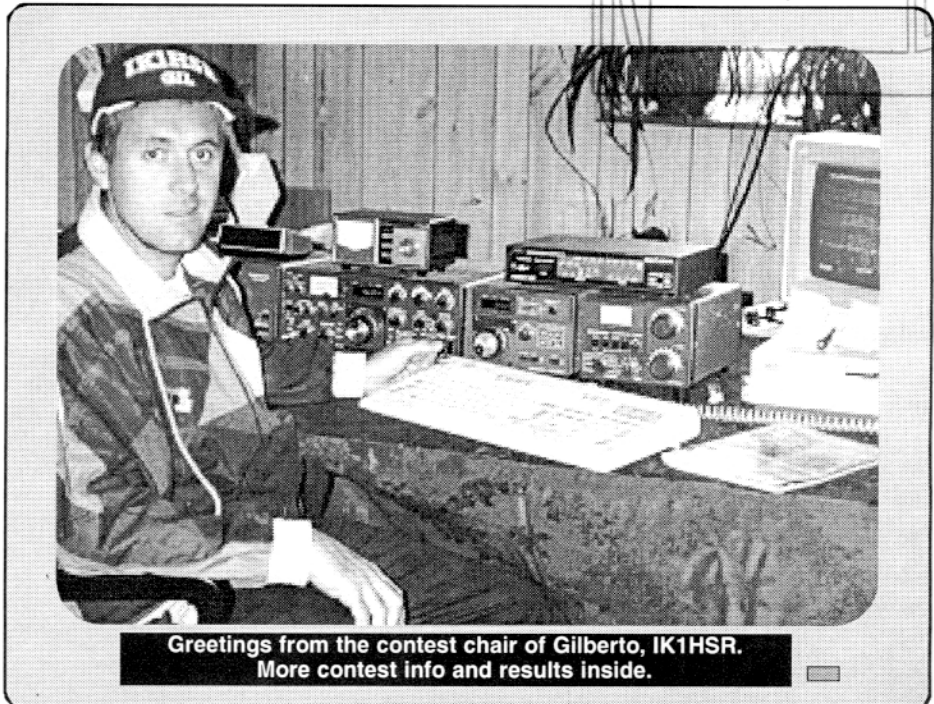

Greetings from the contest chair of Gilberto, IK1HSR.  
More contest info and results inside.



Digital Journal (USPS 391-850) is published monthly, for \$25 per year by the International Digital Radio Association, 1908 Howell Branch Road, Winter Park, FL 32792. Second-Class Postage paid Winter Park, FL and additional entry offices. Postmaster: Send address changes to Digital Journal, P.O. Box 2550, Goldenrod, FL 32733-2550.



International Digital Radio Association  
P.O. Box 2550  
Goldenrod, FL 32733-2550

SECOND CLASS  
POSTAGE PAID  
GOLDENROD, FL  
32733-2550

Copyright 1996  
IDRA • All Rights Reserved  
Permission for reproduction or dissemination of any of the material provided herein must be obtained in writing from the Publisher.

|||||  
--Expiration: COMP/ \*  
BILL HENRY  
HAL COMMUNICATIONS, INC  
PO Box 365  
Urbana IL 61803 USA  
=====

atdata, internet, by/ichu

# DIGITAL Journal

Published by the International Digital Radio Association  
PO Box 2550, Goldenrod, FL 32733-2550  
Tel (407) 677-7000 • FAX (407) 671-0194

**INTERNET:**  
**WWW Site at:** <http://www.iea.com/~adrs>  
**FTP Site at:** <ftp.iea.com/public/adrs>  
**Internet/E-mail:** [adrs@iea.com](mailto:adrs@iea.com)  
**Editor's Desk:** <http://www.n2hos.com/digital/>

### Editor

Jim Mortensen, N2HOS : (914) 276-1058 / FAX (914) 276-1059

### Associate Editors

Neal Campbell, AB4MJ/ON9CNC • Don Hill, AA5AU

### General Manager

Tom Arvo, WA8DXD : Tel/FAX same as IDRA

### Directors/Officers

Paul Richter, W4ZB (President)  
Jim Mortensen, N2HOS (Vice President)  
Al Matlick, W2TKU (Secretary)  
Glen Vinson, W6OTC (Treasurer)

Jules Freundlich, W2JGR • Joel Kandel, KI4T • Ron Stailey, AB5KD  
Peter Schulze, TY1PS • Barry Garratt, VE3CDX

### Editorial Staff

Bob Boyd, W1VXV • Neil Campbell, ON9CNC • Jules Freundlich, W2JGR  
Steve Holton, N2QCA • Glenn Vinson, W6OTC  
Richard Lawton, N6GG • Crawford Mackeand, WA3ZKZ  
Doug Hall, KF4KL • Ron Stailey, AB5KD • Jim Berner, K8OSF  
Bob Lewis, AA4PB • Dave Wolf, W05H • Betsy Townsend, WV7Y  
Paul Richter, W4ZB • Peter Lumb, G3IRM • Fred Salzwedel, DK4ZC  
Hal Blegen, WA7EGA • Roy Gould, KT1N • Don Hill, AA5AU  
Dave Medley, KI6QE • Tom Housworth, N3PGG

## Membership Rates & General Info

Rates =	1 Year	2 Years	3 Years*
No. America	\$25	\$47	\$68
1st Class US	\$32	\$60	\$85
DX - Surface	\$32	\$60	\$85
DX - Airmail	\$42	\$78	\$114

**\*Deduct \$2 more if a gift subscription is added to the total**

Surface mail is not recommended to the former USSR Republics, Asia, Oceania or the Middle East. Payment must be in US funds. Allow 6 weeks on new subscriptions. Visa/MasterCard accepted. Make all remittances payable to the International Digital Radio Association.

The principal goal of the IDRA is to advance digital technology as it applies to amateur radio and promote the wisest use of the digital portion of the spectrum. Being a member makes you a partner in advancing these digital goals. IDRA is a not-for-profit corporation and contributions to the Society are deductible for income tax purposes to the extent allowable under the tax laws of the United States.

### Have you checked your mailing label lately?

If the *Expiration 08/96* appears next to your name, it means your IDRA membership, and subscription to the *Digital Journal*, expires with this issue.

To keep your membership, and all the latest digital news coming your way, just fill out the coupon on page 29 and mail it -- **Today!**

# DSP4100

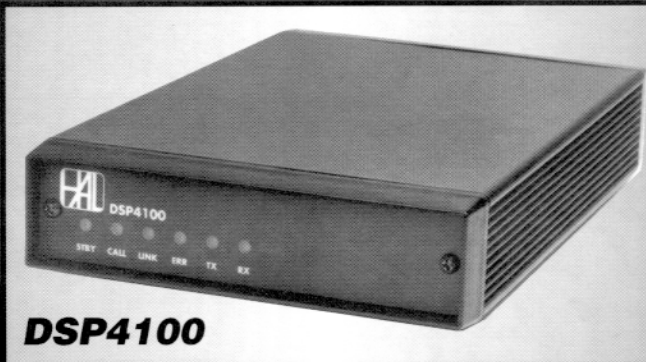

**DSP4100**

**HF Radio DSP Modem**  
**STAND-ALONE**  
**COMPACT**  
**PORTABLE**  
**HIGH PERFORMANCE**

**-- all the features you've been asking for in a CLOVER DSP Modem --**

At long last, the proven HAL DSP Modem architecture, modes, and software are available for applications that cannot use plug-in PC cards. While the DSP4100 closely follows the concepts of the PCI-4000, now you get CLOVER-II and high-performance TOR, Pactor, and RTTY in a stand-alone DSP modem. Requiring only 0.25A from a 12V battery, the 2.75 lb DSP4100 will go anywhere you can take your LAP-TOP PC and transceiver. Software changes are easily made in the field. Just pick-up new software from HAL and upload it to the DSP4100 via the serial port for storage in non-volatile FLASH RAM. A 2nd RS-232 port is included for customized systems. Call HAL now for complete details.



**HAL Communications Corp.**

P.O. Box 365, Urbana, IL 61801 USA

Phone (217) 367-7373 Fax (217) 367-1701 E-Mail [halcomm@prairienet.org](mailto:halcomm@prairienet.org)



# President's Corner

## A view from the top

by Paul S. Richter, W4ZB

P.O. Box 19190 • Washington, DC 20036-9190 / CIS 70743,3517

On my flight back to Washington, D.C. from the Dayton Hamvention in May, I found myself by chance sitting next to a distinguished old timer, John Kelleher, W4ZC. (The flight attendant assured me the hams had not been seated by callsign sequence.) Once we began talking about current digital modes on HF, he described how he had been involved in commercial HF CW (Morse code) operations in the 1930s and his recollections confirmed that CW was, indeed, the original HF digital data mode even though much of the "automation" at the time involved human operators exercising their mental capacities, assisted by electromechanical devices.

Single frequency transatlantic commercial HF CW links in the late 1930's often operated at speeds as high as 300 wpm when propagation conditions were good according to W4ZC. The messages to be sent from the transmitting end would be punched onto paper tapes which could be spliced together and fed through a tape reader at speeds up to 300 wpm to generate the Morse keying for an HF transmitter. The rate at which the tape was fed through the Morse tape reader was manually adjusted based upon the link conditions. At the receiving end, the received audio was fed to a pen register which printed a representation of the CW signal onto a continuous strip of paper tape. The printed tape would be cut into segments which were then handed to transcribers who would decode the Morse code

representations on the tape segments and prepare printed copy manually using typewriters. Just a few years later very high speed HF CW circuits of this type were replaced by HF RTTY circuits which required few operators (and no transcribers) at the receiving end.

I thought that many of you who, like me, don't go back quite that far, would be interested in hearing how high speed digital data transfers were accomplished in the old days. These old approaches which worked very effectively for a time and then quickly became obsolete have now almost been lost to history!

We, of course, now live in an age in which everything technical is continuing to change very rapidly. I recently visited (in cyberspace) Digital Equipment Corporation's excellent Internet site search facility at <http://www.altavista.digital.com>. While there, I learned that the IDRA's WWW site, now only 18 months old, currently has hyperlinks pointing to it from more than 300 other WWW sites, many of which are outside of North America. No reason at all any longer to question why the acronym WWW stands for the World Wide Web.

As we approach the printing deadline, I have just picked up a rumor that Ron Stailey, AB5KD, has finally gotten full Internet access using a program that runs under Windows. With his great energy and enthusiasm, this hopefully means we can all look for major improvements in the IDRA WWW pages relating to all aspects of RTTY contesting before long - perhaps after the next RTTY contest is over!

The other new members of IDRA's Board and of the Digital Journal editorial staff mentioned last month all have kept their respective noses to the grindstone. A lot of

(Cont'd on page 21)

## The most powerful DSP-Modem, and much more...

# SCS PTC-II

The Multimode-Multiport-Controller with PACTOR-II, the fastest digital mode on HF!

### The PTC-II-Hardware:

- Three simultaneously available communications ports: HF and up to two VHF/UHF Packet ports.
- Separate transceiver control port for remote operation of Icom, Kenwood and Yaesu equipment.
- True 32-bit system with the Motorola RISC processor 68360 as CPU, clocked at 25 MHz.
- 16-bit Motorola DSP 56156 clocked at up to 60 MHz (computing power: 30 MIPS).
- Expandable to 2 MB of static and 32 MB of dynamic RAM, firmware stored in flash memory.
- Modem tones programmable in 1 Hz steps.
- All digital modes can be implemented.
- All advantages of the PTCplus are also included.

For more details on the PTC-II and PACTOR-II see the Internet pages '[HTTP://WWW.SCS-PTC.COM](http://WWW.SCS-PTC.COM)'!  
Basic PTC-II with 512k static RAM: 950 US\$, Airmailing: 35 US\$ - VISA and MASTER cards are accepted!

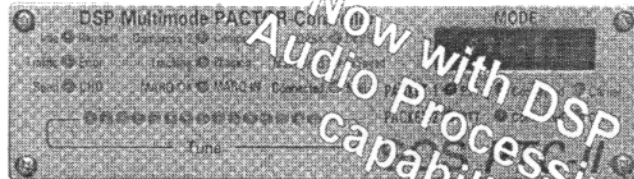

### The PACTOR-II-Mode:

- In good conditions up to 30 times faster than AMTOR, up to 6 times faster than PACTOR-I.
- Most robust digital mode. Maintains links in conditions with a signal to noise ratio down to minus 18 dB!
- Best bandwidth efficiency: Even using the fastest mode, PACTOR-II requires less than 500 Hz (at minus 50 dB).
- Automatic frequency tracking allows the same tolerance when connecting as with PACTOR-I (+/- 80 Hz).
- Newly developed on-line data compression system (PMC) reduces the data by about factor 2.
- Fully backwards compatible with all known PACTOR-I implementations, including automatic switching.
- Utilizing of the latest coding technology.

# SCS - Special Communications Systems

Roentgenstrasse 36, D - 63454 Hanau, Germany, Phone/Facsimile: +49 6181 23368

# Digital Images for Digital Mode Communications

## Part 3

By Paul S. Richter, W4ZB

P.O. Box 19190 • Washington, DC 20036-9190 / CIS: 70743,3517

## INTRODUCTION

This is the third and final part of the Digital Image series. We present further information about how to use software and specialized hardware to get particular images into digital image files, and then how to edit, enhance and modify digital images using readily available software. Next we give an example of how an actual digital image was prepared and sent (over the Internet). Finally, we give specific information about how to send 8-bit binary digital image files over connected Clover and FACTOR HF radio links. Throughout, we provide specific information about how to locate and obtain pertinent shareware and other specific information using Internet resources.

## SCREEN CAPTURE SOFTWARE

One of the easiest methods of getting a particular image into an digital image file is to use a screen capture software to capture into a digital image file a computer screen image created by other application software. The other application software can be anything which produces a graphics image on the computer display screen which may, of course, also include text.

A wide variety of screen capture software is available. Typically, screen capture software is first loaded so it runs in the background (whether as a background Windows application or as a TSR program under DOS); when the user is ready to capture a particular image on the computer display created by another application program, the user activates a predetermined "hot key" sequence. Depending upon the particular capture software, then either the entire screen or some user selectable portion of the screen image is then captured and saved in a digital image file.

My personal preference for screen capture software is the commercial HiJaak Pro software which works extremely well under both DOS and Windows. I used that software to capture the MATLAB generated sunspot graphic printed in Part II of this series. More information about the HiJaak Pro suite of image display, capture, manipulation and conversion software is available on the WWW at <http://www.quarterdeck.com>.

If you want to locate some shareware or freeware software for screen capture use, I suggest you try the following site on the WWW which allow you to search for shareware which will run under particular designated platforms: <http://www.shareware.com>.

You should conduct a search for "screen capture" software for your particular platform, e.g. DOS, Windows, etc. The search results will provide you with hyperlinks to Internet anonymous FTP sites from which the particular shareware may be downloaded. (This particular WWW site is extremely useful for locating immediately downloadable shareware of almost any identifiable type.)

## DIGITAL CAMERAS AND VIDEO FRAME GRABBERS

Digital cameras and video frame grabber devices may each be used to capture and convert images of "live" or natural scenes into digital image files.

Relatively low cost (i.e. less than \$500) digital image cameras are now available from several sources including Casio, Canon and Kodak. Pictures may be taken in color (or in grayscale) with

these digital cameras in essentially the same manner as with conventional film cameras. The important differences are: (a) each image is stored digitally in a file in an electronic memory in a digital camera rather than chemically on a photosensitive film as in a conventional camera; (b) the pixel resolutions for images taken with the current crop of low cost digital cameras correspond general to VGA screen resolutions or slightly better; (c) in contrast, the effective "pixel" resolution with a conventional camera with photosensitive film is much, much higher; (d) the digital images stored in a digital camera are "developed" by downloading the files to a computer, manipulating or converting the digital image files, and then either displaying the image on a computer screen or printing it on a printer connected to the computer; (e) images (exposures) stored on conventional photosensitive film are "developed" by a chemical process, and then printed using further optical and chemical processes.

Takashi ("Taka") Yoshizaki, JA3BN, near Osaka, Japan has a very interesting set of WWW pages accessible over the Internet at <http://www.hotline.co.jp/~tomando/ja3bn/related.html> which describe several of the current digital cameras. The digital camera manufacturers also have WWW sites with information about their products. Kodak - <http://www.kodak.com>; Canon - <http://www.canon.com>; and Casio - <http://www.casio.com>.

If these sites don't give you enough information for your taste, you might wish then to try a subject search of all indexed WWW sites using the Internet search engine sponsored by Digital Equipment Corporation at <http://www.altavista.digital.com>. I strongly recommend you learn to use the "advanced search" features of this excellent WWW facility so that you can conduct narrow, focused searches to avoid being overwhelmed with lengthy search results of limited interest. The search results at this site are provided as hyperlinks to other WWW or Internet sites having the information of interest.

A major difficulty for amateur photographers taking conventional still-image camera pictures is that considerable practice and experience is required to obtain a "good" picture composition, i.e., "good" arrangement (and the relative arrangement) of desired objects within sight area of the image. Video camera recorders, on the other hand, largely avoid the picture "composition" difficulties of still-image photography for reasons to be described. A VCR records onto the video tape a succession of slowly varying still-image video frames according to the particular video (television) format being used. For example, a VCR using the standard NTSC television format (used in North America and also in other parts of the world) records 30 video frames per second. Because so many successive frames are recorded, still-images with "good" composition can invariably be found by stepping through and examining separately the large number of separate frames recorded by a VCR which has been panned over a particular scene for even a short period of time.

One minute of video recording of a slowly time varying scene with the VCR camera location moving slowly will include 1,800 (=30X60) separate video frames of the subject scene for example. Imagine that the desired picture is of a small group of individuals who are all supposed to look at the camera and smile at the same time. Every amateur photographers will attest to how difficult it is to get a "good" picture of such a scene. But,

very likely, some number of the 1,800 video frames recorded with a VCR over a one minute time interval will have "excellent" composition with everyone standing in the right place looking at the camera with eyes open and smiling!

Video "frame grabber" devices now available as low cost computer accessories take advantage of this circumstance and allow still digital images to be "captured" from video sources. Typically, a video source (e.g. the output from a video camera or a recorded video tape being played) is provided to the input of the "frame grabber" device connected to the user's computer. The user observes the succession of video frames on the computer screen and selects desired frames to be captured as still digital image files. A user can walk around with a portable video camera recorder and fill up a VCR tape with video images of whatever scenes he wishes to record. The user can later replay the VCR tape into the video "frame grabber" to pick out particular still images to be captured and saved as digital image files on his computer.

Video "frame grabber" devices come in many forms: some plug into slots inside the computer and some are external and plug into the parallel port on the computer. I have personally used and am very pleased with the performance of an external video frame grabber which plugs into the computer parallel port known as the SNAPPY device. SNAPPYs are widely available for less than \$200; more information is on the WWW at <http://www.play.com>.

The pixel resolutions for still digital images files captured with a frame grabber from a video source are of VGA or better quality. Thus, a video camera recorder together with a video frame grabber has a slight pixel resolution advantage for generating digital image files compared to the current crop of low cost digital cameras. Digital cameras, on the other hand, are easier to carry and more rugged than video camera recorders, but require the user to have greater skills as a photographer to produce digital image files with well composed pictures. The choice or preference depends upon subjective, individual factors in all instances!

### **SHEET MEDIA IMAGE SCANNERS**

The basic scanning process of a sheet media image scanner essentially "copies" and then converts the desired image into a digital image file. A wide variety of high quality hardware scanners are now available for \$1,000 (and also considerably less) as computer input devices. The image to be scanned may be an image printed, drawn or displayed on sheet of paper, in a photograph, or on like media. Once the image has been scanned into the computer, it is saved in a digital image file in preparation for further analysis or manipulation by other imaging software.

Scanners come in all types: color, grayscale and pure black and white, and with a wide range of user selectable dpi (dots per inch) scanning resolutions. All work in a similar manner once set up. The medium with the image to be scanned is placed on the scanning bed, fed into the scanner or whatever as necessary to activate the scanning process. Software associated with the scanner gives the user control over many parameters relating to the scanning process, and typically gives the user a selection of digital image formats in which to save the initial scanned image.

Generally it is desirable initially to save a scanned image using a file format which preserves as much detail as possible about the digital image (e.g. \*.TIF, \*.BMP, etc.). The file can be later compressed or the level of detail reduced by editing and image manipulation software. In any event the end result of the scanning process is a digital image file which contains a "copy" of the image which was scanned.

Many offices, individuals and service organizations now have scanners. It should be easy to find a scanner nearby and to get someone to scan a photograph, etc. for you at low cost or for no charge to try this out. Remember to take a blank diskette with you!

JA3BN also has several pages of information relating to scanners at his excellent WWW site accessible over the Internet at <http://www.hotline.co.jp/~tomando/ja3bn/related.html>. I suggest you might want to start there for more information. If you don't find enough, next try <http://www.altavista.digital.com>, the WWW search facility mentioned above.

### **DIGITAL IMAGE PROCESSING AND MANIPULATION**

Good software is a key to the creation, use, modification, editing, manipulation, conversion and display of digital image files. Fortunately, many, many good software packages, both commercial and shareware, running on DOS and under Windows are available. The capabilities and the quality of such software is improving constantly.

In an earlier Part, we mentioned the LView Pro shareware which runs under Windows and which has been posted for downloading on IDRA's Internet anonymous FTP site. Since everyone (with Internet access) can easily get this, I will mention some of its specific capabilities.

LView Pro includes basic capabilities for digital image format conversion between any of the (few) supported file formats. The process is quite simple: open a digital image file a particular supported format and then save the same file in a different supported format. Quite simple! Some of the commercial products such as HiJaak Pro and Corel Draw support a much wider range of file formats, and thus allow conversions between many more formats. Having many, many different file formats available is, however, to my mind, somewhat similar to having hundred of different fonts available for printing text — most are not needed and only a few (less than 10) are used or encountered regularly.

LView Pro also includes an impressive array of image enhancement, contrast and brightness adjustment, color adjustment, image feature "edge" detection and enhancement, image sharpening, smoothing and blurring, grayscale and color palette adjustment, color conversion and reduction, image cropping, resizing and rotation, image annotation, etc., etc. capabilities. Many, many commercial packages such as HiJaak Pro, Corel Draw, Fauve Matisse, PaintShop Pro, etc. also contain similar and more extended capabilities.

If you want to look for readily downloadable shareware of a particular type for a particular computer system, be sure to check out <http://www.shareware.com> as mentioned above.

This is a "learn by doing" activity and the best way to learn about this is to get some good software and start experimenting with it. Incidentally, there are many types of digital image files readily available so you do not really need a scanner, a digital camera or a video frame grabber to start learning about this.

### **A DIGITAL IMAGE FILE FROM JAPAN OVER THE INTERNET**

Does this digital image stuff actually work? Yes! Just as I was completing this article, Taka, JA3BN sent me an e-mail over the Internet with an "attached" digital image photograph taken earlier in the day of his XYL, Fumie, and my younger son, Brian - KE4RTL, standing near the entrance to grounds of the famous Himeji Castle in Japan. (See image.) (Brian has been studying Japanese for several years and is spending 8 weeks studying and traveling in Japan this summer.) Taka reported that he took the photograph with his Casio QV-10 digital camera and then

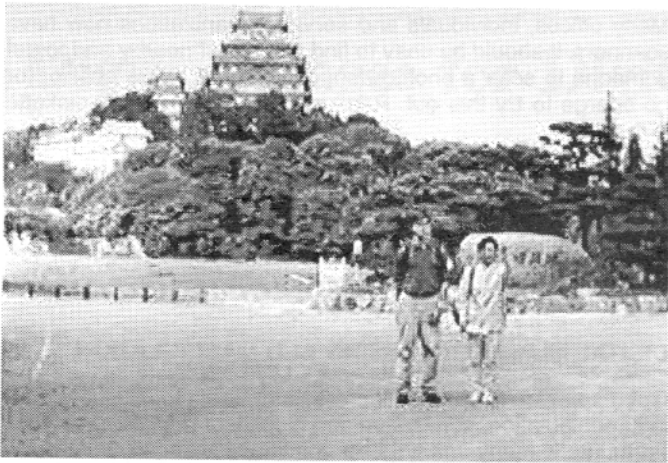

downloaded the image from the camera to his computer in Casio's \*.CAM file image format. Next, he used the Image Pals software to convert the \*.CAM image to several more widely used digital image formats. The particular color \*.JPG file which I received and from which the accompanying B&W image is prepared contains less than 12K bytes.

Because of the reduced file size for this digital image, I cannot be sure as I write how well this image will appear ultimately when printed in the Digital Journal. The printing process itself can sometimes degrade the appearance of the digital image. Displayed on the computer screen right now as I write, the color is reasonable and the Himeji Castle scene and the individuals are identifiable.

But the Internet isn't HF radio, so why should we mention this at all? First, the process for generating the digital image file is exactly the same — whether the digital image file is to be sent via HF radio or as an e-mail attachment (or as file being transferred via ftp) over the Internet. Additionally, it is necessary to understand some basic facts about digital file transfer protocols in order to successfully send a binary file over the Internet or over HF radio. The basic digital processes involved are actually quite similar — except for the actual transmission medium — as we will see shortly.

The Internet's SMTP e-mail handling protocol was adapted a number of years ago to add the MIME protocol extensions to allow binary files to be attached to e-mail for forwarding over the Internet. One of the principal problems addressed by the MIME system was to provide automated file conversions so that binary files could be sent and received over those portions of the Internet network which did not support the transfers of binary 8-bit files. Fortunately, modern Internet e-mail software handles the MIME file conversions automatically and almost transparently for the users. As a result of these advances, we no longer often need to use the old UUENCODE and UUECODE file conversion utilities which previously were used to send binary files in e-mail over the Internet. We will see in a moment that similar approaches (to UUENCODE and UUECODE) are useful for sending binary files over ham radio HF radio links.

#### **TRANSMISSION OF BINARY (DIGITAL IMAGE) FILES OVER HF**

The Clover mode protocols developed by Ray Petit, W7GHM, and HAL Communications include built-in binary 8-bit file transfer capabilities for linked Clover connections over HF radio. HAL's PCC software as well as the XPPCI and the EXPRESS software all offer facilities to make 8-bit binary file transfers with Clover very easy. As a result, arbitrary 8-bit binary files (e.g. digital image files) may be easily transferred over linked Clover connections using any of these Clover softwares.

The current version of the EXPRESS software for Clover by Peter Schulze, TY1PS, includes particular digital image editing and handling facilities, including a facility for the automatic exchange of binary digital image files (of the operators) upon an initial Clover linkup. For this to work both ways, each operator must create and load on his system in a particular directory, a suitable digital image file with his callsign followed by the \*.CMP extension (e.g. W4ZB.CMP). (Note: the contents of that specially named and located file do not have to be a picture of the operator!) Peter wisely selected the very efficiently compressed \*.CMP image file format for this. EXPRESS also recognizes automatically whether the counterpart station's binary digital image file has been previously transferred, in which case, that image file (i.e. CALLSIGN.CMP) is loaded and displayed immediately on the EXPRESS screen upon initial Clover linking.

The situation for binary image (8-bit) file transfer is not so easy with the older and other current HF digital modes except for PACTOR. Fortunately for those of us interested in this, Bob Lewis, AA4PB, has devised a simple solution for transferring 8-bit binary files over linked HF PACTOR connections. This was described in a short article in the July 1996 Digital Journal which mentioned that Bob has released his PTModem protocol and software which accomplishes this feat to the public domain (and is available on the Digital Journal website).

In a manner somewhat like the old UUENCODE and UUECODE file conversion utilities of the Internet, AA4PB's PTModem software converts pure 8-bit binary files into a special intermediate \*.PTM file which contains only symbols from the PACTOR permitted symbol set which can be successfully transferred over a linked PACTOR connection without interfering with or disrupting the PACTOR link itself. The contents of \*.PTM file are then copied to (or placed) in the PACTOR transmit buffer and sent over a linked connection. PTModem does not provide any automatic error correction capabilities, but relies instead upon the linked PACTOR protocol itself to provide error-free transmission of the symbols in a \*.PTM file. The symbols from the \*.PTM file as received at the receiving end are then processed by PTModem to recover the original 8-bit binary file, complete with original file name.

The pertinent PTModem executable files are in a file named PTM31.ZIP which is available from the IDRA's Internet anonymous FTP site. Bob has included with PTModem an excellent tutorial which describes the operation of the PTModem system in considerable detail. AA4PB deserves our praise for devising and contributing this straightforward approach which allows 8-bit binary (digital image) files to be transferred easily over linked PACTOR connections. Everyone interested in sending binary digital image files over PACTOR should try this out!

A simple and straightforward adaptation of AA4PB's PTModem would also easily permit 8-bit binary (digital image) files to be transferred over linked AMTOR connections similar to what is now possible over a linked PACTOR connection. An adaptation is needed, of course, because only a smaller permitted symbol set may be successfully transferred over a linked AMTOR connection; the extra symbols allowed over a PACTOR link would need to be eliminated for use on AMTOR links. I mention this only as a point of interest to test the reader's technical understanding, not because I am suggesting that AMTOR links be preferred to PACTOR links for HF binary file transfers; to the contrary, the PACTOR protocol which was designed well after the AMTOR protocol, has a much larger permitted symbol set and is inherently more efficient for binary files transfers using the PTModem approach.

In Part I, I mentioned that it was technically feasible to write software to permit the transfer of 8-bit binary digital image files using RTTY, but I was not aware that this had ever been done

in for ham radio use. I have received some questions about that so I will elaborate briefly. RTTY software which would do this would need to accomplish two fundamental purposes: (1) convert the original 8-bit binary digital image file into another, intermediate file which contained only a subset of the symbols in the permitted RTTY symbol set (e.g., all of the 26 capital letters of the alphabet only) in a manner so that the original binary file, complete with original file name could be reversibly recovered from the intermediate file; and (2) implement an automatic forward error detection and correction scheme to assure RTTY symbol transmission integrity so that the intermediate file could be reliably reconstructed without error at the receiver.

This first requirement for such a RTTY software system could be met (inefficiently, but usably - as with AMTOR) by extending the PTModem approach discussed above. The second requirement is technically feasible, but much more challenging because an unconnected transmission protocol like RTTY does not provide a rapid or immediate ARQ (automatic repeat request) feedback to the transmitter upon detection at the

receiver of uncorrectable symbol transmission errors. The connected ARQ modes such as Clover, PACTOR and AMTOR, of course, can do this which allows for a much easier and more reliable error correction system design. More detailed discussion of automatic forward error detection and correction schemes is beyond the scope of this series.

### CONCLUDING COMMENTS

Times are changing. Computer equipment and software which is readily available for modern digital mode HF ham stations, coupled with a modest amount of operator know-how, provides an easy capability for generating, manipulating and sending complex digital image files over ARQ HF radio links using both PACTOR and Clover. This is also technically feasible, although with much less efficiency and only after overcoming difficult design challenges, with the older HF digital modes such as AMTOR and RTTY.

73 Paul S. Richter W4ZB

## The International Scene

*A regular look at the odds & ends from around the digital globe*

*Edited by Jim Mortensen, N2HOS*

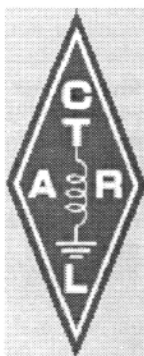
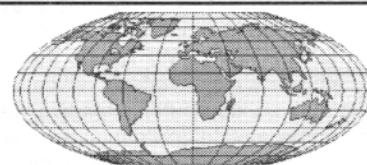

It all started when Bolon BV5AF visited the Digital Journal website. He happened to note an error in one of AA5AU's DX notes. Seems as though a reported callsign should have contained a B instead of a Z. That happens! In any event, I sent a message back to Bolon asking for an update of the amateur radio situation in Taiwan. Bolon, who is a physician, responded quickly and in detail, because there are some important developments taking place this year. Aside from the new license categories described below there is also a DXpedition plan of note. So watch the activity of CTARL, the Chinese Taipei Amateur Radio League. This is the organization for all BV hams.

There are now more than 1500 licensed BV stations. And thanks to Bolon Lin for providing this important information to the Journal readers.

The new Amateur Radio Rule will come into play this August. There will then be four classes of stations.

The 1st degree will have no limitation on power output. They must pass a 20WPM code test. Their callsign forms are 2X2, like BX1AA, BX3WW, BX8OB, etc.

The 2nd degree class will have a maximum output of 1 KW. They must pass a code test at 13WPM. Callsigns are also 2X2, like BV1AA, BP2AB or BM8WC.

The 3rd degree requires 5WPM code and has a maximum output of 200W. Their calls will be 2X3, such as BX2AAA, BX8WWW, etc. Third degree hams may work only 21/28Mhz and V/UHF.

Fourth degree requires no code test, but they are limited to 144/430mHz, maximum output 25 watts. The callsigns in this group are also 2X3 such as BN1AAA, BP3WDV.

Repeater stations are 2X1, like BX4A. Special or club stations are also 2X1, such as BV5Y or BV2Y. BV5Y is CTARL Headquarters stations are Changhua, BV2Y in Taipei, BV7YA is Kaoshiung, BV8YA is Hwalien and BV4YA is at Taichung. There is one special station BV2A, the call for Mr. Tim Chen, the founding President of CTARL. This is the oldest amateur station in Taiwan.

One more important thing should be noted. Taiwan will have new prefixes after July 1996. They are BM, BN, BO, BP, BQ, BU, BV, BW, BX. BO1 is Matsu Island. BO2 is Kimen Island. All BV9's are island stations—BV9A is Pinhu, BV9P is Pratas, BV9S is Spratly and BV9O is Orchid.

"Please note that CTARL will have a BV9S DXpedition in the near future. We now have a team working on this proposal."

QSL should sent direct or to CTARL at CTARL Bureau: P.O.Box 73 Taipei 100 Taiwan.

By the way, it is easy to get a temporary license in Taiwan. If you are going there, or passing through, all you need to do is write, fax, Email or call CTARL and they will provide the necessary paper for up to six months of activity. It can be renewed every six months as well. There is no charge for any of this.

On the personal side, Bolon say, "My xyl, Katy Chen BV5AG, is a member of LIONS, President of her club, Dist. 300C3, and is active in the Hunting LIONS program. My call sign is BV5AV and BV5Y and I am a ROAR-Taiwan. (ROAR = Rotarian of Amateur Radio). I'm a Rotarian of Dist. 3460 and President of CTARL & TAMSAT."

Addresses: E-mail 1) bv5af@ms1.hinet.net, 2) bv5af@show.org.tw, 3) bv5af@amsat.org. CTARL Headquarters (Chinese Taipei Amateur Radio League): Tel:+(886)-4-7388746, Fax:+(886)-4-7385441. P.O.Box 1039,Changhua 500,Taiwan,R.O.C



# Across the Pond

A look at the digital-doings of our European neighbors

by Neal Campbell, AB4MJ/ON9CNC • 10817 Ann Davis Dr. • Fredericksburg, VA 22401

Internet: neal.campbell@ping.be



We are heading into the long, hot days of summer, a great time to start preparing for the biggest RTTY contest of them all, the CQ/IDRA WW RTTY Contest. Its time to start repairing antennas, upgrading modems or filters, testing out the amp if you love high power (who doesn't if they are really honest with themselves!) and making sure that dreaded TVI/RFI will not make your contest effort DOA.

The CQ/IDRA WW contest is the last weekend of September and you will go a long way towards getting RTTY DXCC by seriously participating. If you want to maximize your fun, get a friend who has never operated in a RTTY contest to do it with you. I find that RTTY contesting with friends is the most fun I have ever had in amateur radio. Since you are letting the computer (and RTTY by WF1B) do the work, you can joke, laugh, discuss politics or whatever while you are running a pile-up. Since it is so computer intensive, its a great mode to teach newcomers how to contest.

With luck, I will be working the contest at John Devoldere's house, ON4UN. We operate multi-single, which means more than one operator is allowed, but only one signal on the air at a time, and no band-changing within 10 minutes, unless it is for a new multiplier. John has a fantastic contest station, with an antenna farm to kill for.

So, if you are going to be like 500 other hams and work the contest, invite a friend. If you have never worked in a RTTY contest and are interested, send me a note on the Internet. Maybe I can get some volunteers in your area. There is nothing like an exciting RTTY contest to make you a die-hard digital fanatic!

What kind of equipment do you need to be in a RTTY contest? I entered my first RTTY contest using a KAM and a general terminal program with an Icom 725. I worked about 300 contacts during the weekend and was hooked for life. The first thing I noticed, though, was that the IC-725 had no FSK mode so you used AFSK, which means I was connecting the KAM to the radio through the mike jack. Since I was using the SSB selector, I had to use the 2.2 K audio filter. This was the major limitation with my first set-up. Filtering is the only way for your TNC to decode a digital signal in crowded conditions.

Since I was bitten by the digital bug, I decided to upgrade. I bought a used Kenwood TS-940 and my first HAL product, the PCI-3000 HF modem card. Since the 940 had a FSK generator, I could connect the FSK output from the HAL card to the rig, and use the 500 Hz filter. VOILA! All of a sudden, you are picking out signals signals that other guys couldn't copy on a bet. Encouraged by this success, I lost complete control. Rig upgrades, amps, more amps, antenna upgrades: its a sad sad story that is repeated many times. Luckily, I have a wife who thinks towers and new ham radio equipment looks great.

My message, though, is a KAM (or any major manufacturer's HF-capable TNC), a radio with FSK capability (or the capability to use filters narrower than 2 KHz), and an antenna as effective as a G5RV can get you into a contest in a major way. Another alternative is to buy an outboard DSP filter, like those sold by Timewave, JPS or MFJ, and not to worry about the filters on your rig.

One other thing: buy RTTY by WF1B. It has so many nice features that make RTTY contesting simple and fun. Ray has truly created a very special program. There is another article in this issue by Dick, N1RCT. You can order it from the Software Store of IDRA, and once you use it, you will be amazed how a fresh approach to contest software can make such a difference. If you are into CW contests (I am just starting) the TR program has the same sort of brilliance.

## Attachments and Reflectors

Continuing on my last month's discussion of the Internet, I want to talk about two great mysteries for a lot of people: attaching files to e-mail messages, and mail reflectors.

Neither of these are very complicated, it just takes some time to get used to them. Do you remember the first time you talked to a friend using the local 2m repeater? I honestly could not figure out how it worked for a very long time. I had a friend draw a diagram of it and once I could visualize it, I understood completely! Hopefully, I can help you visualize these concepts.

## Text and Binary

If you have ever used a word processor, you might know the difference between text files and binary files. When I first got a computer with a word processing program, I started opening every file on my hard disk to see what it was. Sometimes, when I would open and look at a file (like C:\AUTOEXEC.BAT), I would see a document with words that almost make sense (before I understood what all those statements meant). If I opened a file ending in .EXE, however, strange things might happen. Either the computer would start making strange beeps, possibly lock up, or a message might appear that stated something like "This file has an unprintable character, do you wish to proceed?"

The reason for this difference, is that text is represented by certain bytes that are called ASCII, which are traditionally represented by hexadecimal values of x'20' through x'7D'. Don't worry about what hexadecimal is, as its not that important. What is important is that a computer can store a byte of data in the hexadecimal range of x'00' through x'FF'. When your word processor reads in a file, and it finds a byte that is not an ASCII representation of a character, it doesn't know what to do, and will print something resembling garbage on your screen.

So, a binary file is any file that contains bytes other than those that represent characters. A text file is a file containing only ASCII characters.

Because many of those bytes that do not represent characters are used by the computers and the Internet to signify something special, you can only send files to someone that are text, no binary files.

Now, some of you are thinking, "That can't be right because my friend sent me a program over the Internet, and you just said that a program contains bytes other than just text!" If you can't send non-text data over the Internet, how did you receive the program?



The answer is that either you or the program you used to send the file attached to an e-mail message converted into text. This is a nice feature of mail programs, as they do this conversion without you knowing it, so it can appear like magic. When you receive an e-mail message that has the attached file, either you or your mail program re-convert it back to a binary file.

### Translating Binary to Text

There are three major conversion formats used to translate a binary file into text so it can be transferred over the Internet and then re-translated back into binary:

- MIME
- UUE
- BinHex.

I will not go into the differences between them, only show you how to work with them.

Knowing what format to use is the tricky part of successfully attaching binary files to e-mail messages. You should know if your friend can receive MIME-formatted mail. If he cannot, then you must select either UUE or BinHex. UUE is primarily the conversion format used by UNIX systems, and BinHex is usually used on Macintosh systems. These rules do not always apply, however, because you can get translator programs that run on all systems to translate all formats.

Lets picture what happens when you use a mail program. You are happily typing a note to your friend, when you decide it would be great to send your picture as an attachment. You happen to know he uses the same mail program you use (like Eudora), which can handle MIME-formatted mail messages. You go to the relevant menu item in your mail program and select "Attach file....". You then specify the file that you want sent to your friend. When you are finishing typing the message, you send it. You will normally see that the mail message begins to be sent, then the attached file is sent, and then the mail message completes.

What has really happened is that your mail program sent the header information and your typed text, then realized that an attached file needs to be send. It then converts the binary file into a format called Base64, and inserted it into the mail message.

Lets picture what happens when your friend downloads his mail. When it gets to the mail message with the attachment, the mail program scans the header of your mail message, and sees that it has an attachment. It starts downloading the e-mail message until it sees the beginning of data for the attachment. The mail program then begins to automatically convert the file from MIME into the real binary data and saves it as a new file. Your e-mail message will show that an attachment was received, and the original text is presented.

Now, occasionally you might want to send mail to someone who cannot receive MIME messages. For instance, currently CompuServe customers cannot receive attached files from Internet users. When CompuServe users receive e-mail from an Internet user with an attached file, the attached file is just text within the mail message. So, how to send file attachments to friends that cannot handle MIME?

The best solution I have found is a translator program for the PC called WinCode. You can download this wonderful program from many locations on the Internet.

WinCode is a program that can translate binary files into any of the three main formats, and re-translate them back into binary. It has some nice automated features, like automatically PKZIPPING any file before it translates it, just to make sure that the least amount of data must be sent.

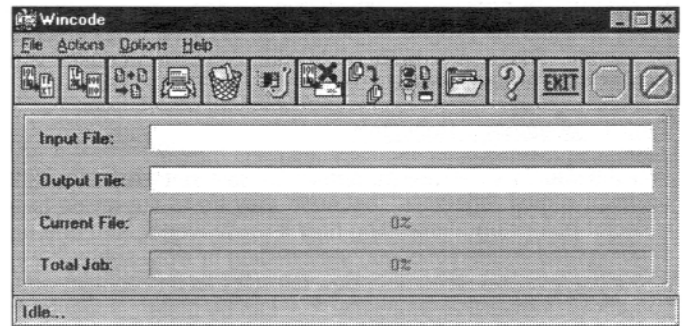

This is the main screen of WinCode. The buttons under the menu item let you encode, decode and do a lot of other things with binary files. To safely send an attachment to a friend, you first need to know if the friend has a utility that can de-code UUE or BinHex files. If he has WinCode on his computer, he can decode any of the three major formats. If the friend can decode UUE-encoded file attachments, you need to translate your binary file into UUE format.

The screen below configures WinCode to translate a binary file to UUE format.

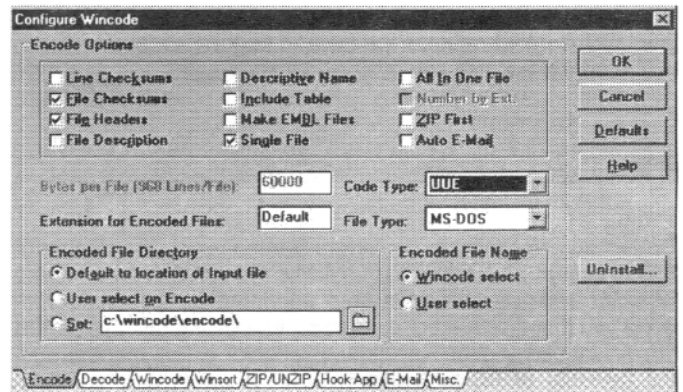

After you have converted the file, merely use the attachment feature of your mailer, or paste the file into the text of your message.

Once your friend gets the message, he will need to know that this has a file attachment. This is usually obvious in the text or header of the message. They will need to save the message as a text file. Based on the translator program they have, they might need to cut the actual text of the message out so the first line contains the first line of the attachment. Often, though, decoding programs are very smart and do not require you to do this anymore.

You can identify what coding method was used pretty easily. If the sender used UUE, you will see a line that looks like:

```
begin 644 0n9cnc.cmp
```

```
M3$5!1""8""""""$8'9''((!X<AL-OKCB>37L+*,D'4^W6=*%&U  
M'PV>8MDLR,<2HYF^1'-9*JK#=YVXG[D;DI'\8<Y*O).<IU.95@>!).
```

BinHex encoded files usually have a name that ends with '.HQX', so if the embedded attachment name has an extension of HQX, you are in luck!

MIME messages usually have a reference to Base 64 in the heading or preceding the text of the attachment.

So, for sending file attachments, the first rule is to know what format your friend can handle. Then, get a great translator/de-translator program like WinCode to handle the dirty work.

By the way, the author of WinCode has a program called WinZip which is my utility of choice for handling zip files. Both

programs are shareware, which means the author requests that if you like the programs that you send him a small amount of money. These are both professional-grade products you should have in your shack!

### E-mail Repeaters = Reflectors

You can usually tell a new person on the Internet when they first discover e-mail reflectors, because they try to subscribe to a reflector before understanding how it really works, and end up sending mail to everyone with the heading or word subscribe in it. Just as you can remember how difficult that first contact was, you should remember that reflectors can be quite confusing!

What is a reflector? A reflector is nothing more than a big, fancy distribution list. If you want everyone on the distribution list to see your memo, you send it to the address of the reflector. A piece of software at that computer site will monitor whenever mail is received that is addressed to the reflector and send a copy of the mail message to everyone who is a subscriber of the list.

The reflectors that I am regularly receiving mail from are:

- Advanced Digital Techniques (all about Clover, Factor II, etc.)
- WF1B or the RTTY Contest reflector
- CQ Contest reflector (dedicated to general contest issues)
- DX
- CT Program
- Yaesu
- Packetcluster (dedicated to sysops of Packetcluster nodes).

Reflectors are similar to the letters column in your favorite magazine, except it happens very quickly. You can send mail to the reflector address asking for help, informing everyone of something you just discovered, or start an interesting discussion. On the Advanced Digital Techniques reflector a few months ago, the benefits of Clover versus Factor II were hotly debated. Many people learned a lot from the discussion.

Just as a magazine has an editor that decides what letters to publish, a reflector usually has a moderator. In most cases, the moderator does not select what e-mail messages are broadcast to the members of the reflector, but he/she will monitor the mail and stop any inappropriate behavior. For instance, on the Contest reflector, the moderator insists that no one advertise products that they have a financial interest. If he catches someone advertising a program, he sends a note to the offending party, often over the reflector, telling them it was inappropriate and asking them to stop. If they do not stop, he can remove them from the reflector membership list.

The first thing to know about reflectors is that you have to subscribe to them, just like you do to automatically receive the Digital Journal. You will not receive any issues of Digital Journal until you become a member of IDRA. Likewise, you will not receive any e-mail messages addressed to the reflector, until you subscribe.

Subscribing or un-subscribing (if you no longer want to be a member) is where most new Internet users get confused. You always subscribe to a reflector by sending a note to a special address. This address is always different from the actual address of the reflector. For instance, to subscribe to the Advanced Digital Techniques reflector, you must send a message asking to subscribe to "majordomo@iea.com". The first line in the text of the message usually says something like "SUBSCRIBE <reflector name>". Sometimes you even have to put your Internet e-mail address after the <reflector name>.

So how do newcomers often make a mistake? They usually send the subscribe message to the actual reflector address. The address of the Advanced Digital Techniques reflector is "adrs-digital@iea.com". Newcomers often send the subscribe message to that address instead of the address of "majordomo@iea.com". It can be embarrassing, but don't feel too bad as it has happened to everyone!

Usually, the address you need to send a subscribe message has the words "listserver" or "majordomo" in the address. If the address to which you are sending a subscribe message does not, stop and make triple sure that you know what you are doing. The reason for having these words in the address, is because these are the names of the programs that manage the subscription lists for reflectors. Your subscription request is usually handled by a program instead of by a person, so you should receive confirmation that you are a member of the reflector very quickly (within 5-10 minutes).

Once you become a subscriber to a reflector, you will start getting e-mail regularly. Its very exciting, because you have discovered a whole new circle of friends. Just as when you are brought into a new circle of friends, it is safe to keep a low profile and what how the group communicates with each other before starting to send a lot of messages.

Too often, newcomers will reply to every mail message they receive. Many times, the reply will be something like "Yea, I agree!". As I wrote last month, if you do not add something to the discussion, fight the urge to just agree. Many people still pay for Internet services on a number of mail messages (or bytes) received, so you are costing people money by just agreeing. By all means, if you have something to add, join in, as that is why reflectors are so interesting.

I know of one friend who always writes a reply to reflector messages and saves them until the next day. If, when he reads them the next day, he feels the message adds to the discussion, he sends it. Otherwise, he trashes the message and saves a lot of people money and time.

Another thing newcomers will do is over-subscribe to reflectors. You can literally receive a thousand messages a day if you do not become selective. A good rule is to review whether you really gained any useful information one month after you subscribed to a reflector. If you did not, un-subscribe, as that will save everyone money and time. I receive about 100 messages a day. I use a good mail program that helps me organize this, which I will explain more next month.

### Make Things Better

In Europe, the Philip corporation has very nice television advertisements stating that Philips is trying to make things better. This is a great slogan, and we should all try to do the same thing.

If you see people making mistakes on the Internet, make it better by kindly offering your assistance. Don't send a nasty note saying "Why don't you stop doing blah-blah-blah!!!" No one is an expert in everything, and everyone appreciates kindness and help. Make it better instead of making yourself look important.

You can also make things better by writing interesting articles in the Digital Journal. I tend to write about things that I think people can use to start exploring, whether it is Clover, contesting, the Internet, etc. In many cases, I am discovering it along with you, so I can relate to what confuses newcomers.

We are trying to broaden our coverage of digital radio, by giving "How-to" articles. If you are interested in sharing your knowledge and experience to Make Things Better, please drop us a note!

*See you next month! 73, Neal*

# DX News

The latest digi-doings from around the globe

by Don Hill, AA5AU PO Box 625, Belle Chasse, LA. 70037 • email: AA5AU@aol.com



## Great RTTY DX in June!

June is not normally a good month for DX in any year, especially in the northern hemisphere, no matter what part of the sunspot cycle we are in. But June 1996 will go down as being exceptional for RTTY DX'ing. On the weekend of the 28th, 29th, and 30th (Friday included), the following rare stations were up on RTTY: CY0AA, FT5WE, FT5WF, JX7DFA, and 9N1ARB.

The CY0AA DXpedition first showed up on RTTY about 1500z on the 28th. They operated for about 5 hours. Earlier in the day, both Sam FT5WE and Jack FT5WF, made appearances on 20 meter RTTY as spotted on the Tokyo DX Cluster (see Digital Doings for more details). The biggest surprise was to see Per, JX7DFA, come up around 2300z on the 28th operating portable from the west side of Jan Mayen Island barefoot with his new Icom radio and a 3 element yagi. He worked North America for over 3 hours.

His method of operating captured my intrigue for the entire duration of this late June activation. At first he operated simplex near 14087 khz. When the pileup got too big, he split it down to "075". When it got heavy there, he then said 070. Then he alternately listened on "070" and "075" while keeping his transmit frequency on "087". After 2 hours, he went back to simplex working stations by the numbers. He listened for the west coast USA and worked several 6 and 7 call area stations. He did everything right! I got the feeling that Per is a better digital operator than he has led us to believe. He handled the pileup like a "pro" whipping out contact after contact. It was a great pleasure to watch. He had promised that he would be QRV on RTTY from the west side of the island in June, and he delivered. Thanks Per!

Earlier in the month, Ray G3NOM came up on RTTY signing /ZC6 from Palestine. There has been a lot of discussion on the subject of Palestine becoming a new DXCC country. There were two different DXpeditions to the region in June. Look for more information next month on this hot spot in the Middle East.

On the 30th, Brad KV5V, operating from the QTH of Dick, 9N1ARB, came up briefly on RTTY for North America and worked two USA stations then went QRT. The band conditions at the time were not very good. After an overall good month of propagation, luck was not with him on this day. Brad had fired up the RTTY gear a few days earlier and worked a couple of stations in Japan and Russia, but did not stay long there either. He left the PK232 with Dick, so hopefully there will be more RTTY from Nepal. Congrats to W3KV and KB3X for making contacts.

Dick has a schedule everyday with W4MWT on or around 14208 khz SSB at 0100z. The best possibility to make a RTTY contact now is to listen for them on SSB and see how the signal is. Then ask Dick to QSY down to RTTY when he is finished with his schedule.

### Bringing a DX Station to RTTY

There are several stations that will QSY to RTTY on request. When asking a station to QSY to RTTY, where do you go? It used to be that 14085 khz was a common DX frequency. In the past couple of months, Europeans have been plagued by a steady mark-like tone on that frequency. Mike, W5ZPA, operating as ZF2PA/ZF8 on a return trip to the Cayman Islands, reports that the Europeans asked him to QSY away from the

QRM. This carrier at times is very strong in the USA as well. When CY0AA showed up on 14085 khz at 1430z on the 30th of June, I could barely copy him because of this QRM. The strength of the interfering signal was S9!

There are other problem areas as well. NA is plagued by 1200 baud packet 14088-14090 khz from Mexico. S79MAD operates on 14093 khz to work JA's because of problems in Japan on other frequencies. Working S79MAD from NA might be a bit difficult with the HF packet going on "093" in the USA. There seem to be problem frequencies all over the world in the 20 meter RTTY band.

Unfortunately, it is a situation we must put up with. The best solution to overcoming these obstacles is to map problem frequencies and try to find one that is good for your best shot to the DX station. For example, by looking at the VK2SG RTTY Notes, one can see that ZS8IR likes to operate on 14083 khz. And that frequency appears to be clean in most of the world (right now anyway). If you come across Chris on SSB or CW, you could ask him to go to "083" and your chances of working him there increase since you are relatively sure that frequency is clear at both locations. But of course, you need to check to be sure "083" is clear of other stations before you transmit.

When moving a DX station to RTTY from one of the other modes and a frequency has been decided upon, there is one more thing to consider. If you read mark tone on your dial (also referred to as *fsk* frequency), and the DX station is using *lsb* (referred to as *afsk* frequency) or vice versa, there is going to be a 2 khz (+/- a few hz) difference in frequency.

When Scott, KB3X, brought 9N1ARB down to RTTY from SSB. Scott suggested "090" and that is where everyone went except 9N1ARB and W3KV, who were found making a QSO on "088". I was there also, and almost called Brad when several seconds had elapsed after John signed with him. But I had no print on Brad and luckily, Scott found the right frequency in time. So if you read *fsk* on your dial, always check 2 khz down. Check 2 khz up if you are using *lsb*. And to be safe, if you don't find your station on either frequency, check the entire band!

### 20 Meter Propagation Improves

Having been through this part of the sunspot cycle twice before, you would think I would know what to expect in the coming rise of sunspots and better propagation. But 11 and 22 years are a long time and all this seems as new to me as anyone. But there are things I do remember. Like 20 meters being open all night long. In June there was a good sign of how 20 meters will be in the future. During the ANARTS contest on the 8th and 9th, the 20 meter band was open nearly 24 hours each day in many areas of the world.

The distinguished RTTY DX'er and contesteer from the left coast USA, Eddie W6/G0AZT, joined me for the ANARTS contest. Both of us were amazed at how long the band stayed open. During a two hour span each night we were working Europe, Japan, and Australia at the same time well after midnight local time.

KG4MN had a great run of JA one Sunday when it was well past 10 p.m. local time in Tokyo. I was on frequency when KH6DRT hooked up with A92GD, both stations were S-9 on my meter at nearly 11 p.m.

It won't be long before these are common occurrences. Soon to follow will be more sunspots. With more sunspots we will get 15, 12, and 10 meters back. 17 meters is already starting to show very good signs of sustained life.

## The WARC Bands

There has been a push toward more usage of the WARC bands for RTTY, especially 30 meters. This is nothing new. RTTY has existed on the WARC bands ever since we had access to them. Yet there has not been any sustained RTTY operation on 12, 17, or 30 meters for various reasons. This should change in the upcoming sunspot cycle. With more digital operators showing up every day, we will need more bandwidth to grow.

The WARC bands seem to be the likely solution at present, but there are limitations to deal with. On 30 meters, the problem is that not all countries can operate there and some regions have strict bandwidth regulations to abide by. Japanese operators are only allowed to operate above 10140 *khz*, whereas German operators are not allowed to operate RTTY anywhere on 30 meters.

The other problem could be that not many RTTY DX'ers have antennas for these bands. As mentioned last month, now is the time to get antennas up and ready for the higher frequencies. I just installed a Cushcraft A3WS WARC band beam for 17 and 12 meters with the 30 meter add-on kit and am happy to report that it works like a charm. It is smaller than the regular A3S tribander (10,15,20) making it easy to install and doesn't take up a lot of room. Whatever you choose to put up, do it soon. You're going to wish you had when P5 shows up on 17 meter RTTY sometime in the year 1999 (yeah, right). Hey, it COULD happen! Ask the guys and gals that still need South Georgia Island because they didn't have a 30 meter antenna.

## Digital Doings

**Annobon Island, 3C0.** A planned trip by Teo, EA6BH, has been canceled. No reason was given. Teo appears fine. He was up on RTTY in July for those looking for the Balearic Islands (EA6).

**Cayman Islands, ZF.** Mike W5ZPA and Wondy K5KR showed up as ZF2PA/ZF8 and ZF2KR/ZF8 for some fun in the sun and RTTY operating from Little Cayman Island in June. QSL to their home calls.

**Cocos-Keeling, VK9C.** Tomo, JH2PDS/1, reports that L.C., VK6LA, activated Cocos-Keeling as VK9CB in late June. Operating time was limited as L.C. explained to Tomo the main reason for the trip was to keep the XYL happy. (Oh boy, been there, done that!) QSL is via VK6LA.

**Crozet Island, FT5W.** After disappearing for nearly 6 weeks, both Sam FT5WE and Jack FT5WF are back on the air after having various antenna problems. Sandy, WA6BXH, reports that Sam has installed a new Cushcraft AP8A vertical and Ameritron AL-80B amplifier. Best times for working Crozet appear to be from 1100-1200z on 20 meters. For NA, look longpath toward JA.

**Faroe Islands, OY.** Carsten, OY1CT, has started getting active again after a short absence, mainly on CW. I asked him about RTTY in late June and he promised to be back on RTTY in the fall. He has been the only active RTTY operator from this North Atlantic island since at least 1990.

**Guatemala, TG.** Mario, TG9AXB, has been showing up regularly near 14083 *khz*. Mario uses a Collins KWM-2 and 30L-1 amplifier into an inverted vee. QSL is direct to: Mario Batres, L38MIS1 Pinares San Cristobal, Zona 8 Mixco, Guatemala City, Guatemala C.A.

**Guantanamo Bay, KG4.** There has been a raft of activity from this location. Rusty, KG4AU is new to RTTY and will be QRV until October '96. Rusty is using 80 watts to a wire antenna that is 390 ft. on one leg, and 150 ft. on the other leg. QSL via N5FTR.

KG4MN has also been active and has been found working a rare path to JA around 1230z on 20 meters. QSL via WB2YQH.

Bill, KQ4GC, followed up his trip in April with another trip as KG4GC in July. QSL via KQ4GC.

**Guinea-Bissau, J5.** Dave, KC9IM (also 4K0IM, TL8IM, YB0AIM, KH2AD & KC6GZ) was to arrive on this African island in July. He hopes to be QRV as J52IM in the CQ WW Phone contest in October. He was to bring his PK-232 with him for RTTY. Length of stay is not known at present. Keep your eyes and ears open for him. QSL via KB9XN.

**Midway Island, KH4.** Frank, AH0W/OH2LVG, is heading up a DXpedition to this Pacific island in early August. The group will include members of the Central Arizona DX Association. RTTY is scheduled and a special emphasis will be made on working EU and AF. QSL via KE7LZ.

**Nepal, 9N.** QSL info for 9N1ARB and 9N1RHM is via Brad, KV5V, for all contacts.

**New Caledonia, FK.** Alain, FK8FI, can be found around 0430z near 14085 *khz*. QSL via F6EFM. FK8FL is also active.

**Norfolk Island, VK9N.** Jim, VK9NS, reported on 20 meter SSB that his PK232 is down. He has ordered the parts to make the repairs. He hopes to be back on RTTY soon. Jim is another operator that will go to RTTY on request from SSB.

**Puerto Rico, KP3, KP4.** Victor, KP3AA, has been causing quite a stir sporting the new KP3 prefix from this Caribbean location.

**Seychelles, S7.** Tomo, JH2PDS/1, gives this report on S79MAD: "Paddy, S79MAD will stay in Seychelles until August, '97. He usually appears at around 12z on 14.093 *mhz*. He works JA by call areas, but does not work split. His home BBS is 9K2EC. He is waiting for PTC 2 to come. QSL via GW4WVO."

**Svalbard, JW.** Ove, LA2IJ, was very active as JW2IJ toward the end of June. QSL to his home call.

**Togo Republic, 5V.** Roy, DL7UBA, activated this African country as 5V7HR in June. Roy took advantage of a rare NA opening around 1100z to work stateside. I found him almost daily CQ'ing, sometimes with no takers on 20 meters. A quick spot on the 'cluster and it didn't take long for the RTTY gang to find him. QSL via the home call at: DL7UBA, Roy Hengst, Fuststr. 6, D-12459 Berlin, Germany.

**Uganda, 5X.** Peter, ON5TT, is active again as 5X1T. Peter was very happy to get back to using a better RTTY setup than he had in Burundi as he explains. "I could not resist to configure the RTTY setup here in 5X, after coming back from 9U. Boy-o-boy-o-boy-o-boy, what a difference! I kinda forgot how comfortable it is to sit back/relaxed and run RTTY pileups using a bit of power, a good DSP filter (MFJ), and a reasonable modem (PK900) again." QSL 5X1T to ON5NT (not ON5TT).

**Western Sahara, S0.** Mike, WB9B, reports that S0RASD showed up on RTTY on the 24th of June and generated a "Big BIG Pileup". The size of the pileup may have scared the operator away, but he promised to try again soon. Let's hope so!

## Web Notes

Gary, W5VSZ, announces the new Web page for the South Sandwich Island DX Group (SSIDXG). The SSIDXG is putting on a DXpedition to 3Y Bouvet in '97 (see last month's DX News). The SSIDXG address is: <<http://ocean.st.usm.edu/~gejones/ssidxghp.html>> The site has all the up-to-date information on the upcoming Bouvet trip. Check it out!

For those of you that are interested in getting a good Telnet program that will work with your browser. Try this site: <<http://www2.telnetnetwork.it/tucows/index.html>> I downloaded CRT which I use in Windows 3.1. I like it better than the telenet.exe program that comes with Windows95 that I use at work. Telnet to the DX Cluster is getting to be a popular way to keep tabs on what is being spotted all over the world. For more information on telnet to the cluster systems, refer to the DX News in June. I hope to include more Telnet information next month. Always be sure to register your shareware software if you decide to keep it.

Remember, DX never sleeps.

73 de Don, AA5AU now at: [aa5au@bayouweb.com](mailto:aa5au@bayouweb.com)

# Contesting

## Coming Events and Awards

by Rich Lawton, N6GG • 14395 Bevers Way • Pioneer, CA 95666



### — RTTY Contests - Coming Events —

Date:	Contest:	From:	Rules in:
AUG 17-18	SARTG WW RTTY	(Sweden)	June DJ
SEP 28-29	CQ/DJ WW Digital	(USA)	June DJ
OCT 19-20	JARTS WW RTTY	(Japan)	July DJ
NOV 9-10	WAE WW RTTY	(German)	August DJ

### — Reminders for Logs —

#### ANARTS WW Digital (June 8-9)

Logs must be received by Sept 2 '96.

Mail to:

Jim Swan, VK2BQS  
Box 93  
Toongabbie, NSW 2146  
AUSTRALIA

#### N. Amer. RTTY QSO Party (July 20-21)

Logs must be postmarked before Aug 20 '96.

Mail to:

Ron Stailey, AB5KD  
504 Dove Haven Dr.  
Round Rock, TX 78664-5926

#### RUSSIAN RTTY WW (July 27-28)

Logs must be received by Sept 13 '96.

Mail to:

RUSSIAN RTTY WW CONTEST MANAGER  
YURI KATUTIN, UA4LCQ  
P.O. BOX 1200  
ULYANOVSK, 4322035 RUSSIA

#### SARTG WW RTTY (August 17-18)

Logs must be received by Oct 10 '96.

Mail to:

Bo Ohlsson SM4CMG  
Skulsta 1258  
S-710 41 Fellingsbro  
SWEDEN

### — — COMING UP — —

#### WAE RTTY CONTEST

November 11-12, 1995

Sponsored by Deutscher ARC (Germany)

**CONTEST PERIOD:** 0000 UTC Saturday to 2400 UTC Sunday. (48 hours)

**REST PERIODS:** Only 36 hours of operation are permitted for Single op stations. The 6 hours of non-operation may be taken in one but not more than 3 periods at any time during the contest, and must be clearly noted in the log.

**BANDS:** 80, 40, 20, 15, and 10M. (five bands) Minimum operating time on a band is 15 minutes. A quick band change is allowed only for QSO with new multiplier.

**MODES:** Baudot (RTTY) only.

**OPERATOR CLASSES:** Note: DX Cluster support is allowed for all classifications.

a) Single op, all bands; b) Multi-op, Single transmitter (only one signal on any band at the same time is permitted); c) Multi-op multi transmitter (no limit to transmitters, but only one signal per band permitted). All HF transmitters must be located within a 500 meter diameter and within the property limits of the station licensee's address. d) SWL.

**MESSAGE EXCHANGE:** RST + QSO serial number, starting with 001. (Multi-multi stations must keep serial number by band.) A station may be worked only once per band.

**QSO POINTS:** Count 1 point for each QSO and 1 point for each QTC (see below).

**MULTIPLIERS:** Each DXCC/WAE country counts as a multiplier. Multipliers count only once per band. WAE country list: C3 CT1 CU DL EA EA6 EI F G GD GI GJ GM GM(Shetland) GU GW HA HB HB0 HV I IS IT JW(Bear) JW(Spitsbergen) JX LA LX LZ OE OH OH0 OJ0 OK ON OY OZ PA SM SP SV SV5(Rhodes) SV9(Crete) SV(Athos) T7 TA1 TF TK UA1,3,4,6 UA2/UZ2F UA1FJL UB UC UN/UA1N/UZ1N UO UP UQ UR Y2 YO YU ZA ZB2 1A0 3A 4J1 4U1(Geneva) 4U1(Vienna) 9H1. MULTIPLIER BONUS: Each mult on 80M counts as 4 mults; each mult on 40M counts as 3 mults; each mult on 20/15/10M counts as 2 mults.

**QTC POINTS:** Count 1 point for each QTC reported to any station NOT ON YOUR OWN CONTINENT. Each station may both send and receive QTCs, but the sum of QTCs exchanged between two stations (sent plus received) must not exceed 10. Each QTC (message) will contain: Time, callsign, and QSO number. Example: "QTC: 1307/WA7EGA/131" means that you worked WA7EGA at 1307 UTC and received his serial number 131. A QSO may be reported only once and not back to the originating station. (You cannot report a QSO with WA7EGA back to WA7EGA for credit.) The same station can be worked several times to complete the quota of 10, but only the original contact has QSO point value. A uniform list of QTCs sent must be kept. QTC 3/7 indicates that this is the 3rd series and that 7 QTCs are now being sent. Record all received QTCs on a separate sheet with a clear indication of the sender. If more than 100 QTCs are claimed, a QTC checklist must show that the maximum quota of 10 QTCs per station has not been exceeded.

**FINAL SCORE:** Multiply total number of QSOs + QTCs by total of multipliers.

**AWARDS:** Certificates will be awarded to highest scorer of the different classifications in each country (a reasonable score provided). Continental leaders will receive a plaque. Each participant with at least half of the score of the continental leader will also receive a certificate.

**LOGS AND SUMMARY:** Use separate logsheets for each band. Indicate clearly all band changes. Duplicate contacts must be clearly marked in the log. If more than 100 stations have been worked on a band, a separate dupe sheet is required.

**NOTE:** Logs violating these rules can be regarded as check-logs.

**DEADLINE:** Log entries must be received by December 15, 1995.

Mail to:

WAEDC CONTEST COMMITTEE  
P.O. BOX 1126  
D-74370 SERSHEIM  
GERMANY

**COMMENTS:** This is the RTTY version of the CW/SSB WAE Contest. While the QTC rules seem complex, one doesn't have to get into the QTC portion of it to enjoy the camaraderie. Besides, there may be a new country to work, or a DXpedition pileup challenge to undertake. A maximum of 36 hours of operation is allowed. Check out those low band bonuses - especially if you've a good shot to Europe.

## — Selecting a Contest to Enter —

Would you like to get into RTTY/Digital Contesting? If so, which contest would appeal to your tastes or skills? Do you think your station could compete with others with similar equipment? Would you like to collect some beautiful awards? The following are a few thoughts that may help resolve your considerations.

Some contests are very popular, while others don't seem to get much activity. Why? Well, many operators get into the contests just for the fun of it. Not for prizes or awards, but just to see if they can work some DX, crack a few pileups, or perhaps to see how many QSOs they can make in one hour while Search and Pouncing. Others are just getting acquainted with the digital modes for the first time and are fascinated by watching various pileups unfold right on the computer screen. Here are some other reasons:

- **Time of Year:** Contests are more enjoyable during the Fall, Winter, and Spring, mainly because Summer conditions on the low bands in the Northern Hemisphere become noisy with static (QRN). This static is so pervasive that even when your area may be quiet, other areas may be having huge lightning crashes that cause most of the QRN and can even make operating hazardous.

- **Publicity:** Most RTTY/Digital contests are sponsored by clubs and organizations outside the USA. Considerable effort is needed to make these contest announcements available to the digital world. The timing of these announcements is also crucial, trying to keep current publications up to date on just what's on the up-coming menu. It's a matter of getting the word out diligently and accurately.

- **Complicated Rules:** Some contests are very simple, while others can be quite complex. Some require charts to tabulate how many points for each QSO, based on how far away each CQ zone is from your QTH. The very popular VOLTA and ANARTS Contests are examples. While this does push operators to work more DX than locals, it does twist things around a bit. We now have computer software to handle this, so it's not as awkward as it used to be. But those who don't have the software will need the Exchange Points Table to compute their score.

- **Band Multipliers:** One of the best ways to relieve crowding on the most active bands is to have band multipliers. If you work a CE or YV on 20M, band mults will encourage you to work a CE or YV on 15 or 40M for an additional mult. Besides, a CE or YV may not seem like much of a rare DX QSO on 20M, but it's a different story on 40 or 80M. The popularity of using each district of W, VE, VK, and JA as a multiplier - and on each band, too - greatly increases the activity on the not-as-favored bands. Of course, band mults are intimately linked to time-of-year propagation problems, where summertime would limit one's activities on the low bands. But that just makes it more challenging.

- **The Exchange:** RST exchange is required of each QSO, otherwise the QSO may not be considered consummated. QSO number is a constant reminder for all to see how many QSOs other stations have. It tends to give you a target to shoot for... an incentive to keep up or even surpass your hidden competitor. CQ zone instantly tells what area of the world the station is located, even though you are not in QSO with that station. This gives you a chance to point your beam toward the DX before you call. There are two reasons for the state/province exchange: a) to keep the awards focused on areas, such as, highest score in a state or province; and b) to help the eager ones into getting their RTTY Worked All States (WAS) certificate from ARRL.

The following list compares the exchange of 15 current RTTY/Digital contests:

Month	Contest	Exchange to Send:	Band Mults?
Jan	ARRL Roundup.....	W/VE: RST + state/province (2 letters) others: RST + QSO nr.	NO
Feb	DJ WW Digital WPX.	RST + QSO nr.	NO
Mar	BARTG RTTY.....	RST + QSO nr. + time in UTC	YES
Apr	EA WW RTTY.....	EA: RST + CQ zone + prov. (2 letters) others: RST + CQ zone	YES
Apr	SP DX RTTY.....	SP: RST + province prefix (2 letters) others: RST + CQ zone	YES
May	ARI International DX	I: RST + province prefix (2 letters) others: RST + QSO nr.	YES
May	VOLTA RTTY DX.....	RST + QSO nr. + CQ zone	YES
Jun	ANARTS WW Digital...	RST + CQ zone + time in UTC	YES
Jul	No. Am. RTTY QSO Party	RST + name + state/prov./country	YES
Jul	Russian RTTY...Russians:	RST + oblast (2 letters) others: RST + CQ zone	YES
Aug	SARTG WW RTTY.....	RST + QSO nr.	YES
Sep	CQ/DJ WW Digital...	W/VE: RST + state/province + CQ zone others: RST + CQ zone	YES
Oct	JARTS WW RTTY.....	RST + ops age	YES
Nov	WAE WW RTTY.....	RST + QSO nr.	YES
Dec	TARA RTTY Sprint...	W/VE: RST + state/province (2 letters) others: RST + QSO nr.	NO

As one can see, creating software to cover ALL contests is a real challenge! And that's just the exchange! Considering QSO points, band mults, zone mults, continent mults, the exchange is just the ice of the tipberg!

((73)) See you in the pileups, Rich, N6GG

P.S.

*Drop me a line with an idea to share,  
Or, drop me a line with an item to air.  
Drop me a line with anger to bare...  
But don't drop ME... 'cause I care!*



Gerry, NO2T and his xyl, Doris, NW2B proudly displaying plaque received for his contesting efforts.

- Photo by NA2M

# Mighty Macros for RTTY by WF1B

*Streamlining operations of this popular contesting program*

by Dick Stevens, N1RCT

P.O. Box 1075 • Wilton, ME 04294 • E-mail: <n1rct@megalink.net>

This popular program for RTTY contesting has many great features for contesting and one is a large macro capability of smart pre-programmed responses that can be sent by keyboard or mouse click. Ray WF1B points out in the instruction manual that you should set them to your taste as they only contain sample data. An interesting thread on the WF1B Internet reflector in recent months dealt with optimizing macros to overcome some RTTY peculiarities and improve your chances for putting good print on the other person's screen. All these ideas came from others ... particularly Glenn AE0Q, Bob K0RC, Brian K6STI, Eddie W6/G0AZT, Bill W7LZP, and Jay WS7I, that I remember. These techniques will also help with other programs; I use them in Lan-Link for DX chasing.

So, let's take a quick look at unique things in RTTY that affect our operating.

## Signal Synchronization

Whoa, RTTY is an asynchronous mode, right? Not really — the TNC must somehow locate the longer Stop Bits in a noisy audio stream, establish the timing it is seeing, and then start decoding characters. By then a few characters may have been missed. By sending a few spaces first, the other TNC has a good chance of establishing sync before you send the real info; so each macro starts with two spaces. And, of course, always have DIDDLE ON if you have it, for the same reason. (See below; all but macro 5 are indented by two spaces)

## Garbage Characters

Unless he is running an AEA TNC with RFRAME ON, the receiver has lots of garbage characters spewing across his screen, not to mention other callers, adjacent stations, etc. You want to isolate your message from this clutter so that it pops out ... and a easy technique is to send a carriage return <CR> before and after your message, quite possibly putting your message on it's own private line of his screen. Even double <CR> might help. (See below; the carriage return/line feed is <CR>).

## "USOS" Problems

When RTTY switches from letters to numbers, it sends a FIG shift character to change to the number/symbols alphabet (these can be actually seen with a program like RITTY by K6STI). When it needs to go back to letters, it sends a LTR shift character. Now the letters alphabet contains the symbol for a plain space ... so when you send a number string like 599 212 212, there are actually three characters sent where each space is; LTR, space, and FIG. If any one is not read properly, a mess results, not to mention the time involved for the extra characters.

The solution for number chains is to use a character in place of the space that is part of the numbers alphabet and does not require any shift letters to be sent. For numbers, the normal one is to use is the dash (599-212-212); this has a higher probability of being printed, it will print noticeably faster, and has less time for qrm/qsb to occur.

For letter chains, the plain space is best. CQ-CQ-DE-N1RCT-N1RCT is NOT good. It is equivalent to leaving spaces between numbers in the FIG/LTR shifts sent. Minimizing LTR/FIG shifts is useful for all RTTY transmissions, and perusing the characters (ARRL Handbook) will pay off. Unfortunately, your callsign will contain a mix of numbers and letters.

BTW, sometimes, well lots of times, USOS will convert a number string to letters; like ?21 EWQ EWQ; in lieu of using the WF1B autoconversion, just look at the letter on your keyboard and then look at the number to the northwest. There it is. Look at an old green keys machine and see why.

## Long/Short CQing

True pileups are rare for the great majority of us in RTTY contesting. We are really trying to catch and keep the attention of someone tuning by every two or three minutes if the band is HOT. If we want a 75 percent chance of a tuner-by hearing us and we want to leave 5 seconds between CQ calls, now quick, how long must be the CQ call be?? LOOOOONG. If your ESP says there is someone already there, a short CQ is in order. So I include both, but 95% of the time I am using the long call. The limit is 100 characters. (Macro 1 and 10, Fig. 1)

So you managed to attract someone who does not know what you need. I have a macro programmed which gives the info I want from them (shift-F1), but usually I prefer to type "alt-K FB, JUST NEED YOUR CQ ZONE WHICH IS 05 AND TIME WHICH IS 1245 alt-K" based on what the WF1B screen is showing. Their response is instant. Come to think of it, that could even be a macro. Then thank them profusely. Return business is everything.

## WRK B4 CUL (alt-B)

Before smart contesting software, it was normal to avoid dupes like the plague, but it is not the best move in RTTY contesting. All contests allow identified dupes to be included, in fact require it. So when an apparent dupe calls you, just go ahead and work him again. I want to be sure I am in his log. I then reserve the alt-B key for when I get the finger.. ah .. WRK B4 CUL key. First check that you have the callsign right and that you are on the right band; he just may be right. Then send a alt-B message, when he is free, asking for a dupe. I always get instant exchange, no questions asked with this approach. Anyone calling CQ should know that if the QSO is not in my log, he will not get credit, and vice-versa. See below, B4 macro.

## <HI> File

This is not a problem, it's an opportunity unique to RTTY contesting. With very few exceptions (Hi Ron), RTTY contesting is slow paced for now and Ray has included the ability to address the other guy by his nickname (or whatever) when, where, and if you want it. There is file of 3000 names already made up on the WF1B Home Page, courtesy of PA3ERC, but you may prefer to start a little smaller, using names from your rag chewing log or add them to the PA3ERC file. I make a list of callsigns I worked in the previous contest and make an effort to get a name for the new ones. Of course, I add the new names from my rag chewing between contests. So here are some examples from my file:

```
[HI]
N1RCT=DICK ; plain vanilla

AA4M=BILL
AA4M/6=BILL ; Bill gets around; match must be exact

AA9RR=OM ; don't know, reminds me to keep looking for a regular;
I can find by searching for =OM in my text editor

K4KJQ=GUYS ; Club Call
```

WB6WSL=FOOTHILL ; Foothill College Radio Club  
SM3KOR=LARS, PLS QRO ; Lars runs 15 watts into a coat hanger, you know  
W6/GOAZT= EDDIE MY MAN ; don't mis-interpret this one, pls  
WF1B=EXALTED MASTER ; short form for contesting

Don't include the comments . . . they WILL print. And it is probably better to omit names than to get it wrong. I use my Boxer text editor SORT instruction to get them in order and check for dupes, etc. Be cautious when exceeding 3000 names. More memory for names can be created by starting the program with "RTTY -2K ANARTS96"; this reserves memory for 2000 instead of the default 3000 qso. When WF1B 2.5d fires up, it shows the available memory; 15K left seems fine.

### <HI> in Macros

Here is your chance to be different: put the <HI> up early, or at the end; try for a natural use that isn't glaringly obvious. I think I get a lot of calls, number 001, from guys that just said "Hey Mabel, watch what happens when I call this lid tester . . . but he's a good old boy, always remembers my name." So the use of <HI> in the macros is not always wasted bandwidth, and even if it were, it's a nice touch. See below, macros 3,8,9, and B4 for my usage (at the moment).

### Detailed Macro content

Here's the macros I used for the ANARTS contest back in June. The required exchange was RST-CQ Zone-Time. Only six of the 41 keywords available were used; and <11> and <15> could have been typed directly. So effective macros do not need lots of keywords (which are best left for printing QSL labels), Your own are quick and easy to create and check out . . . just shut off the radio and press all the keys. The relation between the macro and what comes on the screen will let you fine-tune what you want it to do.

#### Keywords used:

- <1> The callsign appearing in the lower left box (by mouse click, arrow key, or direct typing)
- <11> Your callsign as entered on the startup page (or just type your call)
- <13> Your computer clock time (set to UTC)
- <15> Your CQ Zone, from the start up page (or just type it in)
- <CR> Causes the other screen to reset to new line
- <HI> Substitutes name in Friend.ini

F1 = <CR>CQ CQ TEST DE <11> <11> <11><CR>  
(short cq; some like to put DE in front of each callsign usage to help WF1B spot calls; I find it clunky and slow)

F2 = <CR><1> 599-<15>-<15>-<13>-<13> <1> DE <11>  
KN<CR>  
(first response to caller; be sure that you have the right exchange; use alt-H to see them all. The ending callsign exchange is another chance to get the callsign right and gives the guy a few seconds to get his response composed)

....Here you will receive the callers exchange info ....

F3 = <CR><1> QSL <HI> TU 73<CR>QRZ? DE <11> <11>  
K<CR>  
(last response to caller; usually done by page-down key to autolog; I leave the <HI> until last so that the caller does not get distracted and try to remember my name on my time)

F4 = <CR><1> ?? AGN PLS DE <11> K<CR>  
(use for partial callsign, no callsign, bad exchange, etc)

F5 = <1> DE <11>  
(use after alt-K for manual typing of a message)

F6 = <CR>DE <11> <11> <11> <11><CR>  
(when all you got was a QRZ?)

F7 = <CR><1> DE <11> <11> <11><CR>  
(first response to someone calling CQ)

....Here you will receive the CQer's exchange info use F4 if poor copy ....

F8 = <CR><1> QSL <HI> 599-<15>-<15>-<13>-<13>  
<11><CR>  
(last response after you have his info right)

F9 = <CR>GL <HI> 73 SK<CR>  
(when a CQer sends special thanks, etc)

F10 = <CR>CQ CQ ANARTS TEST DE <11> <11><CR>CQ  
CQ TEST DE <11> <11> <11><CR>  
(LOOOONG CQ)

B4 = <CR><1> <HI> I NEED A DUPE PLS DE <11>  
<11><CR>  
(When you are told WRKED B4, but it is not in your log)

F5 breaks all the rules . . . it's for use after pushing alt-K for to converse over something. The keys to the left are generally for use when you are calling CQ and the ones to the right, when you are tuning around. F9 is for when you must acknowledge some comments.

### Shift-PF Macros

If 11 macros just will not contain your ideas, you can add more via the {HIGHKEYS} section of the RTTY.ini file. You can't change them without exiting RTTY and may not use them much, but I have included mine anyway. In general, they are long-forms of the normal keys for the hard of hearing. The keywords are the same, but it probably best to keep the length to one visible line in the editor screen.

#### [Highkeys]

F1= <CR><1> PLS NEED UR CQ ZONE AND TIME UTC  
<11><CR>

F2= <CR>RYRY 599-<15>-<15>-<15>-<13>-<13>-<13>  
?<CR>

F3= <CR><1> DE <11> <11> <11> <CR>

F4= <CR><1> BAD QRM AGN PLS DE <11> KN<CR>

F5= <CR> PLS FREQ IS IN USE 73 SK<CR>

F6= <1> DE <11>

F7= <CR><1> DE <1> <1> <1> <1><CR>

F8= <CR>599 599-<15>-<15>-<15>-<13>-<13>-<13> QSL?  
DE <11><CR>

F9= <CR><1> FB <HI> GL 73 DE DICK <11>SK<CR>

F10= <CR> QRL? DE <11><CR>

HIGHKEYS ARE THE shift-PFx FUNCTIONS

The most important one here is F10, listen, a short CQ, and more listening. Frequency stealing is not good form and will cost you in the end. Be polite to pirates with shift-F5 but I follow with a LOOOONG CQ immediately. I put a piece of masking tape above the PF keys and label with the normal and shift macros.

### Summing Up

Good macros can make a marked difference in your contesting, both in getting more contacts into the log and making it more fun. They are also the image you will project. Don't be afraid to change them on the fly when something does not seem to be effective. And always be prepared to hit alt-K and talk directly. You must create a lot of diddles to attract attention and keep encroachers at bay .. and the macros are where we start.

73, Dick N1RCT



# Lowbands and RTTY from Burundi

## A DXpedition to 9U

by Peter Casier, ON6TT / 5X1T

E-mail: <petercasier@wfp.or.ug

The idea to activate 9U on the lowbands originated in 1995 when I was leaving for 9Q. Long time friend John-ON4UN asked to go to 9U as this was one of the countries which was not added to his list of 260 odd he had worked on topband. John has always been a great help in preparing my trips and assisting with his valuable knowledge during our past DX operations, so.... Unfortunately, in 9Q, I was pretty much glued onto my spot in Goma, so no 9U. When beginning of this year, I took up a telecom assignment in the United Nations World Food Programme (the main food aid organization of the UN), Burundi was one of the countries I was responsible for. Each time I spoke to John, it was: 'And when 9U?'

And 9U came unexpectedly. All was prepared in just a few days time, as due to the worsening security situation, I had to plan the professional part of my trip very fast. I contacted 9U5CW (EA1FH) whom I knew from the Goma days. Alfredo works in Bujumbura for the United Nations High Commissioner for Refugees. He said that I could stay with him, and that he had a large garden to put up the lowband antenna I had with me. There is a long story to this antenna, as it traveled with me to 9Q5TT, D2TT/D3T and then to VK6 ready to be shipped to Heard Island. I carry this 15m tall inverted L around in a ski bag. It has 6 telescopic tubes of 1.5m, and a top of a fiberglass fishing rod. The toploading wire ends on a plastic egg insulating the 80 from the 160 part. The base has a multitap UNUN, and a series of capacitors, so I can shorten the antenna from below (switching between 80 cw and 75 ssb) and can match it perfectly. This antenna was originally made by John, for the 9Q trip. As a side note, the experiments with that antenna lead to a new design for toploaded monoband vertical we are going to use on Heard.

Two days before the trip, I was proud to tell John about the plans, and made some 160m skeds with him, in case conditions would be so bad I would not be able to hear his prominent signal. The day before my trip, I finally received my Ugandan call, 5X1T, so I could not resist running the piles from my base station in Kampala until 2 am. We left for Entebbe airport 4 hours later. While descending to the airstrip of Bujumbura, the capital, you get a good view on the city, which is built right at Lake Tanganyika, leaning against the hills around it. Right next to Bujumbura lays Uvira, Zaire, one of the sites with some large refugee camps.

We landed in Buja, as the locals call their capital, on Friday May 31 in the afternoon. Picked up by the people of the local WFP office, I was run through customs (no questions asked with a UN diplomatic passport). This was the first time I actually entered Burundi. Being a frequent traveler in the region, I often passed here in transit, but never left the airport. The first glance at the capital of this country which is known for its years long of ethnic trouble, was interesting. It did not seem that this country was in the middle of a civil war and ethnic clashes. The streets were tidy, the buildings were well built and maintained, the cars in good shape. How wrong first impressions can be! There is strict curfew at 9 PM, and every night the Hutu rebels descent from the hills around the city, guaranteeing frequent furious confrontations with the regular Burundi army who are mostly Tutsis.

We had meetings in the office until 5 PM when Alfredo, 9U5CW picked me up and drove me to his home. It was good to see him again after one year and a half. Certainly one of the main char-

acteristics of friendship made in troubled areas like these, and working in the same field, is that they are more intense than day to day friends or acquaintances. We both know that we work in high risk places, and that one day something might go wrong. When we see a friend back, it feels like 'hey we're both still alive and kicking!' Alfredo is a great guy, always well humoured and busy, whom you may ask any favour. He had told me before my arrival that he was looking forward to do 80 and 160, two bands which had not been activated since a very long time. I actually doubt if 9U has ever been on topband before. As both him and 9U5DX, Jean-Pierre, another colleague from UNHCR, are very busy with their job, they had no time to put up anything decent for the lowbands.

Alfredo's house looked great in the glare of the lights in the garden. It was a Spanish like villa, with a wide open porch and patio, great layout of exotic plants and palm trees. The compound lays on the side of one of the hills, looking over the lake - and towards EU, and USA. In the back there is a 40m by 10m grass field, where Alfredo had planned to put up the vertical. His shack was very simple: a Yaesu FT900AT, one car battery, a charger, a Heilset and a CW paddle. No filters, no amplifier. The antenna is a Cushcraft R7, mounted on the roof. Alfredo had a Kam+ RTTY modem, but it was not connected to the rig, because of no connectors.

As it was already 6 PM, we decided to go out for some dinner first, before the curfew of 9 PM. During the meal, we agreed to hook up the RTTY gear first, and to do the lowband antenna tomorrow, as there was not enough light in the back garden. Also, we did not want to take the risk of too many mosquito bites, as malaria is very common in this area so close to the lake. I had taken a toolbox and spare connectors, wires and plugs with me, so we improvised a connection between the modem and the radio. After some fiddling around (which made us laugh by the idea that we were supposed to be telecoms professionals, hi), we got the stuff to work. Some more fiddling to get everything in tune with WF1B's RTTY program (tnx Ray!), and we were in business. First CQ and DF3HD came back. And then... nothing. CQ after CQ, but zip.

New frequency. CQ again. Rig heated up, decided to run 50 W max, in the cramped 10 KHz of the 20m RTTY space. One station per 10 minutes came back. We were a bit disillusioned. 4th station and 1st Stateside was N1RCT. 30 minutes and 6 stations further, we decided to call it quits.

Then it was time to show Alfredo the present I had for him: A CW interface cable for CT. I swear to God, he almost kissed me! He had mentioned in one of the exchanges we had via Email, that running CW with a paddle and no keyer was a pain. I knew he used CT, so the use of an interface cable was evident. I showed him the little label on the connector: "for 9U5CW from ON4UN. Price: one 160m QSO!" "Tomorrow for sure", Alfredo smiled. We run some SSB pile-ups, and asked an ON to phone John to say we would have the antenna up tomorrow. While Alfredo ran the piles in CW (with his new cable), I assembled the low band antenna in the living room.

The next morning, a Saturday, we raised the antenna, and laid out about 20 ground radials on the grass. The SWR on 80, 75 and 160 was perfect, but when we listened on the bands, there was very high electrical interference, probably caused by one

of the generators in the neighborhood (we had no electricity for days in a row). We were worried. Fortunately, this was the first and last time we heard the interference! During the day, we run the piles in CW and SSB. Around 13:00 GMT, I tried 20m RTTY again, and by jolly the hordes had heard me. A whole range of diddles came back to my first CQ. Now this was a challenge, I have to tell you: managing the piles with 50W, a vertical and a Kam+ with NO filters. The Kam could not decode any signal once there was more than one guy calling, and it was clear that my signal was covered by callers. I went for split, spreading the piles. One to two stations per minute was as fast as I could go. A great opening to JA, fed the run for a long time. This felt great. Yes, 9U was wanted on diddle-mode! Once the piles died out, we went for some more CW and SSB, until 19:00.

Time for lowbands to JA (JA sunrise). Numerous CQs on top-band, but no reply. Could not hear any signals neither. Nobody waiting for us on 80 neither. At 19:22, SP5EWY was logged as the first 80m contact. A few others followed, but nothing much. As it was too early for a decent EU run, Alfredo decided to go for a sleep, and I continued on the other bands.

Around 22:00 GMT, I tried for another strategy: instead of calling endlessly on 80m CW, I would look for a good signal on 75m phone, raise a pileup and then announce we would go for CW. After that, we would announce to go to 160. I call it the 'pick and drag' technique, which I use often to drag guys from 15 to 12 and 10m, when I know there is an opening, but nobody is listening there. So said, so done. I8UDB was on 75m phone. I called in, and as usual, Dom gave me the frequency. Signals were good, and I ran a pile in phone. I announced we would go to 3505, woke up Alfredo and let him run 80 CW.

The callers were numerous, our reception was great, but it was clear that our low power and the high static in the northern hemisphere bothered the reception of the others. So the QSOs did not go very fast, and demand slowed on CW with loads of explicit repeats. We announced to QSY to 1823. We thought of running split from the first moment so went RX on 1835. No-one came back. This was sked time with John, ON4UN, but no signal. We looked at each other and were worried. And then, from the darkness of QRM, came a biiiig signal. D-E O-H-1-X-X O-H-1-X-X. Hannu! No surprise he was the first one! We worked him, and listened for some more. No-one. Decided to just call for 'up'-up'. And sure enough, there they were. About 10 QSOs and that was it. Back to 80. More piles. Around 02:00gmt, the first North-American came in: K1ST, shortly followed by Jack, VE1ZZ. More EU, and then more NA. We tried to drag the Americans to 160 but no go. Could only work some EU.

Each 80/160 m band switch, I had to run out, climb onto the roof to shorten or open the strap on the toploading wire. The guards must have thought this was very funny! Back to 80, more NA. And then it died out. Tried 40, but no go. It was 0300 and 80 had died. We went to bed.

Next day, Sunday, same routine: ran piles on CW, SSB, RTTY the whole time, but propagation was real lousy. It also became clear that North America would be problematic in RTTY: no openings were good enough to guarantee a good NA run. Sked on 0000 for ON4UN was nil. Run some more EU on 80. Sked at 01:00 with ON4UN, was nil, more EU on 80 while stateside started dripping in. Went back to 160 half an hour before the sked at 0200, and worked VE1ZZ, and some others. And then, with a blasting signal—daadaadaah daahdit dididididaah dididaah daadit. ON4UN at last. John explained later that on the Saturday night, he run the field day station from ON6MS/P, and slept through our first two skeds on Sunday night. He got us on first call, though—599 both ways. By that time, both Alfredo and myself were tired and went to bed at 4 am local time, to get up 3 hours later to go to work. Both of us had dark circles around our eyes....

Coming back home, it was straight to the radio, mainly RTTY, then later in the night 80-160. Got up at 0000GMT for EU on low bands, and 0300 GMT for NA. Still no JA in the early night. Actually, we heard nothing on the low bands until around 21 GMT, way too late for JA. And this is how it went for the next days: to work early, home around 6 PM, and straight to the radio. We made it a point to get on the bands at 0300 GMT, 0500 AM local time, for NA, and the harvest was good for us.

On Wednesday, I left for a field trip to Ngozi, upcountry in Burundi. Quite interesting. I should say. I slept in a house, where our expatriate staff got a grenade thrown at them one evening a few months ago. The wall was still burned black, and pieces of shrapnel had blown all furniture to pieces. Luckily, no-one was hurt. The next morning, we heard the sad news that 50 km up the road, three Red Cross expatriates were killed in a cold blooded ambush. It was a sad day for all of we relief workers in Burundi, and the whole area. Then Thursday, I flew to Gitega, another site upcountry. A wonderful area, but very 'hot'. Our food convoys in that area are run under heavy military escort. We slept in the office, a nice villa, 20 minutes from town. Next door, there was a convent for retired nuns. I had visited them, asking for some rope and a small mast to get our HF antenna in the office a bit higher. Nice people.

I flew back to Bujumbura and the piles and the next day, I learned that the night after I left, the convent next to our Gitega office had been attacked during the whole night, and that WFP evacuated the office. I had missed the attack by one night! The next weekend, my last one in Burundi, Alfredo and I just kept on plowing through the piles in whatever mode we could think of. We also worked our first JA on 80: JA8DNV, shortly followed by JA4DND, JA8EOT and others. We also has some real good openings to EU on 80 and 160. No JA on 160 though. The NA harvest was good.

One night, our generator run out of diesel, so we operated by candle light, as long as the battery of the portable computer would allow it. It sure must have looked funny to anyone who would see us: two guys and a candlestick, intensely looking at a computer screen and fiddling with a little black box, and from time to time shouting and laughing when once a again, a friend was worked on the low bands...

The Monday came, and we decided that I would leave the low-band vertical in Burundi, until end of August as the demand for 80/160 was higher for 9U than for 5X, mostly cleaned out by 5X4F. Alfredo also said that during his holiday in July, he would shop for an amplifier, and buy the WF1B software and the right RTTY connectors. I hope that by now, some more people have worked him.

I bid farewell to Alfredo, flying back to my base in Kampala, Uganda. It was a great week, and I sure hope we made some guys happy. In 9 days, together, we made just over 3000 QSOs, of which 350 in RTTY, 42 on 160, and 233 on 80.

And ON4UN? He is one more 160 country richer. What is it, John? Number 268 or so? I lost count, hi.

CU from 5X or some other countries in the region before the end of the year. And.... cu from Heard island in Jan'97! Do not forget we still need your support via KK6EK!

73-Peter, ON6TT - 5X1T.

Side note:

*Every year, reliefworkers die in the line of duty, in Africa, in Central America, in Asia or in the Middle East, or in ex-Yugoslavia. Killed in ambushes, or by mines or victims of cold blooded attacks. I'd like to dedicate this article to those friends who left us, and especially those three ICRC delegates, killed in an ambush. Our thoughts are with you. May one day, our work be obsolete.*

# The Contest Chair

Hints, Tips & Inspiration for Better Scores

by Ron Stailey, AB5KD • 504 Dove Haven Dr • Round Rock, TX 78664  
E-mail: <ab5kd@easy.com>

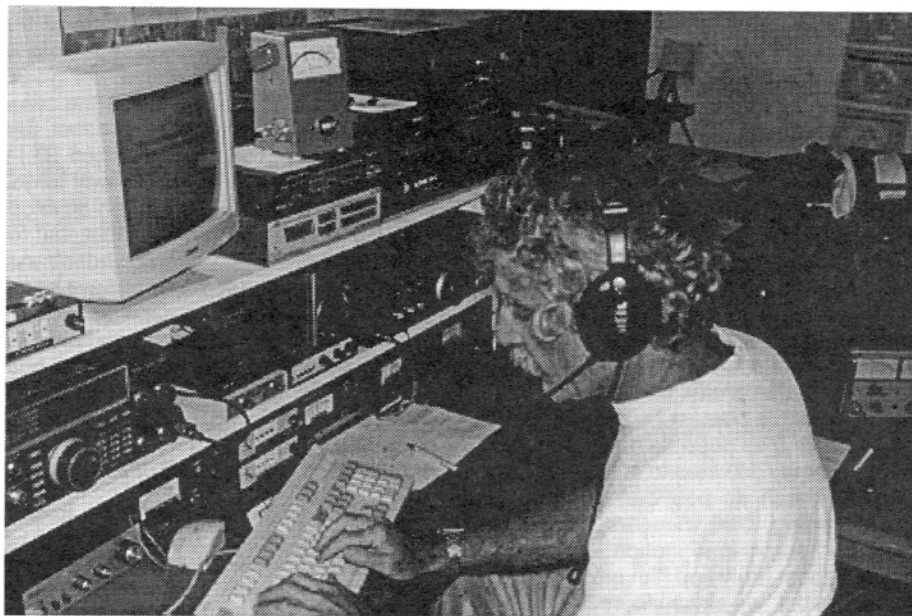

Steve, VE3XO at the controls of his farm QTH in Toronto, Canada

Hello Contesters DXers, Finally all the WPX'96 and CQ/DJWW'95 results are out of the way. Talking about the WPX contest, Jay WS7I has been the main back bone of the WPX contest since we started it two years ago in RTTY mode. Jay is tied up in business and doesn't feel he has the needed time to devote to the WPX contest any longer. Jay has done an outstanding job for the past two years. I would like to thank Jay for all his help and efforts he has given to the WPX contest. Thanks Jay for a job well done.

Starting next year Eddie W6/G0AZT and I will taking over the WPX contest. I truly hope we can do as good of a job as Jay did. Next year's WPX contest logs will come to me. More about that in a future article.

This month we have SARTG Contest and September brings CQ/DJWW contest. I will have a few records at the end of the column for you to shoot at during these classic contests.

The new Vanity call are starting to come out in large quantities now. If you change your call be sure to send it to me. We will list these calls every month in the Digital Journal. List old call plus new call. Example: Old call: WB5NXH, New Call: AB5KD..

This month we will visit with Dr. Steve Tobe, VE3XO. Steve and his wife, live in Toronto Canada. He is a Professor of Zoology at the University of Toronto. He has had a variety of administrative positions and at present he is the Vice-Dean of the faculty of Arts and Science.

Steve has been a ham since he was seven years old when he built his first crystal radio. He says his XYL tolerates ham radio but certainly wouldn't have any interest of joining the ranks.. One obsessive ham per family is plenty!

Steve's station is at his farm, about 8 km from Niagara-on-the-Lake. About 15 km from Niagara Falls, and about an 80 minute drive from his home in Toronto.

## Tower and Antennas:

His station is on 13 acres of property. At the present time he has five towers in the air, all Trylon (made in Canada) self-supporting towers of 80 to 88 feet. Each tower has antennas for one band only 20, 17, 15 and two for 10, with separate buried feedline (mostly 1/2' hard-line) for each. He also has two towers still on the ground, one 120 foot self-supporting Trylon and a 110 foot. needle. He hopes to have time to put these two up this summer. He intends to put big 20m and 40m yagis in these towers. His 20m tower has a single 4 element yagi (designed by Howard VE3WT—now sk). The 15m tower has a K8CC type 5 element yagi on a 42 ft. boom and a 4 element beam, fixed on Europe at 50 ft. These can be phased. On one 10m tower, he has two K8CC type 5 element yagis (30 ft boom), stacked, with the lower beam at 45 ft. and the upper beam at 80 ft. On the 2nd 10m tower, there is a 6 element VE3WT yagi. On his final tower there is a 4 element wide spaced 17m yagi. Steve built all his own antennas, and designed and optimized them using K6STI YO and ELMEC software. All antennas are turned with Hy-Gain Tailtwister rotors.

On 40m, he has a four square of 1/4 wave verticals, elevated about 2 meters. On 80m, he also uses a four square of 1/4

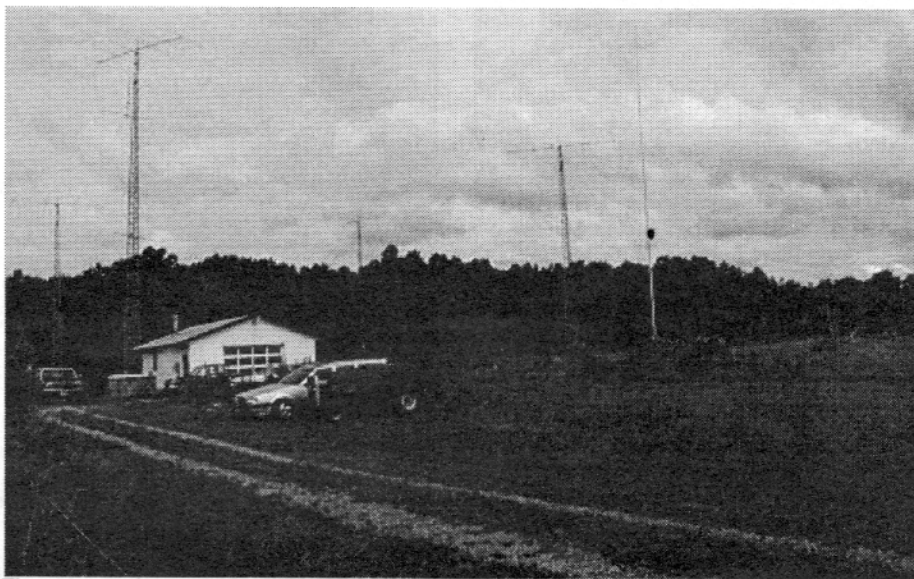

The antenna farm, on the farm, at VE3XO

wave verticals, (not elevated), but he wishes it was elevated. Hi! He has two 900 foot beverages as well, one northeast on Europe and one east on Africa - long path. He is in the process of installing some shorter ones (only 350 feet!) for northwest and south, and then maybe another 900 footer southeast..

#### Radios and Amplifiers:

Steve uses a pair of Icom IC-765 transceivers. The amplifiers include an Alpha-87A, an Alpha 76PA and an Alpha 76. For computers, he has a 486 DX2 and a couple of older 386's. In the TNC department he uses AEA's DSP-2232 as well as a PK-232. Just recently he purchased a P38 from HAL, which now lives in one of his 386's. He has a Timewave DSP 59+ filter and usually uses this audio filter set at 250Hz width . . . and now routinely keeps it in front of the P38. It does a real nice job for getting rid of noise and QRM and helps a lot on the low bands. His Icom 765's have 500Hz filters in them. At one time he had planned on getting 250Hz filters but now that he has a Timewave, he's not sure he needs them. Steve says the IF shift on the Icoms keeps the QRM under control. A scope is available but hasn't found the time to hook it up as yet..

#### Propagation:

The propagation for his area leaves something to be desired and can probably be considered the eastern extremity of the well known "Mid-West Black Hole". They have to fight the guys on the east coast to get through to Europe and Africa. And as we're all aware, they put up one hell of a wall! (But seldom win). They also have to fight the guys on the west coast for Pacific and Japan (and they NEVER win!). A fight is also in order for the guys in the south over the Caribbean, South America and often for Africa, as well as the long path. Steve doesn't feel like they come out on top very often. It takes all the wiles and equipment to try and equalize the playing field just a bit.

#### Favorite Contests:

His three favorite contests are the SARTG, ARRL Roundup and of course , CQ/DJWW. His least favorite is WAEDC because Steve doesn't enjoy exchanging QTC's and doesn't enter any of the WAE contests on any mode. He had a tough time finding contest time last year—out of the country for SARTG and just back a few days before CQ/DJWW. Steve says he didn't have time to get the station organized. So his CQ/DJWW efforts were not great. Numerous visits from dear old Murphy upset the appletart and raised the frustration and stress levels to unacceptable heights. It wasn't fun.

This year? WATCH OUT! (Note: Considering the problems above he still finished 5th World Wide in CQWW '95 RTTY SOH category. That's not to shabby where I come from. Hi! )

As changes are concerned, he likes his top three just the way they are. The question of changing CQ/DJWW RTTY form 30 to 48 hours was contentious but he can certainly live with it either way. His preference would be a 30 hour contest, simply because it's not as hard on the system. He says the 48 hours no off time rule sure separates the casual form the serious operators. Steve says he has never done any Multi operations form his station in RTTY mode, but would certainly be prepared to do so if the right mix of people came together. He has done several Multi operations in other modes several times.

#### Favorite Bands:

His favorite bands are 10 and 15 with 40 close behind. Both parts of 40m (7030-40) and (7080-90) and are checked regularly. Working 80m during tests is enjoyable as long as the QRN isn't too bad. His four-square on this band allows him to work some pretty fair DX on occasions. During a contest he tries to spend as much time as possible on 40 and 80m in the evening. He tries to stay away from 20m as much as possible, because of the crowding, bad manners, PACTOR, BBS and automated station lunacy etc. You will most likely find him on 40 or 80m than 20m but "we all go where the QSO's are," so if it means staying on 20 to keep up the rate, such is life.

#### Techniques:

For RTTY contesting, he does both S&P and CQing. Steve tends to watch his rate and when it drops below 30 per hour, it definitely time to search and pounce. Of course, there are numerous occasions on 40 and 80m, in the middle of the night , where neither works—there just aren't any stations out there. This is where using two radios is particularly important since there are stations which appear for

only short periods of time and then disappear or head back to bed !!

#### Software:

Steve uses RTTY by WF1B but says "Ray WF1B should give a high priority to networking two radios since it really is the future in RTTY contesting. To have to run two "unnetworked" computers, with neither radio supported, is a bit of a pain and really doesn't take full advantage of the technology. CT has been using the networking /two radio approach for years now and it would be nice to see the same for RTTY. Ray has a great product that has single-handedly revolutionized RTTY contesting , but there is still a way to go." It is gratifying that he has been developing upgrades as a result of input, but for reasons that Steve doesn't understand, the WAE contest appeared to have come first. (Note: In the paragraph above, my old buddy Ray WF1B has been flamed a little. I will try and take some of the heat off him. The reason for the WAE test came ahead of networking is the result of democracy in action. PLUS a little SOLICITING of votes—de AB5KD).

I would like to think Steve for his help in preparing this article. I'm sure we will be hearing him during the SARTG and CQ/DJWW contests.

Next month we will visit with Tyler Stewart, KF3P in Damascus, Maryland. Tyler will talk about his efforts to win the Digital Journal's WW RTTY WPX Contest last February. Tyler had to live up to his saying of: NEVER, NEVER QUIT.

#### SARTG & CQ/DJWW RTTY WORLD RECORDS

A complete break down of all records year by year, starting in 1988 for SARTG and 1987 for CQWW, all are listed on WF1B's WWW page, address is: < <http://ids.net/~wf1b/home.html> >



Contest stations on the air - from Spain, EA3AOK

**SARTG RTTY WORLD RECORDS:**

(Cont'd from page 3)

YEAR	C/S	QSO's	PTS	MULTS	SCORE
1992	ZD8LII	505	7565	147	1,112,055 (S/Op: All Band World )
1993	IK1HXN				24,840 ( 80m Record World )
1995	PJ2MI	125	1865	39	72,735 ( 40m Record World )
1994	SMOHTO	401	5045	123	620,535 ( 20m Record World )
1993	ZV2BW				207,080 (15m Record World )
1992	OH1AF				11,300 ( 10m Record World )
1994	F8XT	651	8425	209	1,811,375 ( M/S Record ) Ops: RK9CWA

**SARTG RTTY US/VE RECORDS:**

1992	K1IU	416	5032	174	876,264 ( S/Op All Band US/VE )
1993	VE7SAY				13,200 ( 80m Record US/VE )
1994	K11G	114	1370	40	54,800 ( 40m Record US/VE ) Op: WF1B
1994	WF1B	371	4830	81	391,230 ( 20m Record US/VE ) Op: K11G
1989	W2FCR	201	3055	55	168,025 ( 15m Record US/VE )
1992	NN2G	158	1980	67	132,660 ( 10m Record US/VE )
1993	WA7EGA				831,600 ( M/S Record US/VE ) Ops:WA7EGA,WS7I

**CQ/DJWW RTTY RECORDS:**

YEAR	C/S	QSO's	PTS	ZONES	CTRY	US/VE SCORE
1995	CR9Y	1404	4184	74	217 137	1,791,180 ( S/Op: All Band H.P. World ) ( Op: CT3BX )
1995	K1NG	1375	2711	92	224 181	1,347,367 ( S/Op: All Band Asst. World ) ( Op: K11G )
1995	YV5NFL	918	2706	64	148 150	979,572 ( S/Op: All Band L.P. World )
1994	9A1A	291	622	9	52 16	47,894 ( 80m Record World )
1995	K1IU	674	1227	26	71 54	185,277 ( 40m Record World )
1993	VY2SS	913	2270	27	90 48	374,550 ( 20m Record World )
1992	ZP5JCY	871	2596	30	85 52	433,532 ( 15m Record World )
1992	ZD8LII	840	2503	23	66 53	355,426 ( 10m Record World )
1992	P40RY	2222	6635	91	220 223	3,543,090 ( M/S H.P. Record World ) ( Ops: G0AZT, AA5AU, KP2N, N0FMR )
1995	I2KHM	926	2398	71	192 123	925,628 ( M/S L.P. Record World ) ( Ops: I2KHM, IK2SGF, IK2ZJJ, I2GXS )
1992	W3LPL	2233	4556	116	326 241	3,111,748 ( M/M Record World ) ( Ops: KF3P, N3UN, N3II, WZ3Q, W3EKT, KH2F )

**The next four contests:**

Contest	Dates	Start Time	End Time	Operating Time
CQWW	Sep 28-29	0000 UTC Sat	2400 UTC Sun	No Off Times
JARTS	Oct 19-20	0000 UTC Sat	2400 UTC Sun	No Off Times
WAEDC	Nov 09-10	1200 UTC Sat	2400 UTC Sun	30 of 36 Hrs
SPRINTS	Dec 14-15	2100 UTC Sat	0100 UTC Sun	No Off Times

The Sprints are a fast action 4 hr contest.. It can also serve as a warm-up for the ARRL RTTY Roundup just a few weeks later. Lets all join in the action.

Until next time, 73's de Ron AB5KD

"Remember"

Big antennas high in the sky work better  
than little ones close to the ground..

work is being done and good, new ideas are being generated thanks, in part, to a limited access e-mail reflector which Peter Schulze, TY1PS in Benin has recently set up and made available for IDRA and Digital Journal internal communications. More about all of this shortly.

Everyone is, of course, welcome and encouraged to join and use the IDRA reflector which continues to be well used and monitored.

As always, IDRA is looking for more new members and people who may want to try out specialized software available through the Software Store. When you talk with people on RTTY and on the other digital modes, find out if they know about the Digital Journal, IDRA and the Software Store. If not, make sure you tell them how to find out and how to join up. If you find anyone who is a serious prospect, please send IDRA an e-mail, so we can send him (or her) a sample copy of the Digital Journal with the other sign up information.

73 Paul Richter W4ZB

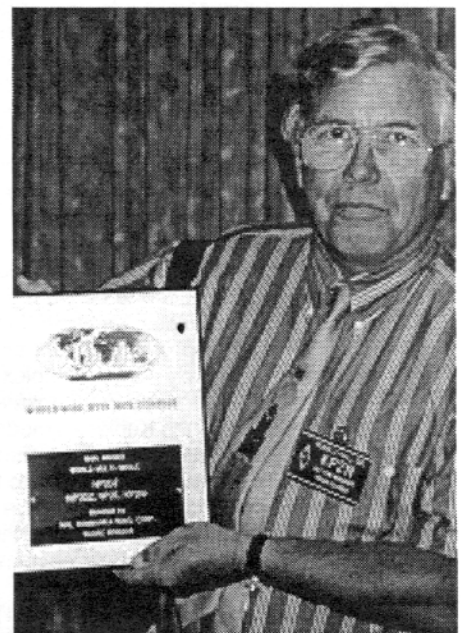

Another contest winner, Ron KP2N proudly displaying his plaque. - Photo by NA2M

# Digital Satellites

How to work 'em and more out of this world info

By David Medley KI6QE/VK2IMJ • 1020 West Oleta Drive • Tucson, AZ 85704  
CIS 74072,1261 / e-mail <davemed@ix.netcom.com>

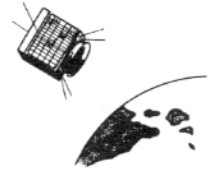

## KEPLERIAN ELEMENTS UNMASKED

astronomers gave to these seven simple numbers and a few related concepts. To make matters worse, sometimes several different names are used to specify the same number. Vocabulary is the hardest part of celestial mechanics!

The basic orbital elements are:

- Epoch
- Orbital Inclination
- Right Ascension of Ascending Node
- Argument of Perigee
- Eccentricity
- Mean Motion
- Mean Anomaly
- Drag

Let us now try and define each of these in an understandable way (hopefully). If you want a more rigorous definition you will have to refer to any text book on the subject which you will probably find in your library.

EPOCH is more easily understood if we say EPOCH TIME. Thus it is a time (and date) on which the Keps are based. If you think of the orbit as a snapshot at a particular time on a particular day of a particular year you will see what EPOCH means.

INCLINATION or ORBITAL INCLINATION is the angle between the plane of the satellite's orbit and the plane of the earth's equator. By convention this number is between 0 and 180 degrees. Orbits with inclination near 0 degrees are called equatorial orbits (because the satellite stays nearly over the equator). Orbits with inclination near 90 degrees are called polar (because the satellite crosses over the north and south poles). The intersection of the equatorial plane and the orbital plane is a line which is called the line of nodes. We will come back to this in a minute.

RIGHT ASCENSION OF ASCENDING NODE or RAAN. This could not be more confusing as a name. Two numbers orient the orbital plane in space. The first number is INCLINATION. This is the second. After we've specified inclination, there are still an infinite number of orbital planes possible. The line of nodes can poke out anywhere along the equator. If we specify where along the equator the line of nodes pokes out, we will have the orbital plane fully specified. The line of nodes pokes out two places, of course. We only need to specify one of them. One is called the ascending node (where the satellite crosses the equator going from south to north). The other is called the descending node (where the satellite crosses the equator going from north to south). By convention, we specify the location of the ascending node.

Now, to complicate matters, the earth is spinning. This means that we can't use the common latitude/longitude coordinate system to specify where the line of nodes points. Instead, we use an astronomical coordinate system, known as the right ascension / declination coordinate system, which does not spin with the earth. Right ascension is another fancy word for an angle, in this case, an angle measured in the equatorial plane from a reference point in the sky where right ascension is defined to be zero. Astronomers call this point the vernal equinox.

Orbital Elements and Nomenclature.

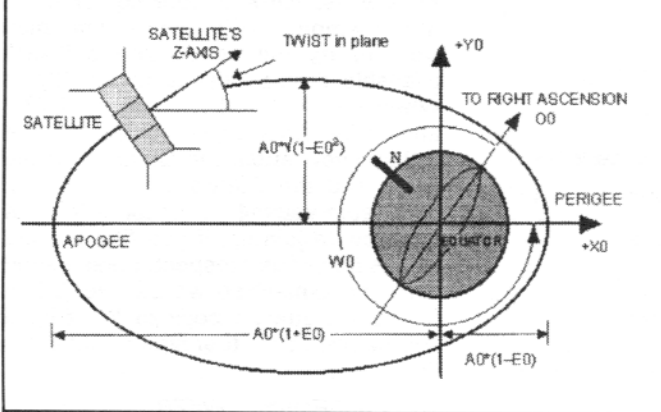

In past articles we have spoken about Keplerian elements, or KEPS as they are often called. These are parameters or numbers which describe in detail the orbit of each satellite in geometrical terms. The name Kepler immortalizes the name Johann Kepler (1571-1630) a famous German astronomer and mathematician of the time. In the early 1600s he established two of the cardinal principles of astronomy: planets travel around the sun in elliptical paths rather than in perfect circles and that they do not travel at uniform speeds. These concepts he formalized in three laws of planetary motion which later lead to Newton's more rigorous general laws of motion.

So today we have developed Kepler's principles to describe the motion of earth satellites. They describe an ellipse about the earth and place the satellite on this ellipse at a given time. These elements are distributed regularly by NASA and repeated on amateur bulletin boards, on the satellites themselves, on Home Pages of the World wide Web and many other places. Entering the numbers into your database is easy and can be automated from data in the satellites themselves and we have talked about that elsewhere. To understand them is more difficult and this article will try and make this a little clearer.

To describe the orbit of a satellite requires seven parameters and for the following discussion you should refer to Figure 1. Seven numbers are required to define a satellite orbit. This set of seven numbers comprises the Keps. In the Keplerian model, satellites orbit in an ellipse of constant shape and orientation. The real world is slightly more complex than the Keplerian model, and tracking programs compensate for this by introducing minor corrections to the Keplerian model. These corrections are known as perturbations. The perturbations that amateur tracking programs know about are due to the lumpiness of the earth's gravitational field (which luckily we don't have to specify), and the "drag" on the satellite due to the atmosphere. Drag becomes an optional eighth orbital element.

Orbital elements remain a mystery to most people. This is probably due first to the aversion many people have to thinking in three dimensions, and second to the strange names the ancient

Finally, "right ascension of ascending node" is an angle, measured at the center of the earth, from the vernal equinox to the ascending node. At this point you are probably lost so lets try an example. Draw a line from the center of the earth to the point where our satellite crosses the equator (going from south to north). If this line points directly at the vernal equinox, then RAAN = 0 degrees. By convention, RAAN is a number in the range 0 to 360 degrees.

ARGUMENT OF PERIGEE or ARGP .This is just another confusing term. Argument is just another fancy word for angle. Now that we've oriented the orbital plane in space, we need to orient the orbit ellipse in the orbital plane. We do this by specifying a single angle known as argument of perigee.

A few words about elliptical orbits. The point where the satellite is closest to the earth is called perigee. The point where the satellite is farthest from earth is called apogee. If we draw a line from perigee to apogee, this line is called the line-of-apsides. (Apsides is, of course, the plural of apsis.) Sorry this is getting complicated again but it hopefully will become clearer. Sometimes the line-of-apsides is called the major-axis of the ellipse. It's just a line drawn through the ellipse the "long way". The line-of-apsides passes through the center of the earth. We've already identified another line passing through the center of the earth: the line of nodes. The angle between these two lines is called the argument of perigee. Where any two lines intersect, they form two complimentary angles, so to be specific, we say that argument of perigee is the angle (measured at the center of the earth) from the ascending node to perigee.

As an example, when ARGP = 0, the perigee occurs at the same place as the ascending node. That means that the satellite would be closest to earth just as it rises up over the equator. When ARGP = 180 degrees, apogee would occur at the same place as the ascending node. That means that the satellite would be farthest from earth just as it rises up over the equator. By convention, ARGP is an angle between 0 and 360 degrees.

ECCENTRICITY or ECC is much simpler. In the Keplerian orbit model, the satellite orbit is an ellipse. Eccentricity tells us the "shape" of the ellipse. When  $e=0$ , the ellipse is a circle. When  $e$  is very near 1, the ellipse is very long and skinny.

MEAN MOTION OR MM. So far we've established the orientation of the orbital plane, the orientation of the orbital ellipse in the orbital plane, and the shape of the orbital ellipse. Now we need to know the "size" of the orbital ellipse. In other words, how far away is the satellite?

Kepler's third law of orbital motion gives us a precise relationship between the speed of the satellite and its distance from the earth. Satellites that are close to the earth orbit very quickly. Satellites far away orbit slowly. This means that we could accomplish the same thing by specifying either the speed at which the satellite is moving, or its distance from the earth. Satellites in circular orbits travel at a constant speed. We just specify that speed, and we're done. Satellites in non-circular (i.e., eccentricity  $> 0$ ) orbits move faster when they are closer to the earth, and slower when they are farther away. The common practice is to average the speed. You could call this number "average speed", but astronomers call it the "Mean Motion". Mean Motion is usually given in units of revolutions per day. In this context, a revolution or period is defined as the time from one perigee to the next. Sometimes "orbit period" is specified as an orbital element instead of Mean Motion. Period is simply the reciprocal of Mean Motion. A satellite with a Mean Motion of 2 revs per day, for example, has a period of 12 hours. Sometimes semi-major-axis (SMA) is specified instead of Mean Motion. SMA is one-half the length (measured the long way) of the orbit ellipse, and is directly related to mean motion by a simple equa-

tion. Typically, satellites have Mean Motions in the range of 1 rev/day to about 16 rev/day.

MEAN ANOMALY or MA. Now that we have the size, shape, and orientation of the orbit established, the only thing left to do is specify where exactly the satellite is on this orbit ellipse at some particular time. Our very first orbital element (Epoch) specified a particular time, so all we need to do now is specify where, on the ellipse, our satellite was exactly at the Epoch time.

Anomaly is yet another astronomer-word for angle. Mean anomaly is simply an angle that marches uniformly in time from 0 to 360 degrees during one revolution. It is defined to be 0 degrees at perigee, and therefore is 180 degrees at apogee. If you had a satellite in a circular orbit (therefore moving at constant speed) and you stood in the center of the earth and measured this angle from perigee, you would point directly at the satellite. Satellites in non-circular orbits move at a non-constant speed, so this simple relation doesn't hold. This relation does hold for two important points on the orbit, however, no matter what the eccentricity. Perigee always occurs at MA = 0, and apogee always occurs at MA = 180 degrees.

It has become common practice with radio amateur satellites to use Mean Anomaly to schedule satellite operations. Satellites commonly change modes r turn on or off at specific places in their orbits, specified by Mean Anomaly. Unfortunately, when used this way, it is common to specify MA in units of 256ths of a circle instead of degrees! Some tracking programs use the term "phase" when they display MA in these units. It is still specified in degrees, between 0 and 360, when entered as an orbital element.

As an example suppose Oscar-99 has a period of 12 hours, and is turned off from Phase 240 to 16. That means it's off for 32 ticks of phase. There are 256 of these ticks in the entire 12 hour orbit, so it's off for  $(32/256) \times 12 \text{hrs} = 1.5$  hours. Note that the off time is centered on perigee. Satellites in highly eccentric orbits are often turned off near perigee when they're moving the fastest, and therefore difficult to use.

DRAG. This is the eighth and optional of the Keps. Drag caused by the earth's atmosphere makes satellites spiral downward. As they spiral downward, they speed up. The Drag orbital element simply tells us the rate at which Mean Motion is changing due to drag or other related effects. Precisely, Drag is one half the first time derivative of Mean Motion.

Its units are revolutions per day per day. It is typically a very small number. Common values for low-earth-orbiting satellites are on the order of  $10^{-4}$ . Common values for high-orbiting satellites are on the order of  $10^{-7}$  or smaller.

Occasionally, published orbital elements for a high-orbiting satellite will show a negative Drag! At first, this may seem absurd. Drag due to friction with the earth's atmosphere can only make a satellite spiral downward, never upward. There are several potential reasons for negative drag. First, the measurement which produced the orbital elements may have been in error. It is common to estimate orbital elements from a small number of observations made over a short period of time. With such measurements, it is extremely difficult to estimate Drag. Very ordinary small errors in measurement can produce a small negative drag.

The second potential cause for a negative drag in published elements is a little more complex. A satellite is subject to many forces besides the two we have discussed so far (earth's gravity, and atmospheric drag). Some of these forces (for example gravity of the sun and moon) may act together to cause a satellite to be pulled upward by a very slight amount. This can hap-

pen if the Sun and Moon are aligned with the satellite's orbit in a particular way. If the orbit is measured when this is happening, a small negative Drag term may actually provide the best possible 'fit' to the actual satellite motion over a "short" period of time. You typically want a set of orbital elements to estimate the position of a satellite reasonably well for as long as possible, often several months. Negative Drag never accurately reflects what's happening over a long period of time. Some programs will accept negative values for Drag but this is generally not considered to be a good idea. It is better to substitute a zero in this case..

Here are some more optional parameters which are not strictly part of the Keplerian Set but are usually provided in the published figures.

Epoch Rev or Revolution Number at Epoch. This tells the tracking program how many times the satellite has orbited from the time it was launched until the time specified by "Epoch". Epoch Rev is used to calculate the revolution number displayed by the tracking program. Don't be surprised if you find that orbital element sets which come from NASA have incorrect values for Epoch Rev. The folks who compute satellite orbits don't tend to pay a great deal of attention to this number. Unless you use the revolution number for your own bookkeeping purposes, you needn't worry about the accuracy of Epoch Rev.

Bahn Co-ordinates or Attitude. The spacecraft attitude is a measure of how the satellite is oriented in space. Hopefully, it is oriented so that its antennas point toward you. There are several

schemes used to describe the orientation of satellites. The Bahn coordinates apply only to spacecraft which are spin-stabilized. Spin-stabilized satellites maintain a constant inertial orientation, i.e., its antennas point a fixed direction in space (examples: Oscar-10, Oscar-13).

The Bahn coordinates consist of two angles, often called Bahn Latitude and Bahn Longitude. These are published from time to time for the elliptical-orbit amateur radio satellites in various amateur satellite publications. Ideally, these numbers remain constant except when the spacecraft controllers are re-orienting the spacecraft. In practice, they drift slowly. For highly elliptical orbits (Oscar-10, Oscar-13, etc.) these numbers are usually in the vicinity of 0 and 180. This means that the antennas point directly toward earth when the satellite is at apogee. These two numbers describe a direction in a spherical coordinate system, just as geographic latitude and longitude describe a direction from the center of the earth. In this case, however, the primary axis is along the vector from the satellite to the center of the earth when the satellite is at perigee.

My thanks to Franklin Antonio, the author of INSTANTRACK, for the inspiration for this article. A fuller description of this topic will be found in the HELP files for INSTANTRACK which is still one of the best tracking programs available for DOS based computers. It is available from AMSAT for a modest donation. Don't forget to join AMSAT and to contribute towards the launching of the new Amateur Satellite next year.

## The PacComm PTC-II

The PTC-II is a new multi-mode controller and "communications platform" which contains powerful and flexible hardware and firmware.

Built in the United States by PacComm under license from S.C.S., the group that developed both the original PACTOR and PACTOR-II.

The PTC-II offers the most robust HF digital protocol available to radio amateurs, but it should not be overlooked that the PTC-II is configurable as a triple-port multimode controller supporting packet data rates of 1200 and 9600 bps and numerous other modes.

- A step-synchronous ARQ protocol.
- Full support of memory ARQ.
- 10 character MODE display, multi-colored LED tuning and status displays.
- Watchdog timer on HF PTT port.
- Specialized communication program provided.
- Firmware contained in Flash memory. Easy upgrade.
- Long-path capability for worldwide connectivity.

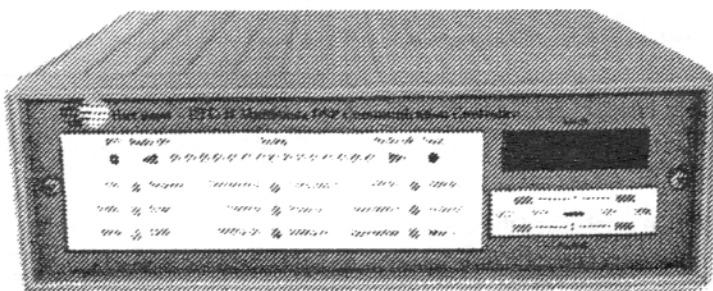

- Full compatibility with PACTOR-I (the original PACTOR), AMTOR, and RTTY.
- Automatic switching between Level-1 (PACTOR-I) and Level-2 (PACTOR-II) at contact initiation.
- All-mode mailbox with up to 32 megabytes of storage.
- Occupies a bandwidth of under 500 Hz - use your 500 Hz CW filters.
- DBPSK modulation yields 200 bps (uncompressed).
- DQPSK modulation yields 400 bps (uncompressed).
- 8-DPSK modulation yields 600 bps (uncompressed).
- 16-DPSK modulation yields 800 bps (uncompressed).

- Independent of sideband; no mark/space convention. Center frequency adjustable between 400 and 2600 Hz to exactly match your radio's filters.
- Differential Phase Shift Keying with two continuously transmitted carriers. 100 symbols per second. Constant bandwidth irrespective of actual transmission speed.

- Powerful Forward Error Correction (FEC): High performance convolutional coding. Constraint length of 9. Viterbi decoding using soft decision point. Coding rate varies between 1/2 and 7/8.
- Intelligent data compression monitors compression ratio and self-bypasses if not being effective. Huffman compression for English or German text. Markov (2 level Huffman) compression. Run-Length encoding for repeated sequences.
- Limited availability. Packet modems available later. \$995. Packet modems are optional at extra cost.

DSP firmware now supports audio filtering.

**PacComm Packet Radio Systems, Inc.**

4413 N. Hesperides Street, Tampa, FL 33614-7618 USA

Switchboard: +813-874-2980

Facsimile: +813-872-8696

Orders/Catalog Requests: 800-486-7388 (24 hr. voice mail)

BBS: +813-874-3078 (V.34)

Internet: [ptc@paccomm.com](mailto:ptc@paccomm.com)

URL: <http://www.paccomm.com/info>



# RADIOAFICION MICROCOMPUTACION

Es una revista publicada bimestralmente en New York desde 1979 en idioma español. La edición de Noviembre/Diciembre contiene anualmente la **GUIA DE EQUIPOS y ACCESORIOS** con las especificaciones de lo nuevo que hay en el mercado. La revista circula en todos los países de nuestro idioma en todo el mundo y contiene cuanto puede interesar al radioaficionado. Los precios de las suscripciones anuales son como siguen. México, Canadá, Estados Unidos y Puerto Rico: 25 dólares. Para los demás países de nuestro Continente: 45 dólares. España, Lejano y Cercano Oriente: 50 dólares. La revista se envía en sobre cerrado por vía aérea al domicilio del lector. Precio de la **GUIA PRACTICA PARA SATELITES**, Segunda Edición. América Latina incluyendo el franqueo aéreo: 22 dólares. España, Lejano y Cercano Oriente: 25 dólares. Estados Unidos, Puerto Rico, México y Canadá: 20 dólares. Los pagos deben hacerse mediante cheque de cuenta bancaria en Estados Unidos, cheques de viajero o giro postal a nombre de:

**PAN AMERICAN PUBLISHING CO.**  
252-35 Leeds Road  
Little Neck, NY 11362  
Estados Unidos de América

No se aceptan tarjetas de crédito ni cheques de otros bancos fuera de Estados Unidos.



# COMMUNICATIONS

Make the Connection  
with

## FLORIDA SKIP Magazine

Amateur Radio - Computers  
Digital Techniques  
News - Information - Features  
Net News - Club News - Traffic Reports  
QCWA, KOTK, OOTC, MARS, ARRL  
Hamfests - Fleamarkets - FCC Actions

- What's on Internet/World Wide Web?
- Privacy issues in communications.
- Government regulations vs. amateur radio & computers.
- What is the clipper chip?
- ECPA and you.
- How secure is E-mail?

Read about it in:

*Florida Skip*

672 Indian River Dr., Melbourne FL 32935  
ONLY \$12/yr - Write for sample copy  
Phone/Fax 800-421-3279

### Amateur Radio Trader™ ....The Ham Radio Market Place.™

Join ham radio's most revolutionary happening since the no-code license!

- Hundreds of radios, products and services
- Current pricing and availability
- Low subscription and ad rates
- 250+ classified headings
- Major credit cards accepted
- It's like holding a hamfest in your hands!

Call **Amateur Radio Trader** today to be a part of amateur radio's most comprehensive resource for equipment and other products and services.

For immediate service call toll-free (USA and Canada)

**1-800-774-2623 or fax 1-800-423-9030.**

Internationally, call

**615-484-5137 or fax 615-484-2532**

YES! Please start my subscription to:

**Amateur Radio Trader, The Ham Radio Marketplace.**

Subscription rates for one year (circle preferred rate):

Third class \$14.95 (just \$.62 per issue)

First class \$34.95 (just \$1.46 per issue)

Name \_\_\_\_\_

Call Sign \_\_\_\_\_

Address \_\_\_\_\_

City \_\_\_\_\_

State \_\_\_\_\_ Zip \_\_\_\_\_ Phone (\_\_\_\_) \_\_\_\_\_

( ) Check or money order Charge my ( )  VISA ( )  M/C ( )  Exp. \_\_\_\_\_  
Credit Card # \_\_\_\_\_

Complete, clip and mail this form to: Amateur Radio Trader - 410 West Fourth Street  
P.O. Box 3729 - Crossville, TN 38557

All rates subject to change without notice.



# The Last Word

from the Editor

Jim Mortensen, N2HOS • PO Box 596 Somers, NY 10596-0596.

CompuServe ID: 71573,1077 • E-mail <jem@n2hos.com> • 914.276.1058 • fax: 914.276.1059.



**Changes are on the way.** First came the membership survey; then came the input from the Digital Journal staff; then the intensive electronic discussion; and finally the decisions. Let's review some of the changes. And then look at the mechanism that allowed all of this to happen so fast.

**First, count on three special issues each year!** From now on, every January issue of the Digital Journal will be primarily devoted to the subject of Contesting, the May issue to Operations and the September issue to DX. Ron AB5KD produces the Contest issue, Neal ON9CNC Operations and Don AA5AU DX.

The Contest issue will include, tucked in among several articles of interest, all of the rules for all of the known contests for the year ahead. Can't find the January issue in September? Fret not. Go to the Digital Journal website and download the zipped file in either .wri or .txt format (<http://www.n2hos.com/digital/software.html>). Better yet, buy a floppy from the Disk Library. There will also be a full page calendar of contest events for the whole year. Put it up on the wall of the shack and then plan your vacations and domestic commitments accordingly.

The Operations issue will coincide with Dayton 1997, the first time around. This is by design, for it has long been felt that we reach more beginners or first-time lookers at that particular time than any other. So, the editor in charge chooses to concentrate on those subjects most in demand—beginner's RTTY (and Amtor, Pactor and Clover), Contesting, DXing, antenna-building, software, hardware, etc.. Leave it to Neal!

September kicks off the DX season as we leave the summer months and get ready for the winter's spike in propagation (Don will tell you of course that this summer's DX has been pretty spectacular). This is perhaps the most interesting assignment because of the nature of DX news. Much of it has 'gone electronic,' never to return to the classic DX Newsletter format. So, what does a magazine do? Watch and see how the man from the bayou tackles this project in the September 1996 trial balloon. This will be our first special issue, one for which we have very little preparation time. In the meantime, read Don's columns and watch his comments on the website.

**There's more than meets the eye.** Much more has been determined as well. One of the most contentious issues has long been the reporting of contest scores. Everything from timing to format to quantity to type size has been an issue. No more. The Digital Journal will now proceed as follows: 1) as soon as possible after any one of the scheduled contests, High Claimed Scores will be posted on the Journal's website, 2) official results for all digital contests will be published in full as soon as possible after the release of the scores by the contest manager. Contest commentary will be released in the same issue, 3) after publication, the full official results will be posted on the Internet. That takes care of contest scores.

What about the rest of the magazine? As we agreed, "the balance of the Journal's coverage will be balanced . . . between the three forces residing on the desktop of virtually every digital ham. To the left, there is the transceiver and related gear. At the center, there is the surprisingly powerful computer. To the right, there is the telephone connection and all it repre-

sents. Our members, based on everything we know, need help in all three areas. And it is undeniable that any operator must be master of all three if he or she is going to be successful at DXing, Contesting or plain QSOing."

Enjoy the changes. Hopefully you will agree with the Digital Journal staff and call them improvements as well!

Though most of us involved in this discussion and the subsequent decision-making process were at Dayton, there was no space on the calendar for this sort of reflection. Too many other events intervened. But then Peter TY1PS came to the rescue. His firm acquired a block of Internet capacity that was considerably beyond their need. So, said he, 'Let's set up a reflector for IDRA directors.' And he did. I said, 'Why, if you have all that space, not set up a reflector for the Digital Journal staff as well.' And he did. Within 48 hours or so we had 23 of the staff linked. Only two remain 'unwired.' (WA3ZKZ wired up on 7/15/96!)

A reflector is a giant magnifier of messages. If I, for example, send a message to the reflector, the message is automatically 'reflected' to the 21 other members of the staff. Anyone who replies to that message sends the reply to the 21 others as well. Neither of us lifts a finger to accomplish this mass distribution. Needless to say, this generates a very high volume of digits! Messages streaked back and forth. Most were positive inputs. Some verged on being flames. More than half of the staff participated, a few of them generated over half the volume (ratios about equal to any random group such as this), one asked to be disconnected! There were heated moments but no blood shed, no broken bones, no lost friends. And it was fast and productive. The reflector became a vital link very early on. Thanks Peter.

**I have to tell the story!** Yes, I know. What they call anecdotal evidence is virtually worthless in a court of law . . . and not of much more value in a serious research project. I do not mean to imply by relating this story to you that amateur radio is dead, or that the Internet is taking over the world, or any other such nonsense. It's just an interesting anecdote and does tell us what is happening to many of us, regardless of age or background.

When I am in New York I have breakfast every Thursday morning at 0800 local with a group of old friends who just happen (with one soon-to-be-corrected exception) to be hams. It's about a fifty mile round trip to be with the old neighborhood gang so you know that it is a worthwhile experience, every week. Now some of these folks have been around a long while. I won't give away any ages, but one of them has been licensed and active for 66 years, another well over 50! Except for the WWII era, they have been on the air as regularly as clockwork.

Two weeks ago, the gentlemen who was licensed in 1930 came prancing toward our round table in the corner of the diner, all smiles even after his 20 mile drive, holding a piece of tractor-feed computer paper in his right hand. Seems that he had just received a message that morning from his friend in Moscow, a ham who is a staff member at a European embassy there. This friend had just been transferred to Melbourne, Australia and was about to leave after his typical three-year

tour of duty. I mistakenly assumed that he was informing others who had known him during his New York tour some years back and thought no more of it.

One week later, the same scenario, except that this time he sat down next to me. After showing me the message from Moscow (very interesting because it happened to be right after the Russian run-off election), I suddenly realized it was an E-Mail message picked off the Internet barely an hour earlier. It was at that moment that he began expounding on the wonders of E-Mail . . . how he had sent a message to Moscow the night before and here was the answer as soon as he got to the computer this morning. Yes, I had heard that before. But he pressed forward. Seems that he had met his correspondent in New York several years ago on a 75meter phone net. They got acquainted, exchanged family visits and my friend followed them via ham radio as they went to Tanzania and then, as I recall, to Peru.

"In those days," he said, "propagation was so good that we could stay in touch on a regular schedule. But we have never made a connection from here to Moscow and surely won't in Melbourne. Maybe propagation will come back before he leaves Melbourne in three years, maybe not. But in the meantime there is nothing like E-mail. I don't use the rest of the Internet yet because I only have this 286 my son gave me . . . and set up for me. He's on the Internet a lot and has a lot of computers."

You know as well I do what is going to happen next. Either the son will upgrade to a new Pentium supremo and let his 486/66 trickle down to good old Dad; or Dad, on his own, will fork over the thousand-or-so bucks it takes to do it all. His son will help him set it up either way, of course, and get him surfing with a browser. (And maybe get him to try something other than VHF packet, maybe even RTTY!). There seems to be no way to avoid this chain of events leading first to Dad's hardware upgrade, through the trying period of his education and orientation, and finally to that glorious moment when he is off on his own for good. Don't, for a minute, think that the difficulties inherent in such a transition will in any way slow down this gentleman's advance. After all he has been licensed all these 66 years!

Since I have now witnessed this series of events at least a half dozen times during the past year or so, I am convinced it is a trend. We'll call it the 'hardware trickle down' phenomenon . . . and be close to the truth. There's no moral to the story, and it does not suggest that the Internet will replace ham radio. It just proves once again that good hams communicate whatever the circumstances, however large the obstacles, by taking advantage of their surroundings, used parts, current technology and available equipment.

**Once upon a time** . . . there used to be a lot of RTTY noise on 20 meters during the early evening hours (Eastern time). Principal among the players was a lady called Barb who signs N4LIH. Other very familiar callsigns joined in the round-robin and, quite regularly, all four corners of the US and some interesting DX calls were in attendance as well. Anybody could and would join in and all were welcome . . . yes even beginners. A great time was had by all. But then it disappeared, as suddenly as good television shows went bye-bye in prime time!

Oh, let's see, Barb's antenna got a bit of mistreatment from one of those funny little Florida windstorms, propagation took a dismal turn, other modes beckoned some of the regulars, and perhaps some simply tired of the nightly ritual. Whatever, it has been a quiet time on that part of the band for some time now. There have been some recent attempts to restart that habit, to fill 20 meter RTTY with lots of good conversation. And now there is a new urgency to that effort.

You see, Barb is coming back. Yesterday, among the pile of

daily messages from the Internet was one from N4LIH. She's 'RTTY homesick,' is rejoining the Digital Journal gang and wants to get the fires going on 20 meters. Most of the messages I received yesterday didn't amount to a pot of beans, but this little gem hit home . . . and I'll tell you why.

Barb, after OM Gary got her up and running on the Internet, found the Digital Journal website and, says she, "I spent over an hour reading everything there." That's when she got homesick, that's when she decided to 're-up' her membership, that's when she decided to get back into the thick of things and get back on the air. I can ask no more. Keeping that damned website up to date is about three times as frustrating (I know, it's a learning experience!) as I had assumed and about five times as demanding in terms of time! A message like this one, though, makes it all worthwhile. I trust there may even be a few other lost souls out there just looking for an excuse to return to the keyboard. Help them find the page if you have a chance, and bring them back to the right stuff. At any rate, it will be a delight to get the round-robin chattering again.

Wouldn't you know it. Within hours of writing the above paragraphs, I moved across the room to my rig, tuned up my big antenna in the attic and dialed around to see what was going on. I called CQ in Clover and had a chat with Jim KA6A (who is the newest Digital Journal staff member, more later). Then I switched over to RTTY, worked a '3' call, then joined a minipileup and tried for the HK3. That took a lot of nerve . . . me and my 50 watts and a little piece of copper pipe in the attic! The HK answered a kilowatt from 4-land and I dialed up a bit further and heard, believe it or not, AA5AU calling me! "Hey," he said, "you are 10 over S9 down here in the bayou." "Don," I said, "flattery will get you nowhere!" He swears it was true and we did have a (pardon the expression) copper pipeline between us and had a good QSO and the signal was solid throughout. After signing, I tuned around a few more minutes and there was WS7I. Jay was a weak signal off the end of my dipole so we didn't make it, but these are solid signs that the 20 meter evening club is starting up again. Give it a try! See if you are the first one on your block to work that guy up in Somers, NY who has the only copper pipe dipole around.

**Welcome Jim KA6A to the staff.** Jim and I had a good conversation during one of the quiet hours in the hospitality suite in the Radisson last May. He is a professor in the real life, involved in things called semiconductor lasers. While he is not involved professionally in propagation he has made quite a study of the subject and the requisite tools involved in forecasting. So, guess what, he will start a long series of articles on that subject in the September issue.

He has made propagation work for him. His DX record speaks to that—only needs P5 to have worked them all on Mixed and P5 and Heard for the same in CW. Nothing to be ashamed of there. We welcome Jim and look forward to his contribution to one of our more important subjects.

**Short notes:** AEA has discontinued tech support on CompuServe as of late June. While they now have a website at <http://www.aea@aeainc.com>. No tech support will be available there, however. Call 206 775 7373 or fax 206 775 2340 for support.

Note also that you can now download the Help files for Express 3.62 in US letter format (for printing) at <http://dtsdata.intenet.bj/updates.htm> or from <http://www.n2hos.com/digital/software.html>. This will give you a handy paper reference to the many features of the program.

A final note of thanks to Bolin BV5AF for his timely update on Taiwan. We do appreciate it.



# Right On Target

## CLASSIFIED AD DEPARTMENT

First 30 words \$7.50, additional words 10 cents each. Cash with Ad. Deadline for ads is the 5th of the prior month of publication. (Example - Ad arrives by the 5th of December, will appear in the December issue.)

**NEWS - NEWS - NEWS - NEWS . . .** Amateur Radio's Newspaper "WORLD RADIO". One year subscription (12 issues) \$14.00 for U.S., non U.S. \$24.00, 2 Year subscription (24 issues) \$27.00 U.S., non U.S. \$47.00, 3 year subscription (36 issues) \$39.00 U.S. non U.S. \$69.00, Lifetime subscription \$140.00 U.S. non U.S. \$240.00. Contact: WORLD RADIO, P.O. BOX 189490, Sacramento, CA 95818

**CQ Magazine, The Radio Amateur's Journal** —If you enjoy ham radio, you'll want CQ. Published monthly, CQ brings you the best writers for some of the finest reading in Amateur Radio. Subscribe now and save up to 35% OFF newsstand prices! One year \$24.50 U.S., \$27 Canada/Mexico; Foreign Air Mail \$82. Contact CQ Communications, Inc., (also publishers of Popular Communications, ComputerCraft, Electronic Servicing & Technology and numerous amateur radio books/videos), 76 North Broadway, Hicksville, NY 11801, Phone (516) 681-2922 or FAX (516) 681-2926.

**BACK ISSUES** - All Back Issues of the Following: RTTY Digital Journal - ATVQ - A5 SPEC-COM & ATV TODAY. Write for list & prices - SASE - ESF Copy Service, 4011 Clearview Dr., Cedar Falls, IA. 50613 (319) 266-7040

**RTTY CONTEST SOFTWARE:** This is the program used by WINNERS. RTTY by WF1B is the premier teletype contest software. Supports CQWW, ARRL, SARTG, BARTG contests. New DXpedition mode recently used by AHIA. Supports HAL PCI-3000, PK-232, KAM, MFJ-1278, UTU, AMT-1, and Standard TUs. Online features: Automatic duping, Automatic multiplier identification, Automatic scoring, Mouse support, Break-in buffer, Buffer tags for dynamic custom transmissions, File transfer. Post Contest features: Complete paperwork generation, QSL labels, Statistics. Call (401) 823-RTTY for fact sheet. IBM-PC, \$45.95 (US/VE) \$49.95 (DX). Specify disk size. Wyvern Technology, 35 Colvintown Road, Coventry, RI 02816-8509

**DSP MODEM:** RITTY 1.0 is a high-performance software modem that runs in your PC and uses your sound card. RITTY uses a limiterless front-

end, optimal matched filters, automatic threshold correction, numerical flywheel, and other advanced techniques to recover RTTY signals ordinary modems can't copy. RITTY features a graphical FFT tuning indicator that's better than a scope, demodulated-signal display, signal-timing analysis, adjustable mark/space frequencies, precision AFSK, FSK/PTT outputs, and pop-up menus. RITTY supports RTTY by WF1B. 386/40 or better, math coprocessor, Sound Blaster 16, and VGA required. \$100. Add \$5 overseas. Visa, MasterCard, Discover, U.S. check, cash, or money order. Brian Beezley, K6STI, 3532 Linda Vista Dr, San Marcos, CA 92069. (619) 599-4962. k6sti@n2.net. 9/96

**FOR SALE: TOSHIBA 6600CD** luggable/portable. Runs on 115VAC or 230VAC with auto sensing and 50/60Hz auto sensing. 486-66 CPU with 16MB RAM/8MB on PC card. Graphic accelerator. Full function, movable 101 key keyboard with port for external keyboard. One 1.44 floppy. Active matrix display with port for SVGS/VGA monitor and simultaneous display. BIOS in flash ROM. Toshiba 4X CD. Also includes a Ditto backup tape system and 6 Travan tapes. Over two years left on original 3 year warranty. Microsoft Sound System with 2 built in stereo speakers. Microsoft microphone. Logitech Trackman pointing device. Windows 95, MS Office Pro and other software installed. All manuals. Room for 2 full length ISA cards. Practical Peripherals 28.8 modem with EZ way connection. 510 MB hard drive. PS2 mouse port PCMCIA slot. Audio line in and out; microphone jack, headphone jack. Volume control in front. Perfect condition. \$2,200. If interested, contact Al Matlick at matlick@gate.net; 941-923-7008 or 3835 Alamanda Drive, Sarasota, FL 34238-4578.

**FOR SALE:** My HAL ST-8000 TU/Modem needs a good home. In like-new condition. unparalleled in performance for HF/VHF/RTTY, Amtor, packet, etc. Computer programmable and frequency agile, handles virtually any tones and shifts, ultimate for contesting, dxing or casual digital communications. Sold new at \$3495.00, asking \$1700.00. Will consider partial trade for dual band VHF/UHF mobile or HT. Also HAL ARQ1000B \$600.00. Al, N4VF (919) 880-9958 days/eve., also e-mail <aclement@microspace.com>

**Is it time to renew your subscription/membership? Be sure to check your mailing label!**  
New or Renewals. Please fill out and mail form below with appropriate payment to:  
**IDRA/Digital Journal • P.O. Box 2550 • Goldenrod, FL 32733-2550**



Please forward my annual membership in the International Digital Radio Association (IDRA) and subscription (12 issues per year) to the *Digital Journal* - immediately!



**Please check the appropriate boxes and enclose payment (in U.S. FUNDS ONLY):**  NEW  RENEWAL

- 1 Year:  \$25 U.S., Canada, Mexico  \$32 1st Class-North America/Surface-DX  \$42 AirMail - DX
- 2 Year:  \$47 U.S., Canada, Mexico  \$60 1st Class-North America/Surface-DX  \$78 AirMail - DX
- 3 Year:  \$68 U.S., Canada, Mexico  \$85 1st Class-North America/Surface-DX  \$114 AirMail - DX

Contribution \$ \_\_\_\_\_ IDRA Non-Profit status could make your contribution fully tax deductible.

Credit Card  Visa /  MC # \_\_\_\_\_ Exp. Date \_\_\_\_\_ Signature \_\_\_\_\_  
(For faster service, credit card orders accepted by phone. Fax your order to IDRA at: 407-671-0194)

Name \_\_\_\_\_ Call \_\_\_\_\_

Address \_\_\_\_\_

City \_\_\_\_\_

State/Country \_\_\_\_\_ Zip/Postal Code \_\_\_\_\_ - \_\_\_\_\_

Internet or other On-Line Address(s): \_\_\_\_\_ Age: \_\_\_\_\_



# SOFTWARE STORE



IDRA • PO Box 2550 • Goldenrod, FL 32733-2550

Tel: 407/677-7000 • Fax: 407/671-0194

## SOFTWARE

**EXPRESS 3.62** - (Windows 3.11 or above). Best Clover control program available - also handles Pactor, Amtor & RTTY. Sends digitized pictures and compressed voice, video and data. Run a full Clover BBS. Full duplex. Does it all while maintaining keyboard QSO. Requires HAL PC14K, DSP4100 or HAL P38; 486xx + 8mb RAM.. Available exclusively from IDRA for \$60.00; UPGRADE from 2.x: \$30.00; UPGRADE from 3.5: \$15.00. By TY1PS.

**RTTY by WF1B** - DOS program. For most TNCs. Ultimate contesting tool for novice and expert. Supports all major RTTY contests and Dxpeditions. Features include automatic call sign capture, dupe checking, country & multiplier identification, mouse support and much more. \$49.95.

**LOG-EQF** - Brand new version 8.0 now shipping. Complete computer based logging system . . . and control center for on-air activity. Easy logging, data terminal, DX Cluster, rig control, beam headings, QSL labels, DXCC & WAS info and much more. A DOS program but optimized for Windows. Available in two versions:  **Log-EQF \$39.95** or  **LOG-EQF-JR** (\$25.00) Jr. is identical without the radio and TNC interfaces. Registered users also get FILE-EQF, WAS-EQF and DX-EQF - the file utilities for record keeping. By N3EQF.

**RIG-EQF** - Have your computer control your Kenwood rig. Various parameters can be controlled and monitored via your computer increasing the power and flexibility of your station. Includes large digital display. Sophisticated, programmable scanning and much more. \$20.00.

**RagChew** - Windows software for HAL PCI 4000 or P 38 cards. Developed by Jim Jennings, KE5HE, to take full advantage of your HAL card. Send/receive RTTY, AMTOR, PACTOR and ASCII all from the same friendly, easy to use screen. Requires Windows 3.0 and DOS 6.0 or higher. Available only with embedded call sign. \$30.00.

**PakTERM** - Here is how to take your PacComm PTC to the its limits. Makes your life easier with an assortment of automated features. There is no better DOS based PTC terminal available. Only \$30.00. By AA4PB.

**SNAPmax** - New & improved version of the famous SNAP DX propagation software. Makes finding a radio path that is open at a specific time and frequency a snap. No more guessing. Just call up SNAPmax. By WA3ZKZ. Exclusively from IDRA for \$40.00 (\$25.00 for upgrade from SNAP).

## BOOKS

**BASIC PACKET RADIO BOOK** - (2nd Edition) - In this edition you will find updated information based on based on readers comments. A chapter on operations via the Internet, Wormholes and LAN-LINK 2.30 documentation. What is packet radio. How to use it. LAN & PBBS information. Using nodes, Packet Clusters, servers. LANLINK manual and evaluation diskette. \$29.95.

**RS232C & COM PORTS Booklet** - If you use a computer in conjunction with ham radio, you will find this an invaluable tool to have in your shack. Contains information on COM Ports 1,2,3,4 and RS-232C. \$5.00.

**NOW . . . Get all 1995 issues of the DIGITAL JOURNAL ON 3.5" Disks**  
(One month per disk in Adobe's PDF format)

<b>Order:</b>	
<b>1 Month</b>	<b>\$4.95</b>
<b>3 Months</b>	<b>\$12.95</b>
<b>6 Months</b>	<b>\$19.95</b>
<b>12 Months</b>	<b>\$34.95</b>

**All orders include FREE Viewer**  
Add \$3.50 for S/H

## \$5.00 SOFTWARE SPECIALS

Order any of the following programs for only \$5.00 including FREE S/H

- Winlink** : the classic HF BBS software
- Lan-Link 2.45** : Joe Kasser's latest all-mode tnc program
- HYLOG** : the latest version of this basic logging program
- Excel DXCC Template** : Don AA5AU's creation
- RITTY Demo** : Brian K6STT's software TNC for 16bit S/B
- HAL Files** : the May 20, 1996 version is now shipping.
- Scan - ver. 1.15** : New release. Requires RS232 interface. All units must upgrade

ITEM(s) ORDERED

PRICE

\_\_\_\_\_

\_\_\_\_\_

\_\_\_\_\_

\_\_\_\_\_

Mail to  
**IDRA / Digital Journal**  
**PO Box 2550**  
**Goldenrod, FL 32733-2550**  
 with your check or money order payable  
 in U.S. Funds ONLY  
 or FAX to 407-671-0194.  
**--Master Charge and Visa accepted--**

\_\_\_\_\_

\_\_\_\_\_

\_\_\_\_\_

\_\_\_\_\_

Disk Size: 3.5"

Shipping & handling, U.S./N.A.: \$2.50 / DX: \$5.00 Total \$ \_\_\_\_\_

Note: Credit Card orders require minimum purchase of \$25.00

VISA \_\_\_\_\_ Master Card \_\_\_\_\_ Number # \_\_\_\_\_ Exp Date \_\_\_\_\_

Name \_\_\_\_\_ Callsign \_\_\_\_\_ Signature \_\_\_\_\_

Address \_\_\_\_\_

City \_\_\_\_\_ State/ Country \_\_\_\_\_ Zip or Postal Code \_\_\_\_\_

# The New Leader In Satellite Communications!

*and digital*



## IC-820H FEATURES:

- Built-in Auto Satellite Functions
- All Modes in a Compact Case (9.5" W x 2.7" H x 10.0" D)
- "Plug and Play" 9600 bps Operations
- Built-in High Stability Crystal ( $\pm 3$  ppm)
- Independent Controls with Sub Tuning
- New DDS for 1 Hz Resolution
- IF Shift (electronically shifts for effective interference reduction)
- Satellite Memory and Tracking Function (rev./normal tracking on main/subband)
- Doppler Compensation Function
- 10 designated Satellite Memories
- Data Jack for Packet Ops. (9600 bps)
- New Modulation Limiter Circuit
- 2 VFO's each for VHF and UHF Bands
- 50 Memory Channels
- Stereo Headphone Jacks
- 2 Antenna Connectors
- Noise Blanker
- RIT Function
- Memory Allocation Function
- Attenuator
- Programmed/Memory/Mode Select Scan
- CW Semi-Break In and Side Tone
- AF Speech Compressor (audio)
- Auto Repeater and One-Touch Functions
- Separate Main and CW Filters
- CW Narrow Filter (optional)
- Tone Scan (optional)
- 45 W (FM, CW), 35/6 W (SSB) VHF
- 40 W (FM, CW), 30/6 W (SSB) UHF
- Microphone Optional

## IC-820H 2 M/440 MHz Dual Band All Mode Transceiver

*The IC-820H isn't your typical base station transceiver. This all mode dual bander has compact and lightweight dimensions offering operating versatility other base stations just can't match. Mobile and field operations are ideal with this rig. But don't let its size fool you. This is a high performance transceiver with state-of-the-art construction, circuit design and cutting edge features.*

ICOM's Newly Designed I-loop DDS (digital direct synthesizer) is employed in the PLL circuit of the IC-820H. Previous PLL circuits for 10 Hz resolution transceivers contained 2-loop circuits. The new I-loop has a single loop and Generates a Signal with Superior 1 Hz Resolution. ICOM's DDS PLL also contains a normal PLL as the main-loop and a DDS as the sub-loop.

Satellite operation with the IC-820H's Built-In Satellite Functions has never been this easy. These include Normal and Reverse Tracking for different modes of satellite communications; Independent Uplink/Downlink Control for Doppler shift compensation; Separate Satellite VFO and 10 Dedicated

Satellite Memories provide quick switching from normal to satellite operation as well as easy recall of satellite and downlink frequencies.

With Independent Controls and Indications for Both Bands, this dual bander is as easy to operate as most single band transceivers – and exchanging the main and sub bands is just a switch away. Separate 5-Meters simultaneously indicate each band's respective signal strengths.

The Sub Tuning Function can be assigned to the RIT or SHIFT control and allows you to tune automatically at variable tuning speeds. This is especially useful when searching for signals over a wide frequency range – eliminating the need for excessive rotations of the main dial.

The IC-820H's Compact Size enables easy installation in a shack as well as a vehicle. Overall dimensions may be small, but important points such as LCD size and space between switches are more than adequate.

An important consideration in all mode transceivers is the interference reduction circuit. The IC-820H's

IF Shift Circuit electronically shifts the center frequency of the receiver passband to evade interfering signals.

The IC-820H's DATA Terminal (in ACC socket) is connected to its modulator circuit directly. This Data Jack supports Packet Operation at up to 9600 bps. A newly designed Modulation Limiter Circuit prevents you from exceeding the maximum deviation – even with large amounts of data.

For more information about the IC-820H, visit your local ICOM dealer, contact ICOM Technical Support in the HamNet forum on CompuServe® at 75540,525 (Internet: 75540.525 @ compuserve.com) or

call ICOM's  
brochure hotline:  
(206) 450-6088.



© 1995 ICOM America, Inc. 2380-116th Ave N.E., Bellevue, WA 98004. The ICOM logo is a registered trademark of ICOM, Inc. All stated specifications are subject to change without notice or obligation. All ICOM radios significantly exceed FCC regulations limiting spurious emissions. CompuServe is a registered trademark of CompuServe, Incorporated, an H&R Block Company. B20H696Y

*Experience the Quality*

**ICOM**

# Digital Communications As Easy As 1,2,3 *With* The Most Affordable Multimode *DSP* Modem This Is Your Connection To The Digital World

# P38

**1 INSTALL P38 & SOFTWARE**

**2 CONNECT FOUR CABLES**

**3 WORK THE DIGITAL WORLD**

**LARGE SOFTWARE SUPPORT LIBRARY AVAILABLE NOW!**

- EXPRESS CLOVER
- FACTOR
- BAUDOT
- ASCII
- BBS NETS
- RAG CHEW
- DX CONTESTS
- IMAGE FILES
- DIGITAL VOICE
- HAL P38
- ERROR FREE
- HIGH SPEED
- WEAK SIGNAL
- WORK ALL MODES & DATA TYPES WITH TOP PERFORMANCE.
- FUTURE

**All of these modes with DSP performance for only**  
**\$349.95**  
 Amateur List

**Operates CLOVER, AMTOR, PACTOR, and RTTY  
CALL OR FAX THE HAMS AT HAL  
MIKE, W9KVF OR MARK, WB9HFK**

**PHONE (217) 367-7373 FAX (217) 367-1701**



**HAL Communications Corp.**  
**P.O. Box 365**  
**Urbana, IL 61801 USA**  
**E-Mail: halcomm@prairienet.org**

