

DESCRIPTION, ADJUSTMENTS, AND ORDERING INFORMATION
TELETYPE MODEL REC-32 RECTIFIER

Description

The Model REC-32 rectifier is designed to provide direct current that is suitable for the operation of apparatus such as the Wheatstone perforator when the rectifier is operated from A.C. sources of various voltages and frequencies. This direct current, however, is not suitable for use in the signalling or local relay and selector magnet circuits of Teletype apparatus. The input requirements and output rating are as follows:

Input: 95,105,115,125,190,210,230, or 250 volts, 25,40,50, or 60 cycle, single phase A.C.

Output: 1.2 amperes at 120 volts D.C. (no load voltage of a new rectifier should not exceed 150 volts).

Maximum A.C. component in D.C. output voltage 3 volts (r.m.s.) at 1.2 ampere load.

The rectifier consists essentially of a transformer, a full wave selenium rectifying assembly, a choke coil, filter condensers, a bleeder resistor, a terminal panel, output fuse, input power switch, input cord with plug, and output cord with receptacle. The parts are secured to a metal base which is provided with feet for shelf mounting. The metal cover has expanded metal panels for ventilation, and a hinged door provides access to the control panel and fuse.

The primary winding of the transformer has one set of taps that terminate at the bottom of the control panel and provide for input voltages of 95,105,115,125,190,210,230, and 250 volts at 25,40,50, and 60 cycles A.C.

The secondary of the transformer is provided with taps so that the output voltage of the rectifier can be adjusted to suit requirements and to compensate for the aging of the rectifying assembly. Three taps that provide coarse voltage adjustment are marked "L," "M," and "H" and five taps that provide fine voltage adjustment are marked "1," "2," "3," "4," and "5." These taps are wired to terminals at the top of control panel. Connections to these terminals are made by means of flexible leads.

The input and output cords terminate on the left-hand side of the control panel. The double pole switch disconnects both sides of the input line from the entire rectifier, with the exception of the two input terminals on this panel, when the switch is in the "off" position. The cover must be removed to gain access to the terminals on this panel.

The approximate dimensions of the rectifier are as follows: 18" long 8" deep, and 10" high. The approximate weight is 50 lbs. The metal cover, which is fastened to the base by means of screws, is finished in black wrinkle enamel.

The actual and theoretical wiring diagrams of the rectifier are shown on WD-2192. An assembly drawing showing names and part numbers of the component parts of the rectifier is also furnished.

Adjustments

Move the power switch to the "off" position and open the hinged door in the rectifier cover.

Caution: The secondary voltage of the transformer is (approximately) 200 volts. Do not make any adjustments while the rectifier is in operation.

1. To adjust for A.C. input voltage, connect the flexible lead on the bottom of the control panel to the terminal with the marking which most nearly corresponds to the voltage of the available A.C. supply.
2. To adjust for D.C. output voltage, connect two 60 watt 120 volt Mazda lamps in parallel and then connect this lamp load in series with a suitable ammeter across the D.C. output of the rectifier. Connect the flexible leads located at the top of the control panel to the terminals (marked L, M, H, and 1,2,3,4, and 5) which cause the milliammeter to register a current flow which is nearest to but not less than 1 ampere.

This adjustment should be checked when the rectifier is installed and periodically thereafter. Voltage drop due to aging of the rectifying assembly decreases with service. After the first few months of use the rectifier should operate for long periods without the necessity for readjustment. If at any time it becomes necessary to use the maximum regulation tap to obtain the proper output current, the rectifier should be withdrawn from service and repaired.

* * *

REVISIONS

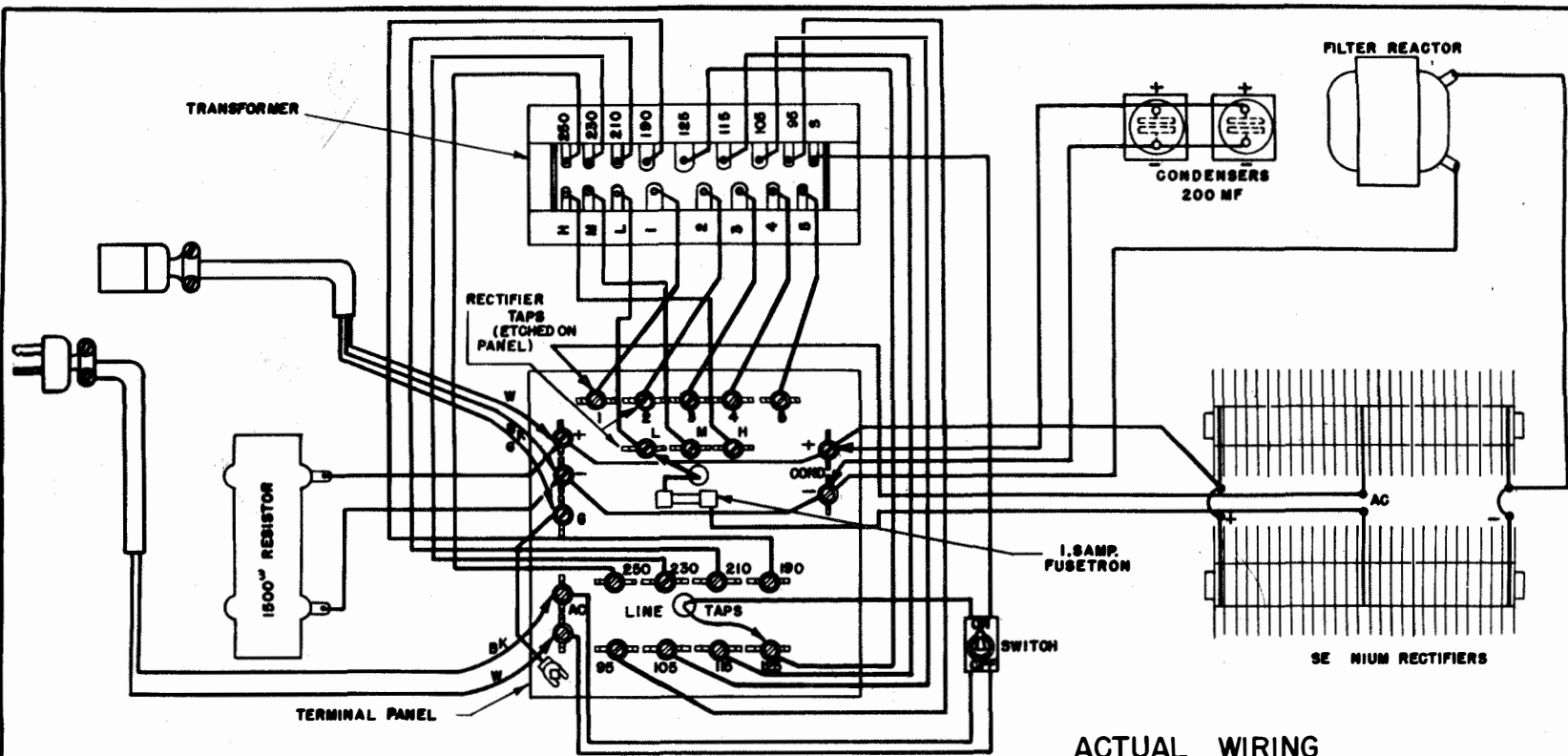

ACTUAL WIRING

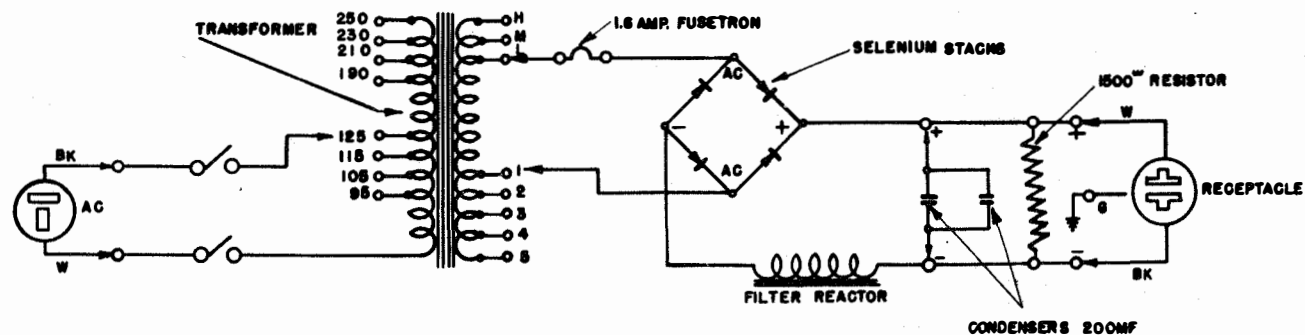

SCHEMATIC WIRING

TELETYPE CORPORATION

WD-2192-A

WIRING DIAGRAM
FOR
RECTIFIER
REC 32

DRAWN
TRACED C M C
CHECKED BK
ENG'D BK
APPROVED *RF*

