

INSTRUCTIONS FOR INSTALLING THE TELETYPE  
MODEL 28 PAGE PRINTER SET

1. GENERAL

a. Essentially, a complete Model 28 Page Printer Set consists of:

- (1) Cabinet
- (2) Electrical Service Unit
- (3) Motor Unit
- (4) Set of Gears
- (5) Base or Keyboard
- (6) Page Typing Unit

These are basic units some of which may be provided with various accessories for different service requirements. They are listed in the order of installation. For description and theory of operation refer to the Model 28 Printer Description and Theory of Operation Bulletin.

2. INSTALLATION

NOTE: Unpack all components with care (for cabinet instructions see paragraph 2a (1)). Observe all caution labels and instructions. Muslin cloth bags and small loose parts should be kept with their associated apparatus until used in the installation.

a. Cabinet

(1) Installation

(a) Lay carton on its side, then cut open the bottom sealed edges. Hold carton flaps back and stand the carton upright (two men should handle this phase). Grasp carton and pull up and off the cabinet. Remove top and side packing frame. Move cabinet carefully off base and remove paper cover.

(b) Four tapped bushings are provided for securing the cabinet directly to the mounting surface. In selecting the mounting bolts to be used, be certain each bolt will engage all the threads in the tapped bushing. The proper bolt thread and spacing between bolts are shown in Figure 1 (floor model) and Figure 2 (table model).

(c) Four adjustable feet permit a maximum variation of one inch in height at each corner for the purpose of leveling the cabinet. Apply a 3/4 inch open end wrench to the heads of the feet to make the adjustments.

(d) Instructions for installing separately packed accessories,

such as shock mounts, etc. are included with the sets of parts.

(2) Electrical Connections

(a) Two holes, containing filler plugs, are provided in the rear corners of the floor of the printer compartment. Two additional holes, containing knockouts, are provided in the rear corners of the floor of the lower compartment. Electrical connections are made by opening these holes and feeding cords up from the bottom through the holes. Telegraph and power circuits may enter through either the left or right hole. Wires or cords (used in the table cabinet) which are threaded through these holes should be taped. Thus, the taped plug will act as a "hole stopper" for noise reduction as well as strain relief, when desired.

(b) Cord connectors are provided for securing the cords at the input point to the floor mounted cabinet, thus providing for strain relief. Friction or electrical tape may be wound around the wires, at the clamping point, if additional thickness is required. The connectors are supplied in a muslin bag which is tied inside the lower compartment.

(c) A horizontal wiring channel with two terminal blocks extends across the upper rear position of the printer compartment of the cabinet. These terminals are protected with insulating covers which are secured to posts in the channel by means of screws and lock washers. Remove the covers to expose the terminals so that set connections may be made.

(d) Make power and telegraph circuit connections to the cabinet and attach the various units comprising the Printer Set, in accordance with the appropriate printer set specifications and wiring diagrams. An actual wiring diagram of each unit is packed with the unit, while a schematic wiring diagram of the complete printer set is packed with the Electrical Service Unit.

(e) A cabinet ground stud is provided above the right end terminal strip. A wire connected to the common station ground should be attached to the ground studs in each cabinet at the time of installation.

(3) Use of Lower Compartment Door as Maintenance Tray in floor Model Consoles, after the Electrical Service Unit is installed (see paragraph 2b for Electrical Service Unit Installation).

(a) Loosen the two fasteners holding the top of the door in place, holding on to a door handle so it does not fall open. Remove the rod at the bottom of the door, which acts as a hinge, by compressing the spring on the rod, removing the other end from its slot, then withdrawing the rod from its other slot. Remove the door.

(b) In initial use, remove the two 151726 rubber bumpers, which are found in a cloth bag tied to the hinge rod, from the bag and push them onto the front two upright projections of the electrical service unit. The bag may then be discarded and the bumpers left in place.

(c) With the printer out of the cabinet, insert the door, with inside up and hinge end to the rear, under the terminal block mounting strip.

Lower the front or top of the door until the handles on the door rest on the cross bar assembly. The rear of the door will then rest on the rubber bumpers mounted on the Electrical Service Unit. (See Figure 3). The tray is now ready for use.

(d) Reverse the procedure to put the door back in the lower section of the cabinet.

b. Electrical Service Unit

(1) The Keyboard and Typing Unit, if already installed, must be removed from the Cabinet to facilitate installation of the Electrical Service Unit.

\*(2) With the cabinet dome raised, place the Electrical Service Unit in the rear of the Cabinet, with the legs extending upward and serial number plate facing the front of the Cabinet, and secure it in position with the two 151437 studs furnished with the unit. The fuse holder and convenience receptacle should be on the right side of the unit when installed in the Cabinet.

\*(3) Route the cabinet terminal block cables (emanating from either side of the unit) behind their respective 74546 cable guides and connect them to the lower row of terminals on the cabinet terminal blocks. Make connections as shown on the applicable wiring diagram allowing sufficient slack near terminals.

(4) Route the Typing Unit and Keyboard cables behind their respective 151956 cable guides, forward through their 151955 cable guides mounted on the 151522 side cradle rails and back to the connectors on their respective units.

(5) Connect the cabinet lighting, margin indicator, signal bell, signal line, and power line cables to the terminals as shown on the wiring diagram, if necessary.

(6) Make the necessary strap connections at the cabinet terminal blocks as shown in the wiring diagram of the Electrical Service Unit.

(7) Remove the rear crossbar of the cradle assembly on the cabinet by removing its two mounting screws, lock washers, and flat washers.

(8) Manual Switch

(a) Untie the 151541 power switch shaft from the hinge bar and bracket. Remove the 151556 knob by loosening the two set screws.

(b) Place the bracket end of the 151541 power switch shaft on the electrical service unit power switch then locate the 151541 shaft in the hole on the right side of the electrical service unit container. Be certain that the front end of the power switch shaft is located in the hole on the right front of the cabinet.

(c) Place the 151559 power switch shaft spring on the power switch shaft then hook it to the hole in the side cradle rail of the cradle assembly.

(d) Replace the 151556 power switch knob on the shaft which protrudes through the cabinet, and keep the narrow portion of the knob to the right. Tighten the set screws.

(9) Servicing - The Electrical Service Unit may be turned upside down for servicing without removing any of the cabinet terminal block wiring and without removing the Keyboard or Typing Unit from the Cabinet. Tilt the Keyboard forward so the Base is latched, then remove the two 151437 studs holding the unit in place. The unit may be inverted by tilting it forward.

#### c. Motor Unit

\*(1) Remove the gear guard tied to the Keyboard or Base, then remove four of the 1/4-32 hex. head screws with captive lock washers from the muslin bag tied to the gear guard. Secure the Motor Unit to the Keyboard or Base with the four screws and lock washers just removed (connecting the ground strap on IMU4 to the right rear motor mounting screw) so that the formed ears of the guard are positioned over the rear surface of the keyboard or Receiving Only Base.

(2) Remove the insulator cover from the terminal block on the Keyboard or Base, just to the left of the motor. Connect the motor leads to terminals 1 and 2 of this terminal block for units not equipped with paper feed out switch.

#### d. Set of Gears

(1) Remove the motor gear and the intermediate driven gear from the small cardboard box stamped "151060" (furnished with the Printer Set), "151075", or "151100". Remove the screw and lock washer in the left end of the motor shaft. Place the motor gear on the motor shaft with the geared end toward the motor. Secure the gear with the screw and lock washer just removed. Remove the two screws and lock washers from the hub on the right end of the intermediate gear shaft. Mount the intermediate driven gear on the shaft with the flat side of the gear to the right. Secure the gear with the two screws and lock washers removed and make certain that the motor gear, intermediate driven gear, and page typing unit gear are properly meshed.

#### e. Keyboard or Base

(1) Remove the cross bar from the front of the Cabinet by loosening the two knurled thumb screws that secure it.

(2) Remove the two studs from the rear cross bar previously removed from the cradle assembly. With the centerline of the tapped holes to the rear of the centerline of the elongated holes in the rear cross bar, secure the Keyboard or Base with Motor Unit to the rear cross bar by means of the two studs just removed.

(3) Remove the two studs from the front cross bar hinge. Place the Keyboard or Base on the cradle assembly in the Cabinet. Loosen the two front cross bar mounting screws and position the bar in its elongated mounting holes so that the holes in the Base and the tapped holes in the hinge are in alignment. Secure the Base to the front cross bar hinge by means of the two studs just removed.

(4) Replace the front cabinet cross bar in its mounting slots. Tighten the two knurled thumb screws.

(5) To seal the rubber sealing plate around the Keyboard or Base Cabinet, push the Keyboard or Receiving Only Base toward the rear of the Cabinet as far as possible. Hold it in this position and tighten the two front cross bar mounting screws.

(6) Secure the rear cross bar to the cradle assembly by means of the two screws, lock washers, and flat washers previously removed.

(7) Insert the plug on the cable from the right end of the Electrical Service Unit into the receptacle on the right side of the Typing Unit until it is latched in position.

(8) Insert the plug on the cable from the left end of the Electrical Service Unit into the receptacle on the left rear corner of the Keyboard or Base until it is latched in position.

#### f. Typing Unit

(1) Install the type box on the Typing Unit if not previously installed.

(2) Remove the four remaining 1/4-32 hex. head screws with captive lock washers from the muslin bag and secure the Page Typing Unit to the Base.

\*(3) For list of adjustments see paragraph 3 of this specification.

#### g. Mechanical Checking of Equipment

(1) A visual check of all fuses, plugs, screw terminal connections, and lamps for loosening or breakage should be made before putting the equipment into operation.

(2) Make certain that the power knob is downward to its "OFF" position before closing the main power to the equipment.

#### (3) Lighting Facilities

(a) For Cabinets up to and including LAC202\*\*, two light switches are to be checked as follows:

1. The light switch (ON, OFF, MAIN ON) located on the Electrical Service Unit, should be in the "ON" position.

2. The copy light switch located to the left of the window in the cabinet dome, should be in the "ON" position.

(b) For Cabinets LAC203\*\* and up, a universal lighting system, comprising the copy light and margin indicator sets of parts, is used. The switch is located to the left of the window in the cabinet dome and should be in the "NORMAL ON" position.

(4) Refer to Model 28 Printer Adjustment Bulletin for instructions for installing paper and ribbon.

#### h. Operating Tests

(1) Type several lines of a sentence such as "The quick brown fox etc." and check for accuracy.

(2) The local line feed key (LOC LF), when depressed, should cause paper to be fed out of the machine at approximately three times faster than when the line feed key is repeatedly operated.

(3) The keyboard lock key (KBD LOCK), when depressed should prevent operation of any other key except the local line feed, keyboard unlock, and local carriage return keys. It should remain depressed until released by the keyboard unlock key.

(4) The keyboard unlock key (KBD UNLK), when depressed, should unlock the keyboard. The break key, when depressed, should hold the transmitting line open. If the duration of the open-line interval is greater than two character cycles, the keyboard lock should operate.

(5) The repeat key (REPT), when depressed together with any other key lever except the local keys, should cause repeated transmission of the signal.

(6) The local carriage return key (LOC CR), when depressed, should cause the carriage to return.

(7) With the type box in figures position, the bell should ring clearly on single or repeated operations of the Bell key.

(8) Determine that the operation of the FIGS key conditions the machine for the typing of upper case characters, and that the operation of the LTRS key conditions it for the typing of lower case characters.

X (9) Determine that operation of the space bar conditions the machine for the typing of lower case characters where this feature is desired. If this feature is not desired, disable the space bar by adjusting the unshift on-space function-pawl disabling screw as prescribed in the adjustment bulletin.

### 3. ADJUSTMENTS

NOTE: During shipment of the equipment and/or long periods of storage, it is possible that lubricant from adjacent mechanisms may have spread to the selector magnet pole faces and armature. Therefore, it is suggested that to

obtain the most efficient operation of the selecting mechanism, insert a piece of bond paper between the armature and pole faces to soak up any lubricant which may have accumulated. When removing the bond paper make sure no lint or bits of torn paper remain between the pole faces and armature.

The following adjustments should be made in the field during initial installation of the printer set, prior to placing the Keyboard or Base and Typing Unit into the Cabinet. They should also be checked on substitution of either a Keyboard or Base or Typing Unit at a later date. Refer to Model 28 Printer Adjustment literature:

- a. Mounting Typing Unit on Base
- b. Intermediate Gear Bracket
- c. Motor Speed (Governed Motors)
- d. Time Delay Disabling Device
- e. Electrical Service Unit
- f. Front Guide Bracket (Sprocket Feed Units)
- g. Paper Guide (Sprocket Feed Units)
- \*h. Copy Window (Cabinet)(Sprocket Feed Units)
- \*i. Motor Synchronous

NOTE: When necessary to reset the thermal cutout switch, wait at least five minutes before resetting.

\* \* \*

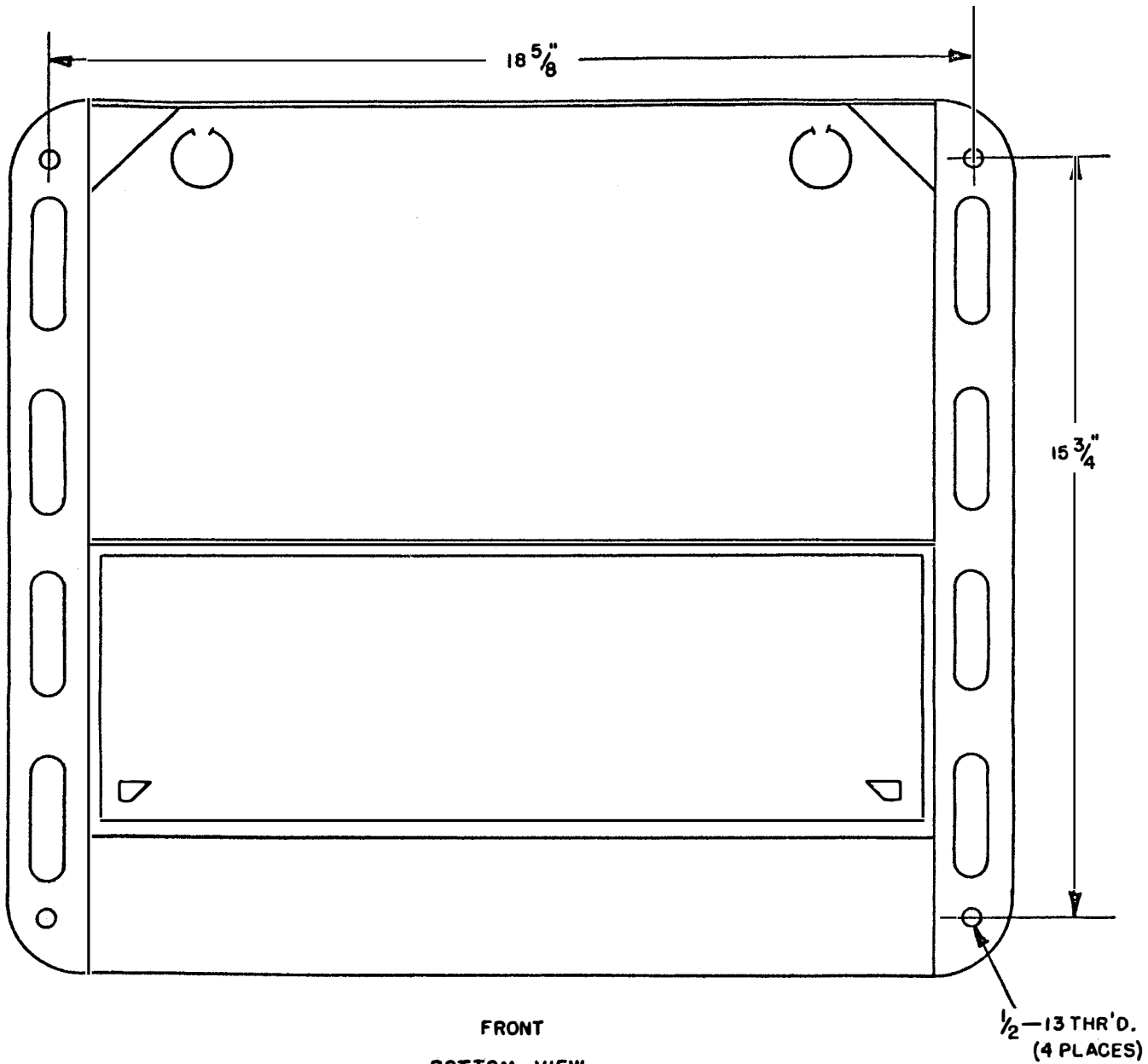

FRONT  
BOTTOM VIEW

FIGURE I



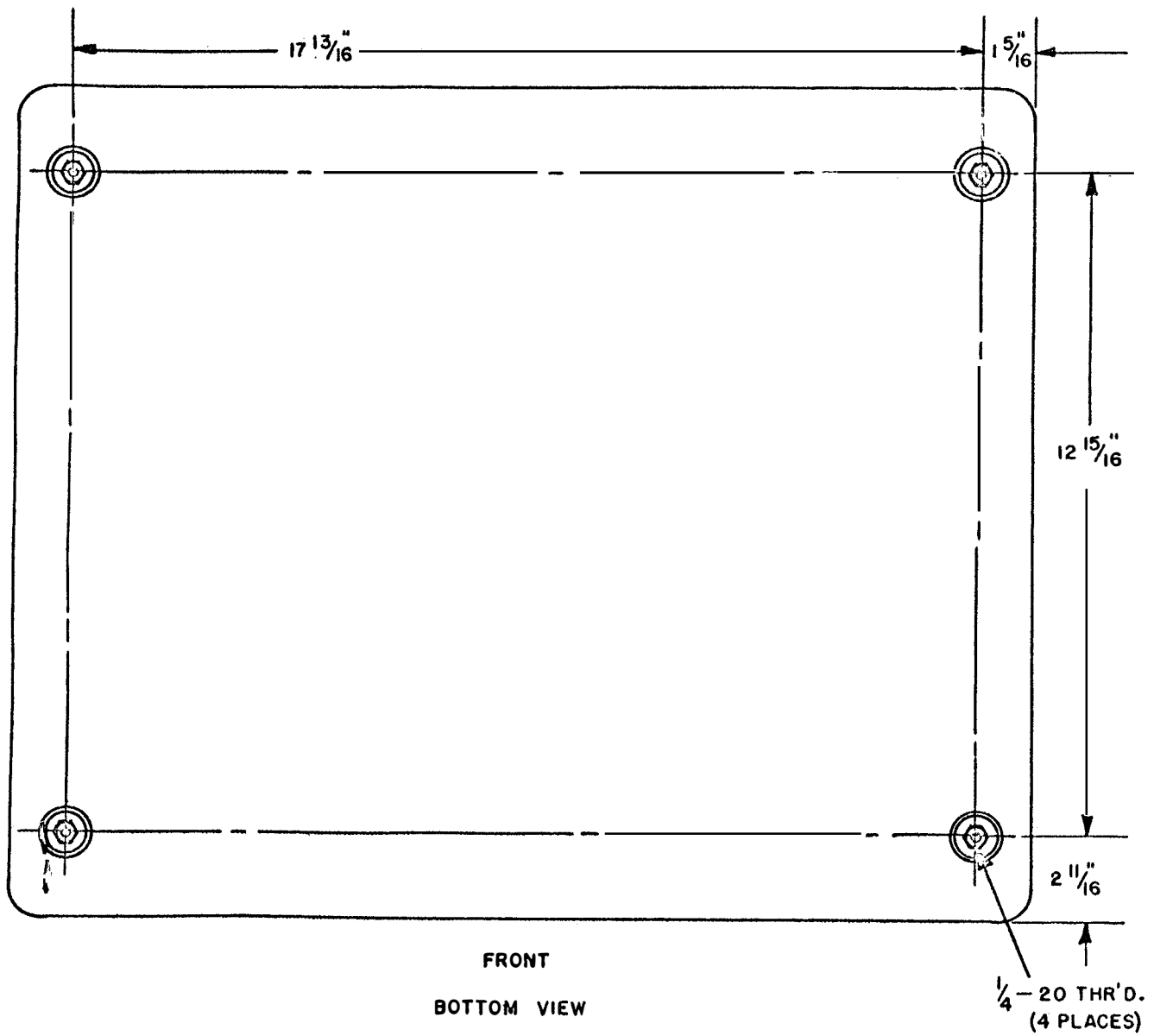

FRONT  
 BOTTOM VIEW  
 FIGURE 2

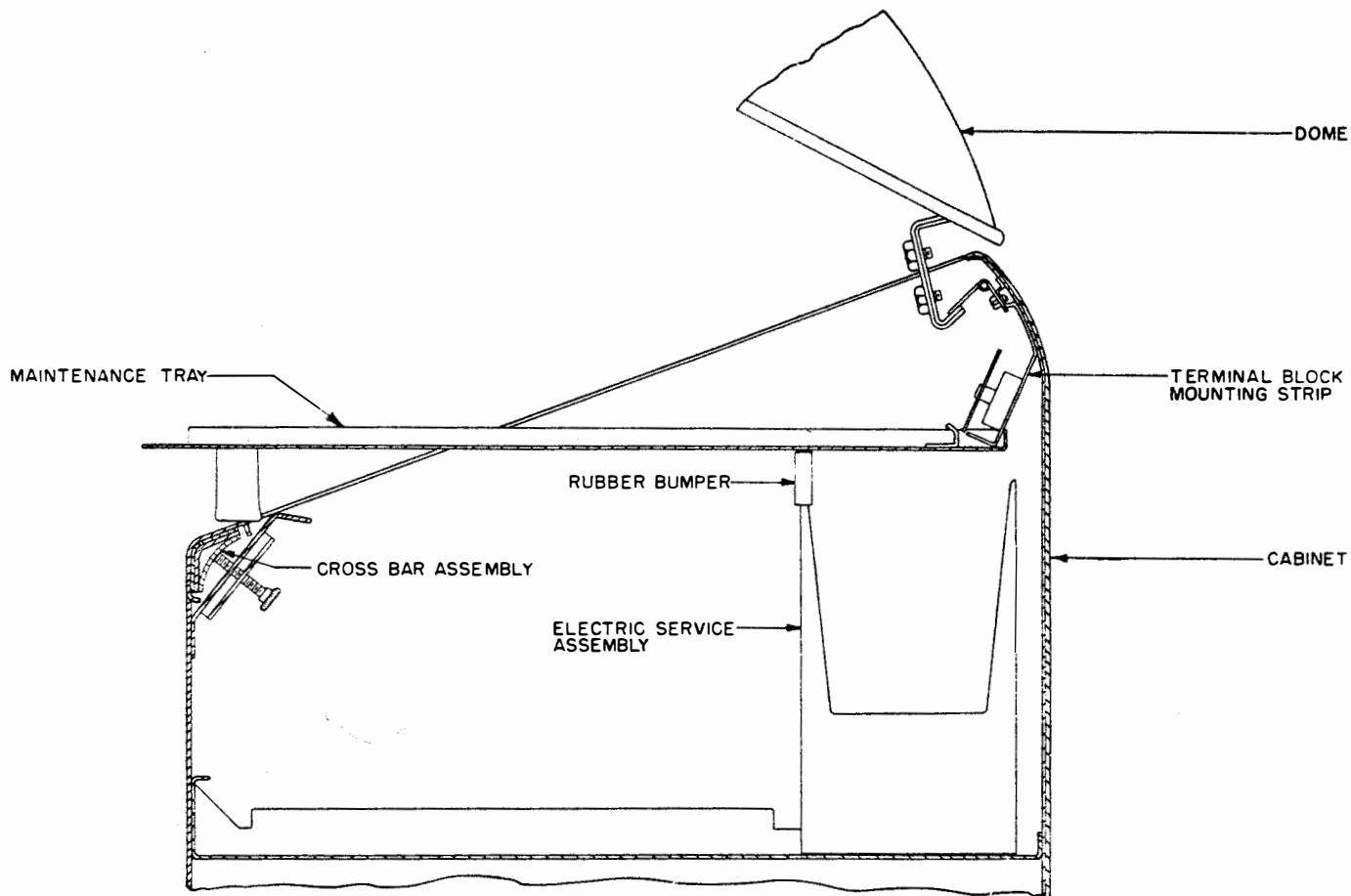

FIGURE 3