

ADDENDUM TO ADD THE 147984 MODIFICATION  
KIT TO CONVERT AN XD WITH FRICTION CLUTCH TO  
AN ALL METAL CLUTCH

- a. The 147984 kit is the same as the kits covered on Page 1, Paragraph 1. a. of the Teletype Specification 5787S except that the gears are omitted.
- b. The contents of kit 147984 are to be found on the check list that comes with each kit.
- c. The installation procedure for kit 147984 starts on Page 7, Paragraph 2. a.
- d. For standard adjustments and lubrication procedures see Teletype Bulletin 141B.
- e. In the body of the specification change part #104702 to 151687, 74613 to 152893, and 1179 to 150040.

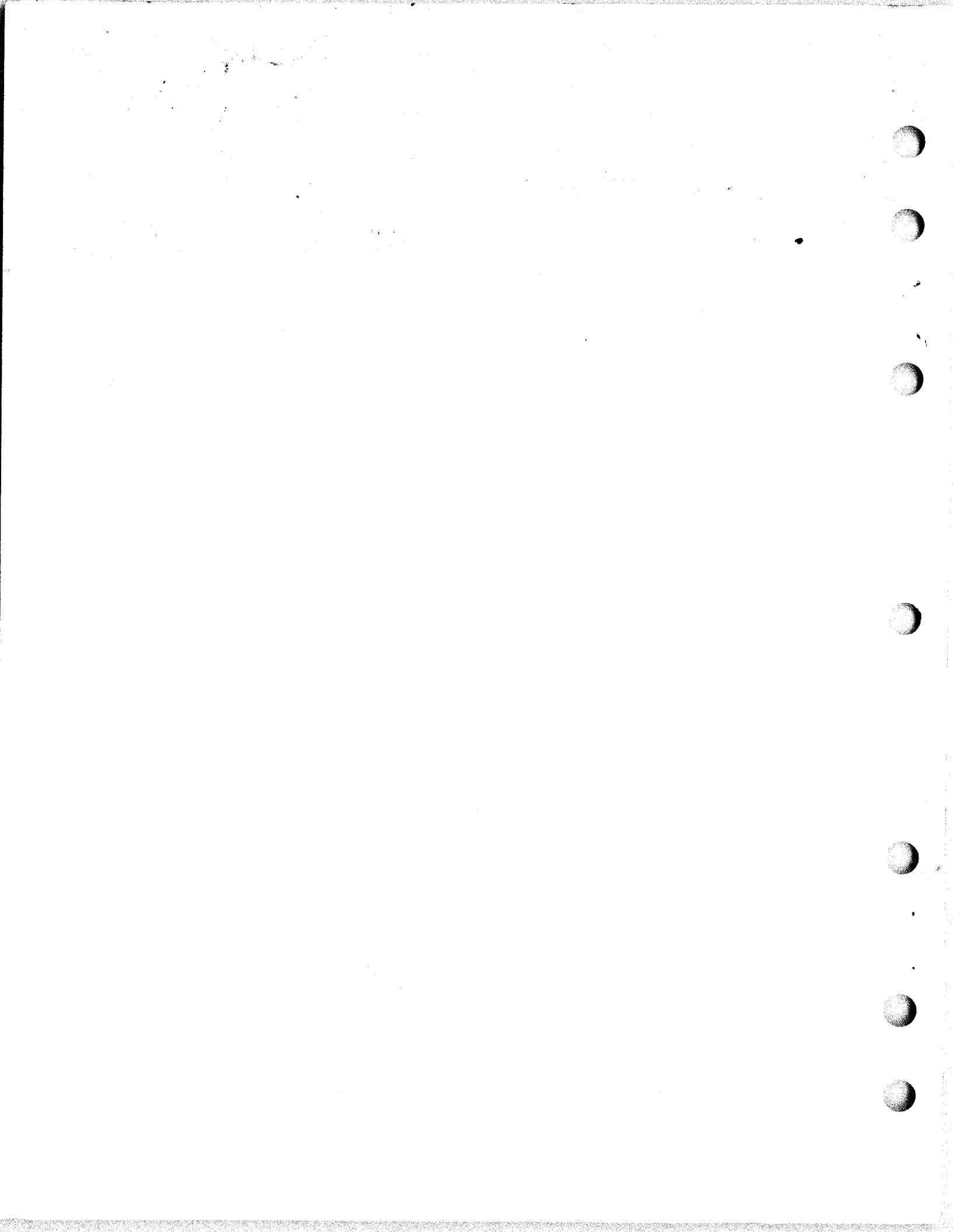

**\*INSTRUCTIONS FOR INSTALLING THE 113765 THROUGH 113775, 136025 THROUGH 136027, 136037 MODIFICATION KITS TO PROVIDE AN ALL STEEL INTERNAL EXPANSION CLUTCH, THE 136154 MODIFICATION KIT TO PROVIDE POSITIVE STOP ACTION WITH THE ALL METAL CLUTCH, AND THE 136147 AND 142546 MODIFICATION KITS PROVIDING CHARACTER-BY-CHARACTER BASIS OPERATION ON A MODEL 14 OR MODEL 20 TRANSMITTER DISTRIBUTOR**

1. General

a. The 113765 through 113775 and 136025 through 136027 Modification Kit when installed on a Model 14 or Model 20 Transmitter Distributor provides improved clutch stability and improved signal quality. Each modification kit includes a driven gear and all metal clutch which replace the driven gear and friction clutch. This clutch eliminates the use of friction disks and the need for frequent clutch lubrication and torque adjustments. The clutch assembly includes a bearing, mounting disk, shoe release lever and two movable shoes. This assembly is fastened to a main shaft by means of a screw. The clutch drum gear and bearing are fastened together and slipped onto the shaft. The 113772 and 113773 Modification Kits contain additional parts required for 100 W.P.M. operation. Operation of clutch is as follows:

With the start magnet de-energized, the stop lever engages the shoe release lever which permits the clutch shoes to withdraw from the clutch drum. The clutch drum, gear and gear bearing are then free to rotate with the motor pinion while the main shaft remains stationary. A latch lever drops in a notch in the stop disk and prevents oscillation of the disk. Energization of the start magnet causes the stop lever to release the clutch shoe release lever. The release lever causes the clutch shoes to engage the drum so that the entire clutch assembly rotates. Since the disk is attached to a disk bearing on the main shaft, the shaft rotates with the clutch.

b. The 136037 Modification Kit when installed on a Model 14 Transmitter Distributor XD228\*\* provides improved clutch stability and improved signal quality at 75 W.P.M. Operation of the clutch is as follows:

The motor pinion rotates the gear drum and bearing, and the main shaft is stationary until the start magnet is energized. The start magnet releases the stop lever and a spring pulls it away from engagement with the shoe release lever and the clutch shoes engage the drum. The main shaft is then rotated due to its engagement with the clutch drum and operates the sensing pins, distributor, and stop lever resetting cam. The start magnet is de-energized and a cam resets the stop lever into the path of the shoe release lever and the clutch shoes are disengaged from the drum. A latch lever which is spring activated falls into a notch in the clutch disk and provides a detent action to prevent oscillation of the clutch assembly.

TABLE 1  
COMPONENTS OF THE MODIFICATION KITS

Quantity	Part Number	Description	MODIFICATION KIT																		
			113765	113766	113767	113768	113769	113770	113771	113772	113773	113774	113775	136025	136026	136027	136037	136153	136154	136147	142546
1	<del>1179</del>	<del>Screw 6-40 x 5/8 Fil.</del>	X	X	X	X	X	<del>X</del>	X	X	X	X	X	X	X	X				X	X
2	2191	Lock Washer								X							X		X	X	
5	2191	Lock Washer	X	X	X	X	X	X	X	X	X	X	X	X	X	X			X	X	
2	3595	Nut 1/4-32 Hex	X	X	X	X	X	X	X	X	X	X	X	X	X	X			X	X	
1	3599	Nut 4-40 - 1	X	X	X	X	X	X	X	X	X	X	X	X	X						
1	3606	Nut 6-40 Hex														X			X	X	
2	3606	Nut 6-40 Hex	X	X	X	X	X	X	X	X	X	X	X	X	X						
1	3640	Lock Washer	X	X	X	X	X	X	X	X	X	X	X	X	X						
4	7002	Flat Washer	X	X	X	X	X	X	X	X	X	X	X	X	X	X			X	X	
1	8330	Flat Washer														X		X	X		
1	8670	Roller	X	X	X	X	X	X	X	X	X	X	X	X	X	X			X	X	
1	8671	Screw 6-40 Shoulder	X	X	X	X	X	X	X	X	X	X	X	X	X	X			X	X	
1	42661	Extension Spring									X						X		X	X	
2	42823	Flat Washer	X	X	X	X	X	X	X	X	X	X	X	X	X	X			X	X	
2	46183	Flat Washer	X	X	X	X	X	X	X	X	X	X	X	X	X	X			X	X	
1	49420	Spring														X		X	X		
2	74613	Screw 4-40 x 1/4 Hex	X	X	X	X	X	<del>X</del>	X	X	X	X	X	X	X	X			X	X	
1	74691	Resistor (1600 Ohms)																X			
2	75646	Screw #0 x 3/16 Drive	X	X	X	X	X	X	X	X	X	X	X	X	X	X			X	X	
1	76058	Spring Post														X		X	X		
1	76099	Flat Washer									X						X		X	X	
1	77025	Pinion - 10T									X										
2	80342	Screw 6-40 x 23/64 Hex									X						X		X	X	
2	81814	Brush Spring Stiffener									X						X		X	X	
2	82440	Screw 6-40 x 7/16 Hex														X			X	X	

3	82440	Screw 6-40 x 7/16 Hex		X	X	X	X	<del>X</del>	X	X	X	X	X	X	X				
1	82725	Extension Spring								X							X	X	X
1	87401	Spring														X		X	X
1	88752	Felt Oiler	X	X	X	X	X	X	X	X	X	X	X	X	X	X		X	X
1	90517	Extension Spring	X	X	X	X	X	X	X	X	X	X	X	X	X				
1	90573	Extension Spring	X	X	X	X	X	X	X	X	X	X	X	X	X				
1	98142	Spacer	X	X	X	X	X	X	X	X	X	X	X	X	X				
1	91904	Flat Washer	X	X	X	X	X	X	X	X	X	X	X	X	X				
1	77042	Disk Assembly																X	X
1	85483	Plate															X	X	X
1	87401	Spring															X		
1	96204BK	Strap															X		
1	104657	Gear Guard															X	X	X
1	104669	Magnet Assembly															X	X	X
1	101439	Feed Lever Stop									X						X	X	X
5	101715	Spring Assembly									X						X	X	X
1	104702	Screw 4-40 x 7/16 Fil	X	X	X	X	X	X	X	X	X	X	X	X	X				
4	110743	Lock Washer	X	X	X	X	X	X	X	X	X	X	X	X	X	X		X	X
1	110883	Pinion - 12T															X		
1	110885	Arm									X						X	X	X
1	110886	Spring Anchor									X						X	X	X
2	110887	Pilot Screw 1/4 - 32									X						X	X	X
1	115529	Screw 6-40 x 11/16 Fil									X								
1	125011	Flat Washer	X	X	X	X	X	X	X	X	X	X	X	X	X				
1	129289	Disk	X	X	X	X	X	X	X	X	X	X	X	X	X	X		X	X
1	129290	Disk	X	X	X	X	X	X	X	X	X	X	X	X	X	X		X	X
1	129292	Shoe Lever	X	X	X	X	X	X	X	X	X	X	X	X	X	X		X	X
1	131629	Nut (Special															X		
1	135030	Shaft	X	X	X	X	X	X	X	X	X	X	X	X	X	X		X	X
1	135031	Bearing	X	X	X	X	X	X	X	X	X	X	X	X	X	X		X	X
2	135032	Bearing Cover	X	X	X	X	X	X	X	X	X	X	X	X	X	X		X	X
1	135033	Cam	X	X	X	X	X	X	X	X	X	X	X	X	X	X		X	X
1	135034	Clutch Drum	X	X	X	X	X	X	X	X	X	X	X	X	X	X		X	X
1	135035	Helical Gear 36 T															X		

1	135036	Helical Gear - 44T	X																
1	135037	Bearing	X	X	X	X	X	X	X	X	X	X	X	X	X	X		X	X
4	135038	Screw 6-40 x 9/16 Hex	X	X	X	X	X	X	X	X	X	X	X	X	X	X		X	X
2	135039	Pilot Screw 1/4-32	X	X	X	X	X	X	X	X	X	X	X	X	X	X		X	X
1	135040	Spring Bracket	X	X	X	X	X	X	X	X	X	X	X	X	X				
1	135041	Backstop Bracket	X	X	X	X	X	X	X	X	X	X	X	X	X				
1	135042	Brush Holder Arm								X						X	X	X	X
1	135043	Stop Lever	X	X	X	X	X	X	X	X	X	X	X	X	X				
1	135044	Latch Lever	X	X	X	X	X	X	X	X	X	X	X	X	X				
1	135061	Helical Gear - 35T								X									
1	135062	Helical Gear - 34T									X								
1	135064	Helical Gear - 32T							X										
1	135065	Helical Gear - 50T				X													
1	135066	Helical Gear - 53T					X												
1	135067	Helical Gear - 53T			X														
1	135068	Helical Gear - 40T		X															
1	135069	Helical Gear - 53T										X							
1	135070	Bracket								X							X	X	X
2	135072	Lock Washer								X							X	X	X
*1	136153	Modification Kit							X										
1	136525	Helical Gear - 47T						X											
1	136552	Helical Gear - 14T																	
1	136579	Helical Gear - 10T																	
1	136580	Helical Gear - 42T																	
1	136582	Helical Gear - 13T																	
1	136583	Helical Gear - 60T																	
1	136585	Helical Gear - 49T													X				
1	136949	Reset Cam														X	X	X	X
1	136950	Stop Lever														X	X	X	X
1	136951	Latch Lever														X	X	X	X
1	136952	Helical Gear - 48T														X			
1	150029	Oil Wick	X	X	X	X	X	X	X	X	X	X	X	X	X			X	X
1	150043	Secondary Shoe	X	X	X	X	X	X	X	X	X	X	X	X	X			X	X
1	150044	Primary Shoe	X	X	X	X	X	X	X	X	X	X	X	X	X			X	X

1	150241	Extension Spring	X	X	X	X	X	X	X	X	X	X	X	X	X	X	X	X	X
1	151629	Nut 6-40 Special																X	X
1	151688	Screw 4-40 x 5/8 Fil	X	X	X	X	X	X	X	X	X	X	X	X	X	X			
1	151728	Extension Spring	X	X	X	X	X	X	X	X	X	X	X	X	X	X			X
1	155098	Patent Plate	X	X	X	X	X	X	X	X	X	X	X	X	X	X			X
2	151737	Screw 4-40 x 3/16 Hex.	X	X	X	X	X	X	X	X	X	X	X	X	X	X			X
1	142547	Helical Gear - 10T																	X
1	142548	Helical Gear - 28T																	X
1	142662	Helical Gear - 11T																	X
1	142663	Helical Gear - 36T																	X

c. The 136147 Modification Kit when installed on a Model 14 Transmitter Distributor equipped with a 2102 RPM governed motor or the 142546 Modification Kit when installed on a Model 14 Transmitter Distributor equipped with a 1800 RPM, 60 cycle synchronous motor provides operation at 75 baud on a stepped, character-by-character basis. When a 115 V DC, .060 ampere pulse is supplied to the start magnet at the rate of 10 times per second, the signal from the transmitter distributor will be similar to that of a 100 WPM transmitter distributor. The modification kits contain an all metal clutch, a 7.0 code distributor disk, and a special start magnet assembly. Operation is as follows:

(1) The motor pinion rotates the main shaft gear, clutch drum and bearing assembly while the main shaft remains stationary. When the start magnet is energized, the armature extension releases the stop lever and a spring pulls it away from engagement with the clutch shoe release lever allowing the clutch shoes to engage the clutch drum. The main shaft then rotates, due to the clutch shoes engaging the rotating clutch drum, and operates the sensing pins and distributor. While the main shaft is making one complete revolution a cam on the main shaft resets the stop lever into the path of the clutch shoe release lever, stopping the main shaft until the start magnet is re-energized.

(2) The modified transmitter will run at a free shaft speed of 642.85 RPM and, being equipped with a 7.0 code distributor disk, also runs at 75 baud. The length of each pulse, except that of the stop pulse due to the unit stopping each revolution, is .0135 second. If the start magnet is pulsed 10 times per second, then the stop pulse will be .019 second and the signal will be similar to that of a 100 WPM unit.

d. Numbers of the modification kits and the associated motor and operating speed data are shown in the table, below:

Mod. Kit Number	Transmission Speed OPM	Motor Speed RPM	New Gear No.	Old Clutch Gear No.	Pinion Mate
113765	368	1800	135036	80165	80166
113766	368	2102	135068	77036	77034
113767	368	1500	135067	91132	91131
113768	396	1800	135065	116766	116767
113769	396	2102	135066	123712	123711
113770	460	1800	136525	91284	91285
113771	460	2102	135064	91282	91283
113772	600	1800	135035	110884	110883
113773	600	2102	135061	77026	77025
113774	317	1800	135062	87372	87371
113775	317	2102	135069	123718	123717
136025	428	1800	136580	-	136579
136026	390	1800	136583	-	136582
136027	428	2102	136585	121087	121086
136037	525	1800	136952	-	136552
*136147	643	1800	142548	-	142662
*142546	643	2102	142663	-	142547



\*e. The 136154 Modification Kit provides positive stop action for the Model 14 Transmitter Distributor equipped with an all metal clutch. This modification kit is used in association with a 28 Type Printer equipped with a Horizontal Tabulator Transmitter Distributor control feature to eliminate the need for two "fill in" characters and restoring normal operation procedure.

\*f. For part numbers referred to and for parts ordering information see Teletype Model 14 Transmitter Distributor Parts Bulletin and associated correction sheets. Also refer to Correction Sheet 844EE which is included with the modification kit for parts ordering information.

\*g. A 155098 Patent Plate is included with each modification kit and must be affixed to the converted unit; except kits 136153 and 136154.

## \*2. INSTALLATION

a. 113765 through 113775, 136025 through 136027 Modification Kits.

(1) Remove and retain the distributor cover, the transmitter snap panel and the base plate. It may also be necessary to remove the transmitter cover and its supporting bracket when installing 100 speed or chadless tape parts.

(2) Remove and discard the 6990 Stop Arm Pivot Screws and 125218 Nuts.

\* (3) Remove and retain 74059 Screw and 2191 Lock Washer from 77001 Stop Arm and 84115 Armature. Discard the 77001 Stop Arm.

(4) Remove and retain the 8539 Screw, 2191 Lock Washer, 7002 Washer and brush holder assembly.

(5) Remove and retain the brush arm assembly and mounting screw.

(6) Remove and retain two 74838 Main Shaft Bearing Caps and associated 6811 and 8539 Screws and 2191 Lock Washers.

(7) Remove and retain the main shaft assembly.

(8) Remove and discard the 125696 Spring Post and its spring.

(9) Mount the 135040 Spring Bracket to the 77082 Bracket using the <sup>151687</sup>~~125696~~ 2 Screw, 3640 Lock Washer, 125011 Washer and 98142 Spacer in place of the 125696 Post removed in Paragraph (8).

## NOTE

Make certain that the spring bracket is mounted as nearly vertical as possible with the spring holes, toward the transmitter of the unit, the projection on the bracket extending to the rear and the spacer between the spring bracket and the 77082 Bracket. To facilitate the

installation of the springs as called for in Paragraph 2.a.(26), hook one end of the 90517 Stop Lever Spring in the upper hole and one end of the 90573 Latch Lever Spring in the lower hole of the spring bracket.

(10) Attach the 129289 Disk (projection upward) to the 135031 Bearing using the two ~~2413~~ Screws, 46183 Washers, 110743 Lock Washers.

151893

(11) Assemble the 129290 Disk (projection upward) on the 129289 Disk using two 151737 Screws inserted through the elongated slots and the 110743 Lock Washers and 42823 Washers.

(12) Hook the 151728 Spring to the 129292 Shoe Release Lever and place the lever (projection upward) in the lower groove of the 135031 Bearing with the outer projection of the lever to the left of the projection on the 129289 Disk when the assembly is rotated so as to bring the projection direction in front of the observer. Connect spring to post.

(13) Place the 150029 Oil Wick over the adjusting disk projection with the tongue between ears of the shoe release lever.

(14) Hook the 150241 Spring to the 150043 Shoe and slide the shoe into the top bearing groove with the adjusting disk projection in the slot.

(15) Place the 150044 Shoe in the top bearing groove opposite the 150043 Shoe. Connect the 150241 Spring to the 150044 Shoe. Check the Clutch Shoe Lever Spring Tension.

(16) Mount the 135031 Bearing on the 135030 Shaft using the ~~122~~ <sup>150040</sup> Screw, 3606 Lock Nut and 2191 Lock Washer; keep the shoes toward the upper portion of the shaft.

(17) Secure the new gear with the 135037 Bearing to the 135034 Clutch Drum with the flange of the bearing inside the hollow of the gear and the shorter portion of the bearing protruding through the gear and the clutch drum, using four 135038 Screws, 2191 Lock Washers and 7002 Washers.

(18) Place the 88752 Felt Oiler over and into the bearing slot.

(19) Hold the shoe release lever against the clutch stop disk projection and slide the drum, gear and bearing over the clutch shoes.

#### NOTE

The assembly of the clutch can be facilitated by loosening the two 151737 Adjusting Disk Clamp Screws (Paragraph 2.a.(11) and retightening them when making the clutch shoe lever adjustment.

(20) Remove the following parts from the main shaft assembly (previously removed in Paragraph 2.a.(7) and remount them on the new main shaft assembly in the same relative positions:

MAIN SHAFT  
ASSEMBLY

MAIN SHAFT  
ASSY -9-  
(57875)

1	72579	Washer	2	4814	Lock Washer
1	77058	Cam Hub	2	3288	Washer
2	2201	Nut	2	72644	Ball Bearing

Replace the 77020 Bearing Covers with the 135032 Bearing Covers.

- (21) Discard the remaining parts of the main shaft assembly.
- (22) Install the driving gear on the motor if one is furnished with the set of parts.
- (23) Install the new main shaft assembly in place of the old assembly using retained brackets and screws.
- (24) Attach the 84115 Armature (correct face to magnet) previously removed into the 135043 Stop Lever using 74059 Screw, 91904 Washer (furnished) and 2191 Lock Washer.

NOTE

For DC operation assemble with the notch (near top of armature) or for armatures stamped with a "C" toward the coil. For AC operation assemble with notch (near bottom of armature) or for armatures stamped with a "C" away from coil.

(25) Assemble the 135043 Stop Lever (with parts assembled in paragraph 2. a. (24) above) and the 135044 Latch Lever in the same position where the 77001 Stop Arm has been mounted. Also mount the 135041 Backstop Bracket above the top mounting lug of the main shaft bracket using the 135039 Pilot Screws and 3595 Lock Nuts. The tapped hole in bracket should be downward and toward armature. Install the 151688 Screw and 3599 Lock Nut to the 135044 Latch Lever.

(26) Hook the 90573 Spring between the latch lever and the spring bracket, and the 90517 Spring between the stop lever and the spring bracket.

(27) Place the 3606 Lock Nut on the <sup>153538</sup>~~82110~~ Backstop Screw, and thread it into the 135041 Backstop Bracket with the <sup>153538</sup>~~82110~~ Screw project through the 135041 Bracket toward the armature.

(28) Install the 135033 Cam in place of the 101441 Cam using two <sup>153538</sup>~~82110~~ Screws furnished and the washers and lock washers removed.

NOTE

If transmitter distributor is equipped with a 113814 Tape Lockout Solenoid, retain the 101441 Cam and assemble it to the 77058 Hub using two <sup>153538</sup>~~82110~~ Screws and retained washers and lock washers, placing enough washers or spacers between the cam and hub to bring the bottom surface of the cam approximately even with the end of the main shaft.

(29) Remove and discard the 112577 Roller, 1041 Shoulder Screw and 8330 Washer. Replace with the 8670 Roller, 8671 Shoulder Screw supplied and 2191 Lock Washer and

3606 Nut retained.

(30) For 113772 or 113773 Modification Kit (100 W.P.M. operation) the following additional instructions apply. (See Correction Sheet 844EE for location of parts):

(a) Remove the bracket assembly. Replace the 112623 Pilot Screws with the 110887 Pilot Screws and 135072 Lock Washers. Replace the bracket assembly.

(b) Install the 110885 Arm on the bail assembly in place of the present 77050 Arm. The arm can be removed by lifting it upward and rotating it toward the right after removing the mounting screws.

(c) Install the 110886 Spring Anchor on the operating lever between the lever and the adjusting screw lock nut. Position the spring anchor so that the springs are approximately in line.

(d) Install the 42661 Spring between the 110885 Arm and the 110886 Anchor.

(e) Install the 135070 Bracket under the base using two 80342 Screws, 2191 Lock Washers and one 76099 Washer.

(f) Install the 82725 Spring between the 135070 Bracket and the 110886 Spring Anchor.

(g) Replace the 86815 Brush Holder Arm with the 135042 Brush Holder Arm. Reuse the 80467 Screw, 8330 Washer, 77048 Bushing and the 77057 Brush Holder Assembly. Replace the brush holder arm assembly on the shaft.

(h) Install two 81814 Brush Stiffeners so that the end of each stiffener is within 1/16" from the carbon projection.

(i) On units which do not have provisions for chadless tape:

1. Unsolder the 81731 Contact Spring from the sensing contacts and replace it with the 101715 Spring Assembly.

2. Install the 101439 Feed Lever Upstop by removing the 1179 Inner Screw from the lever guide and placing the 101439 Feed Lever Stop, 2191 Lock Washer and 3649 Washer between the screw and the guide.

(31) Drill two .0635 dia. holes in the base casting and attach the 155098 Patent Plate with the 75646 Drive Screws under the Teletype name plate (centered) as shown in Figure 1.

b. 136037 Modification Kit

(1) Follow procedure in Paragraph 2.a.(1).

- (2) Follow procedure in Paragraph 2.a.(4).
- (3) Remove and retain the segment disk assembly by removing the three 81258 Mounting Screws of the 104528 Retaining Ring.
- (4) Follow procedure in Paragraph 2.a.(5).
- (5) Follow procedure in Paragraph 2.a.(7).
- (6) Install the 76058 Spring Post (4-40 thr) in the 77082 Main Shaft Bracket, just below the motor pinion.
- (7) Follow procedure in Paragraph 2.a.(29).
- (8) Follow procedure in Paragraph 2.a.(10) through (15).
- (9) Follow procedure in Paragraph 2.a.(17).
- (10) Hold the release lever against the clutch stop disk projection and slide the drum, gear and bearing assembly over the clutch shoes.
- (11) Follow procedure in Paragraph 2.a.(18).
- (12) Assemble the clutch and gear assembly on the 135030 Main Shaft with the gear side up (toward the brush end of the shaft). In sliding the assembly over the heavy section of the shaft, release the clutch shoes by holding the shoe release lever against the lug of the stop disk. The same procedure must be followed in lining up the lower bearing mounting hole of the clutch assembly with the tapped hole in the shaft, being careful that the clutch drum portion and the shoes are not being disengaged.

#### NOTE

If the clutch should become disengaged, the assembly should be removed from the shaft and the procedure previously described for the clutch assembly must be repeated.

Fasten the clutch assembly to the shaft by means of the 1179 Screw, 3606 Lock Nut and 2191 Lock Washer; keep the clutch shoes fully engaged with the drum. —

(13) Assemble the 136949 Reset Cam to the main shaft, just below the clutch assembly with the camming portion toward the clutch assembly; clamp the reset cam to the shaft, using the 115529 Clamp Screw, 8330 Washer and 151629 Nut.

(14) Remove and retain the following parts from the 105071 Main Shaft Assembly which was previously removed from the 77082 Main Shaft Bracket. Install these parts on the furnished 135030 Shaft in the same relative positions:

- |   |      |                                       |
|---|------|---------------------------------------|
| 1 | 6756 | Hub Mounting Screw (6-40 x 5/16 Hex.) |
| 2 | 2191 | Lock Washer                           |

1	105150	Hub
2	2201	Nut (5/16 x 32 Hex.)
2	4814	Lock Washer
2	72644	Ball Bearing
2	3288	Spacer
2	105069	Bearing Cover (discard and replace with 135032 cover furnished)
1	72579	Washer for Upper Bearing

(15) Follow procedure in Paragraph 2.a.(28).

(16) Replace the motor pinion with the furnished 136552 Pinion by removing the three 6745 Main Shaft Bracket Mounting Screws and 2669 Lock Washers and by moving the bracket sufficiently to replace the pinion. See that there is satisfactory clearance between the retained 104657 Gear Guard and the new pinion.

#### NOTE

If necessary bend the gear guard to obtain clearance.

(17) Remove and discard from the main shaft bracket the 104872 Clutch Lever Assembly by removing and discarding the two 6990 Pilot Screws and 125218 Nuts. Remove and discard the 74962 Lever Spring. Install the two furnished 135039 Pilot Screws and 3595 Lock Nuts in the ears of the main shaft bracket.

(18) Remount the main shaft bracket with the three 6745 Screws and 2669 Lock Washers.

(19) Install the new main shaft assembly in the main bracket with the two retained bearing caps and their mounting screws; being careful that the operating lever and its roller are located on the proper side of the shaft.

(20) Remount the segment disk assembly and the 104528 Retaining Ring.

(21) Assemble the 136950 Stop Lever and the 136951 Latch Lever to the main bracket by means of the two 135039 Pilot Screws and 3595 Lock Nuts.

(22) Hook the furnished 87401 Spring between the latch lever and the 76058 Spring Post and install the furnished 49420 Spring between the stop lever and the 104537 Spring Anchor which is mounted to the center of the magnet core cross piece.

(23) Follow procedure in Paragraph 2.a.(30)(g).

(24) Follow procedure in Paragraph 2.a.(31)

\*c. 136147 or 142546 Modification Kit

(1) Remove and retain the distributor cover.

- (2) Remove and retain the base plate by removing four 1264 Mounting Screws.
- (3) Remove the brush holder arm assembly from the main shaft. Retain all parts except the 86815 Brush Holder Arm.
- (4) Remove and discard the distributor disk assembly by removing and retaining three 8539 Screws and three 2191 Lock Washers. Unsolder wires.
- (5) Remove and discard the clutch stop lever assembly and spring by removing and discarding two 6990 Pilot Screws and two 125218 Lock Nuts.
- (6) Remove and discard the start magnet assembly and gear guard from the base by removing and retaining two 8539 Mounting Screws, two 2191 Lock Washers and two 7002 Flat Washers.
- (7) Follow procedure in Paragraphs 2.a.(6) and (7).
- (8) Replace the 125696 Spring Post on the main shaft bracket with the 76058 Spring Post.
- (9) Replace the two 112623 Pilot Screws with two 110887 Pilot Screws and two 135072 Washers.
- (10) Follow procedure in Paragraphs 2.a.(30)(b) through (f) inclusive, and (i).
- (11) Follow procedure in Paragraphs 2.a.(29), 2.a.(10) through (15) inclusive and (17).
- (12) Set the two screws of the clutch adjusting disk in the center of the elongated holes in the clutch stop disk. Slide the gear and clutch drum assembly over the clutch shoes of the clutch bearing assembly by holding the extension of the 129292 Shoe Release Lever against the lug of the Clutch Stop Disk 129289.
- (13) Follow procedure in Paragraph 2.a.(18).
- (14) Follow procedure in Paragraphs 2.b. (12), (13) and (14).
- (15) Replace motor pinion with the 142547 or 142662 Motor Pinion using the same mounting screws and lock washer.
- (16) Install the new main shaft assembly in the main shaft bracket with the two retained bearing caps and their mounting screws, being careful that the operating lever and its roller are located on the proper side of the cam.
- (17) Mount the 77042 Distributor Disk Assembly to the main shaft bracket using three retained 8539 Screws and 2191 Lock Washers. Solder all wires in the same relative position.

(18) Install the 135042 Brush Holder Arm on the main shaft using mounting screw and washer retained in Paragraph 2.c.(3).

(19) Install 77048 Insulating Bushing, 77063 Stop Post, 77057 Brush Holder, two 93009 Brushes, two 81814 Brush Spring Stiffeners, 77024 Clamp Plate, 80957 Screw, 8330 Flat Washer and 80467 Screw to the 135042 Brush Holder Arm (all parts were retained in Paragraph 2.c.(3) except the 81814 Brush Spring Stiffeners).

#### NOTE

Install two brush stiffeners so that the end of each stiffener is with 1/16" from carbon projection.

(20) Mount the 104657 Gear Guard, 85483 Spacer and the 104669 Start Magnet Assembly to the base with two retained 8539 Mounting Screws, 2191 Lock Washers and 7002 Flat Washers. See that there is satisfactory clearance between the gear guard and the pinion.

(21) Follow procedure in Paragraphs 2.b.(21), (22), 2.a.(31).

(22) Replace the base plate, with four 1264 Mounting Screws and distributor cover previously removed.

#### d. 136154 Modification Kit

(1) Remove and retain covers and bottom plate.

(2) Remove and retain the 135039 Pilot Screws (2), and 3595 Lock Nuts (2).

(3) Remove and discard 135041 Bracket, 135043 Stop Lever, 135044 Latch Lever, 90517 Spring, 90573 Spring, and associated parts.

(4) Remove and discard the clutch magnet assembly (including the 77021 Bracket) and gear guard retaining the 8539 Screw (2), 7002 Flat Washer (2), and 2191 Lock Washer.

(5) Remove and retain the brush holder arm assembly and associated parts.

(6) Remove and retain bearing caps.

(7) Remove and retain the three disk assembly mounting screws and main shaft assembly.

(8) Remove and replace the 135040 Spring Plate and associated parts with the 76058 Spring Post.

(9) Remove and retain the following parts from the bottom end of the main shaft:



77058	Cam hub with cam	72644	Ball Bearing
2201	Nut	3288	Flat Washer
4814	Lock Washer	135032	Bearing Cover

(10) Assemble the 136949 Reset Cam to the main shaft just below the clutch bearing with the camming portion upward towards the 135031 Clutch Bearing. Clamp the reset cam to the shaft using the 115529 Screw, 8330 Washer, and 151629 Special Nut.

(11) Replace the parts removed from the main shaft in Paragraph (9) in their same relative position.

(12) Replace main shaft assembly and disk assembly mounting screws.

(13) Replace bearing caps.

(14) Replace brush holder arm assembly and associated parts.

(15) Replace resistor 86951 (525 ohms) with 74691 Resistor (1600 ohms).

#### NOTE

When stop magnet is to operate on 115 V AC 60 or 50 cycles, no resistor will be required therefore, strap all terminals. When stop magnet is to operate on 115 V AC 25 cycles terminals 1 and 3 should be strapped with leads connected to terminals 1 and 2. When stop magnet is to operate on 115 V DC no terminals should be strapped and leads should be connected to terminals 1 and 3

(16) Add the 104669 Magnet Assembly, 85483 Spacer Plate, 104657 Gear Guard using the screws, flat washers, and lock washers retained in Paragraph (4).

#### NOTE

Armature face stamped "C" should face coil for DC operation and away from coil AC operation.

(17) Add the 136950 Stop Lever, and 136951 Latch Lever using pilot screws and lock nuts retained in Paragraph (b).

(18) Hook the 87401 Spring from the 76058 Spring Post to the 136951 Latch Lever.

(19) Hook the 49420 Spring from the spring bracket on the magnet assembly to the 136950 Stop Lever.

(20) Route cable under the magnet bracket below the armature mounting stud and tie it to the magnet bracket.

Cable should not interfere with the action of the armature.

(21) Replace base plate and covers.

### 3. ADJUSTMENTS

a. For all modification kits except the 126037 and 136154 Modification Kits refer to Teletype Bulletin 141B (Adjustments Model 14 Transmitter Distributor) and make the adjustments listed therein.

b. For the 136037 Modification Kit refer to Teletype Bulletin 189B and make the adjustments listed therein.

c. For the 136154 Modification Kit refer to Bulletin 141B with the following revisions and additions:

#### (1) Clutch Magnet Bracket

(a) When the armature is against the pole face of the magnet and the armature extension is resting on the bottom of the unlatched step of the stop lever, there should be from .002" to .006" clearance between the right edge of the unlatch step and the left edge of the armature extension.

(b) The right edge of the latch step of the stop lever shall be parallel to the left edge of the armature extension in the latched position. When the reset cam is holding the stop lever at its greatest distance from the armature extension the latch step should be from .001" to .005" away from the end of the armature extension.

(c) To adjust, loosen the clutch magnet bracket mounting screws and position the bracket. Tighten the mounting screws.

#### (2) Magnet Core Adjustment

(a) For DC operation the armature should strike both pole faces simultaneously and air gap between the armature and pole faces (when the armature is held against the pole faces) should not exceed .005". To adjust, loosen the clutch magnet core mounting screws and position the magnet core. Tighten the mounting screws.

(b) For AC operation, loosen the clutch magnet core mounting screws and position the magnet core to eliminate AC hum. Tighten the mounting screws.

#### (3) Stop Lever and Pilot Screw Adjustment

(a) With the clutch magnet de-energized and the end of the clutch shoe

lever against the stop lever, the top of the stop lever should be flush within .010" of the top of the shoe lever.

(b) To adjust, loosen the lock nuts and move the stop lever up or down as required by turning the pilot screws making sure that there is some but not more than .004" end play between the pilot screws (gauge by eye). Tighten the lock nuts securely.

(4) Reset Cam Adjustment

(a) With the armature held against the magnet poles the reset cam should clear the end of the camming leg of the stop lever when the stop lever is even with the leading edge of the clutch shoe release lever. The reset cam should ride in the center of the camming leg on the stop lever.

(b) To adjust, loosen the clamp screw on the reset cam and position the cam. Tighten the clamp screw.

(5) Armature Lever Spring Tension Adjustment

(a) With the armature extension in its latched position (armature not attracted) and the stop lever held away from the end of the armature extension, it should require a pressure of 3 to 3-1/2 ozs. to start the armature moving when the push end of an 8 oz. scale is applied horizontally to the armature between the screws.

(b) To adjust, tighten or loosen the armature torsion spring by means of the bearing stud.

(6) Stop Lever Spring Tension

(a) Hold the armature against the magnet poles making sure that the reset cam will not touch the camming leg of the stop lever, and hook an 8 oz. scale over the armature end of the stop lever. It should require 3 to 6 ozs. to start the stop lever moving.

(7) Latch Lever Spring Tension

(a) With the latching edge of the clutch disk away from the latch lever, hook an 8 oz. scale over the end of the latch lever and pull at a right angle to the lever, it should require 2 to 3 ozs. to start the lever moving.

(8) Lubrication

(a) Standard lubrication in Bulletin No. 141 applies. The following numbers should be added or replace like numbers:

(14) Stop lever - apply oil - grease - oil to bearings, latching step, the point of engagement with the shoe release lever, and the camming surface.

-18-  
(5787S)

- (26) End of armature lever and armature bearing - grease - oil.
- (27) Entire length of armature retractive spring - grease.

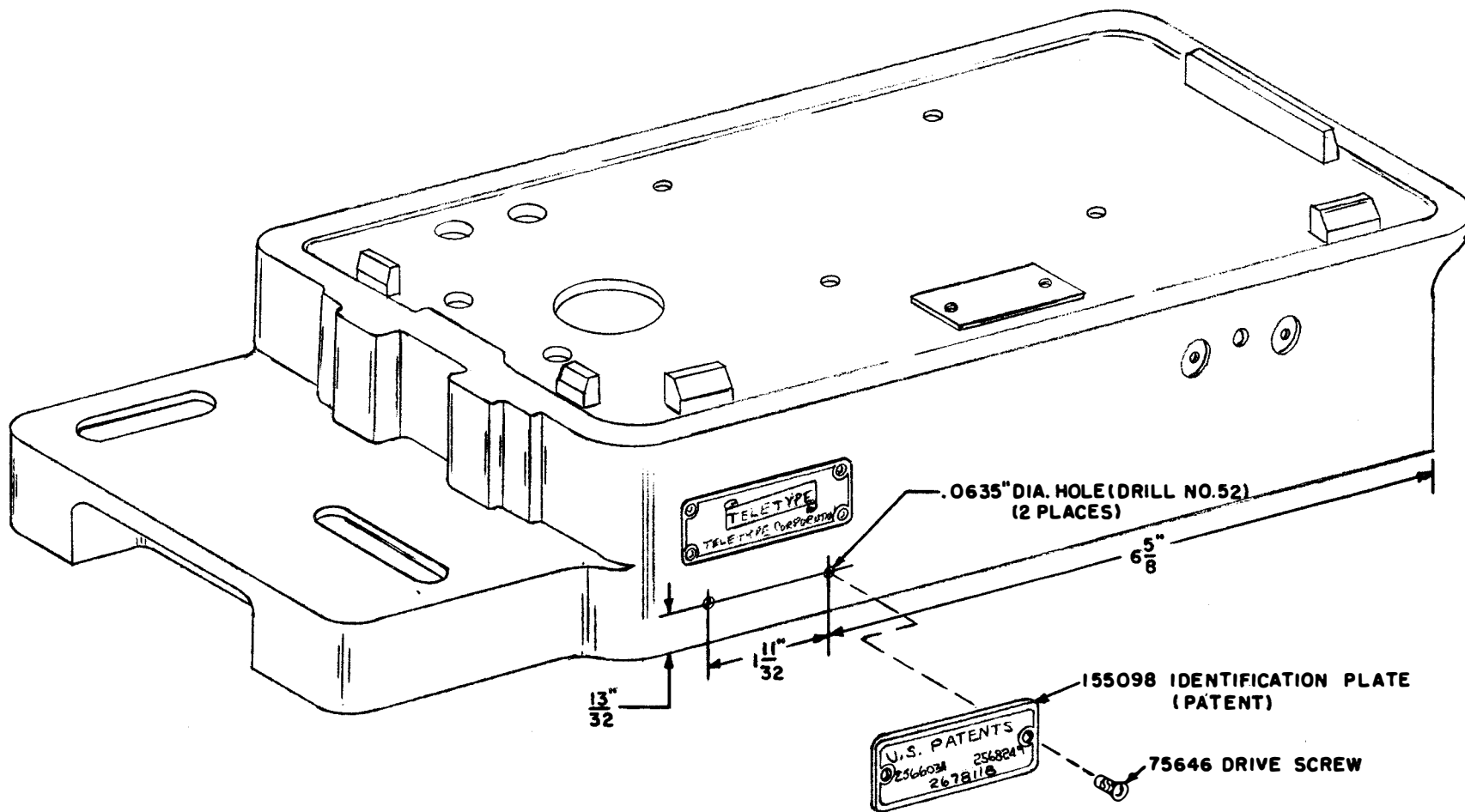

FIGURE 1

