

INSTRUCTIONS FOR INSTALLING THE 153924 UPPER CASE BLANK-H MOTOR CONTROL CONTACT MECHANISM MODIFICATION KIT, AND THE 153948 TIME DELAY MOTOR STOP DISABLER MODIFICATION KIT ON A MODEL 28 TYPING UNIT LP6, LP8, LP9 (BELL SYSTEM 28E, 28F, 28G)

1. GENERAL

a. The 153924 modification kit when installed on a Model 28 Typing Unit LP6, LP8 or LP9 (Bell System 28E, 28F, 28G) equipped with an AN stunt box and having two, twenty terminal connectors, provides an upper case Blank-H motor control contact mechanism.

b. The 153948 modification kit when installed on a Model 28 Typing Unit LP6, LP8 or LP9 (Bell System 28E, 28F, 28G) equipped with an AN stunt box and with the 153924 modification kit (see Paragraph 1.a. above) provides a time delay motor stop disabler mechanism. The disabler is effective on receipt of carriage return and deactivated on receipt of the motor stop sequence (Upper Case Blank-H for Bell System Units).

c. The 153924 modification kit consists of:

2	4703	Spring	1	154647	Lever
2	72522	Wick	1	155247	Function Bar Blank
2	90517	Spring	1	155288	Function Bar H
1	152121	Lever	*2	155751	Sleeve, Insulating
2	152653	Pawl	*1	<del>157074</del>	Switch Assembly 172504
1	152660	Plate, Spring	1	157105	Cable Assembly
1	154613	Latch	2	157240	Spring

d. The 153948 modification kit consists of:

1	3599	Nut 4-40 Hex.	1	152357	Stud
1	4703	Spring	1	152653	Pawl
1	72522	Wick	1	152667	Function Bar C-R
1	90517	Spring	2	157240	Spring
1	110743	Washer, Lock	*1	157889	Spring
1	152089	Latch	*1	157899	Arm, Contact
1	152298	Lever	*1	155751	Sleeve, Insulating

e. For part numbers referred to and for parts ordering information see Teletype Model 28 Printer Parts Bulletin.

## 2. INSTALLATION

**NOTE:** The following instructions are for installations in a selective calling typing unit equipped with stunt box arrangement AN, and having two twenty terminal connectors. For installation in selective calling units containing other stunt box arrangements, use any available adjacent slots outside of the release bail limits (do not use slots reserved for standard functions such as line feed, keyboard lock, etc. unless the unit is not equipped with the respective tie bar slide) within the limits of the cable assembly.

### a. 153924 Modification Kit (Figure 2-68)

For installation in selective calling units equipped with only one twenty terminal connector, connect the contact to terminals 5 and 8 of this connector. No modification of the cabinet wiring is required for the above.

- (1) Remove the typing unit from the keyboard or base.
- (2) Remove the 151627 rod from the typing unit frame.
- (3) Rotate the function clutch until the stripper blade driving arm is in its lower position, remove the screw from the drive arm collar and disconnect the drive arm from the drive link.
- (4) Loosen the stunt box cable bracket screw and rotate the 154872 bracket counter clockwise.
- (5) Remove the stunt box cable clamp from the connector bracket.
- (6) Remove the two screws that secure the right connector.
- (7) Raise the right connector sufficiently to permit removal of the right connector insulator.
- (8) With the cable away from the 154872 cable bracket, rotate the bracket clockwise and tighten the screw.
- (9) Remove the two screws that secure the stunt box assembly in the typing unit.
- (10) Lift the stunt box assembly upward to disengage it from its locating brackets and pull toward the rear.

**CAUTION:** Raise the stunt box as it is pulled to the rear to insure that the line feed stripper slide clears the side frame ear.

- (11) Remove the 153295 stripper blade driving shaft as follows:
  - (a) Remove the 151637 screws from the 153294 stripper blade driving cams.
  - (b) Remove the two 119653 retaining rings.
  - (c) Slide the 153295 shaft through the stunt box side frame.
- (12) Remove either the right or left 153301 stripper blade cam arm.
- (13) Remove the 155061 stripper blade.
- (14) Remove the 153581 rear handle.
- (15) Place one 152653 pawl in slot 32 and one in slot 33.
- (16) Insert the 72522 wicks into the 157240 spring. Hook the springs between the pawls and the 152651 spring guideplate.
- (17) Insert the 155247 function bar into slot 32, and insert the 155288 function bar into slot 33.
- (18) Hook the 4703 springs between the function bar spring hooks and the 152651 spring guide plate.
- (19) Remove the 152889 shaft retainer plate, and the upper 150547 shaft; replace the 151657 shaft retainer plate screw. Loosen the three 150689 shaft guide blocks.
- (20) Place the 90517 springs into the function lever spring holes. Insert the 154647 function lever and 152660 spring plate into their respective position in slot 33. Hook the 90517 spring to the 152660 spring plate.
- (21) Insert the 152121 function lever and 154613 latch into slot 32. Hook the 90517 spring in the 154613 latch spring hole.
- (22) Tighten the three 150689 shaft guide blocks.
- (23) Replace the 150547 shaft; remove the 151657 shaft retainer plate screw, and replace the 152889 shaft retainer plate.
- (24) Replace the 153581 handle, the 155061 stripper blade, the 153301 stripper blade cam arm, and the 153295 stripper blade driving shaft, including the 153294 stripper blade driving cams, the 4586 felt washers, the 153291 stripper blade driving arm, and 119653 retaining rings.

\* (25) Remove and discard the 151880 nuts, which are used for handling purposes only, from the 157074 switch assembly. Place the 157074 switch assembly into position on top of the stunt box and secure in position with the 151689 screws and 110743 lock washers which are included in the 157074 switch assembly.

NOTE: Check to see that the contact arm insulator is in alignment with the function lever in slot 33. If necessary, loosen the screws and position the switch to meet the requirement. Check to see that there is some clearance between the contact arm and vertical face of the clip when the play in the arm is taken up to make the clearance minimum.

\* (26) Solder the 157105 cable to the 157074 switch assembly in accordance with Figure 1. Use a minimum amount of solder taking care not to allow flux to flow around the contact surfaces. The two 155751 insulating sleeves are to be used at the end where the cable is soldered to the typing unit connector. The black wire of the 157105 cable is to be utilized when the Time Delay Motor Stop Disabler Contact is used and therefore should be taped and tied to the cable when not in use.

NOTE: Care should be exercised when soldering, lacing, or routing the cables so as not to tug or pull unnecessarily on the contact spring causing distortion or damage to the spring.

\* (27) Place a 155751 insulating sleeve over each lead of the cable before soldering the wires to the connector terminals. Solder the 157105 cable leads to the typing unit connector on the right side of printer in accordance with Figure 1. Slide the tubing over the terminals after soldering.

(28) Reinstall the stunt box.

CAUTION: Raise the line feed stripper slide sufficiently to clear the side frame ear when installing the stunt box.

Raise the single-double line feed stripper bail, when installing the stunt box, so that it rests on the line feed stripper slide.

(29) Lace the 157105 cable to the present stunt box cable(s), routing the cable under the 154872 bracket.

(30) Connect terminals 45 and 46 of the auxiliary cabinet terminal block to terminals 32 and 33 respectively of the rear cabinet terminal block. See Figure 2.

b. 153948 Modification Kit (Figure 2-69)

NOTE: For installation in selective calling units equipped with only one twenty point connector, one slide of the contact may be connected to terminal 16; the other side must be strapped to the terminal of the motor stop contact which is connected to terminal 5 of the typing unit connector. The blue lead must be moved from terminal 32 to 28 of the rear cabinet terminal block. If the unit is equipped with a reperforator control contact, terminal 16 of the typing unit connector and terminal 28 of the cabinet can not be used. In which case use any available typing unit terminal that terminates at the cabinet terminal block.

- (1) Follow procedure in Paragraphs 2a, (1) and (2).
- (2) Remove the stunt box. To remove the stunt box follow the procedure in Paragraphs 2.a. (3) through 2.a. (14).
- (3) For typing units equipped with an AN stunt box and with two, twenty terminal connectors, place the 152653 pawl in slot 34. For other than an AN stunt box place the 152653 pawl in the slot adjacent (higher numbered) to the 153924 motor control contact mechanism set of parts.
- (4) Follow procedure in Paragraph 2.a. (16).
- (5) For typing units equipped with an AN stunt box and with two, twenty terminal connectors, insert the 152667 function bar into slot 34.
- (6) Follow procedure in Paragraphs 2.a. (18) and (19).
- (7) Place the 90517 spring into the function lever spring hole. Insert the 152298 function lever and 152089 latch into slot 34. Hook the spring in the latch spring hole.
- (8) Follow procedure in Paragraphs 2.a. (22) and (23).
- (9) Assemble the 152357 stud, 3599 nut, and 110743 stud to the 154647 function lever in the adjacent slot (lower numbered). The threaded portion of the stud is to extend to the left.
- (10) Follow procedure in Paragraph 2.a. (24).
- \* (11) Install the 157889 contact spring and 157899 contact arm in the 157074 switch (installed with the 153924 modification kit) as follows:
  - (a) Remove the two 151689 screws and 110743 lock washers which secure the switch to the stunt box.
  - (b) Unsolder existing connections to the terminal and spring. Care should be exercised when unsoldering the 157105 cable to the contact spring and also when lacing or routing the cable so as not to tug or pull unnecessarily on the contact spring to prevent distortion or damage to the spring.

(c) Remove the 157891 top plate with the 157889 spring and 157887 contact arm.

(d) Install the 157889 contact spring into the terminal plate position adjacent to the spring already mounted in the terminal plate by placing the loop end of the spring into the required position in the terminal plate. Hook a spring hook in the loop of the spring and pull the spring into position.

(e) Before mounting the contact plate on the switch block, check to make sure the end of the spring is on top of the formed over contact end. Mount the terminal plate with springs and the block in the previous location from which it was removed on the stunt box and secure in place with the 151689 screws and 110743 lock washers.

(f) Resolder the 157105 cable previously removed.

(g) Insert the pointed end of the 157899 contact arm with the notch of the contact arm in the downward position between the bent up end of the spring and formed end of the contact. Push the arm in position so the notch is fully engaged. Also reinstall the above 157887 contact arm which was removed in the same manner.

(h) Check to see that the contact arm insulators are in alignment with the function lever. If necessary, loosen the screws and position the switch to meet the requirement. Check to see that there is some clearance between the contact arm and vertical face of the clip when the play in the arm is taken up to make the clearance minimum.

\* (12) Solder the black wire of the 157105 cable to the switch terminal as shown in Figure 1. Place the 155751 insulating sleeve over the lead of the cable before soldering the black wire to the connector terminals. Solder the other end of the wire to terminal 7 of the auxiliary typing unit connector on the right side of printer. Slide the tubing over the terminal after soldering. Strap the contact arm springs of the Time Delay Motor Stop Disabler and Motor Control Contact Mechanism.

NOTE: Use a minimum amount of solder, taking care not to allow flux to flow around the contact surfaces.

(13) For typing units equipped with one, twenty terminal connector, connect one side of the contact to terminal 16; strap the other side of the contact to the motor stop contact terminal which is connected to terminal 5 of the typing unit connector.

NOTE: If the unit is equipped with a reperforator control contact, terminal 16 of the typing unit connector and terminal 28 of the cabinet can not be used; use any available typing unit terminal that terminates at the cabinet terminal block.

(14) Follow procedure in Paragraph 2.a. (28).

(15) Remove the blue lead from terminal 32 of the rear cabinet terminal block and connect to terminal 28.

NOTE: The green lead on terminal 28 is connected to terminal 16 of the left typing unit connector and need not be removed unless the typing unit terminal (16) is in use.

(16) Connect terminal 47 of the auxiliary cabinet terminal block to terminal 28 of the rear cabinet terminal block. See Figure 2.

\*3. ADJUSTMENTS

For standard adjustment procedure refer to standardized adjustment information. Check the following adjustment.

Stunt Box Switch Spring Tension (For Switches Equipped with a Block and Separate Top Plate)

With the switch contact arm in its closed position, hook an 8 oz. scale under the contact arm adjacent to the contact arm insulator and pull up. It should require 1 to 2 ozs. to open the switch contact.

\* \* \*

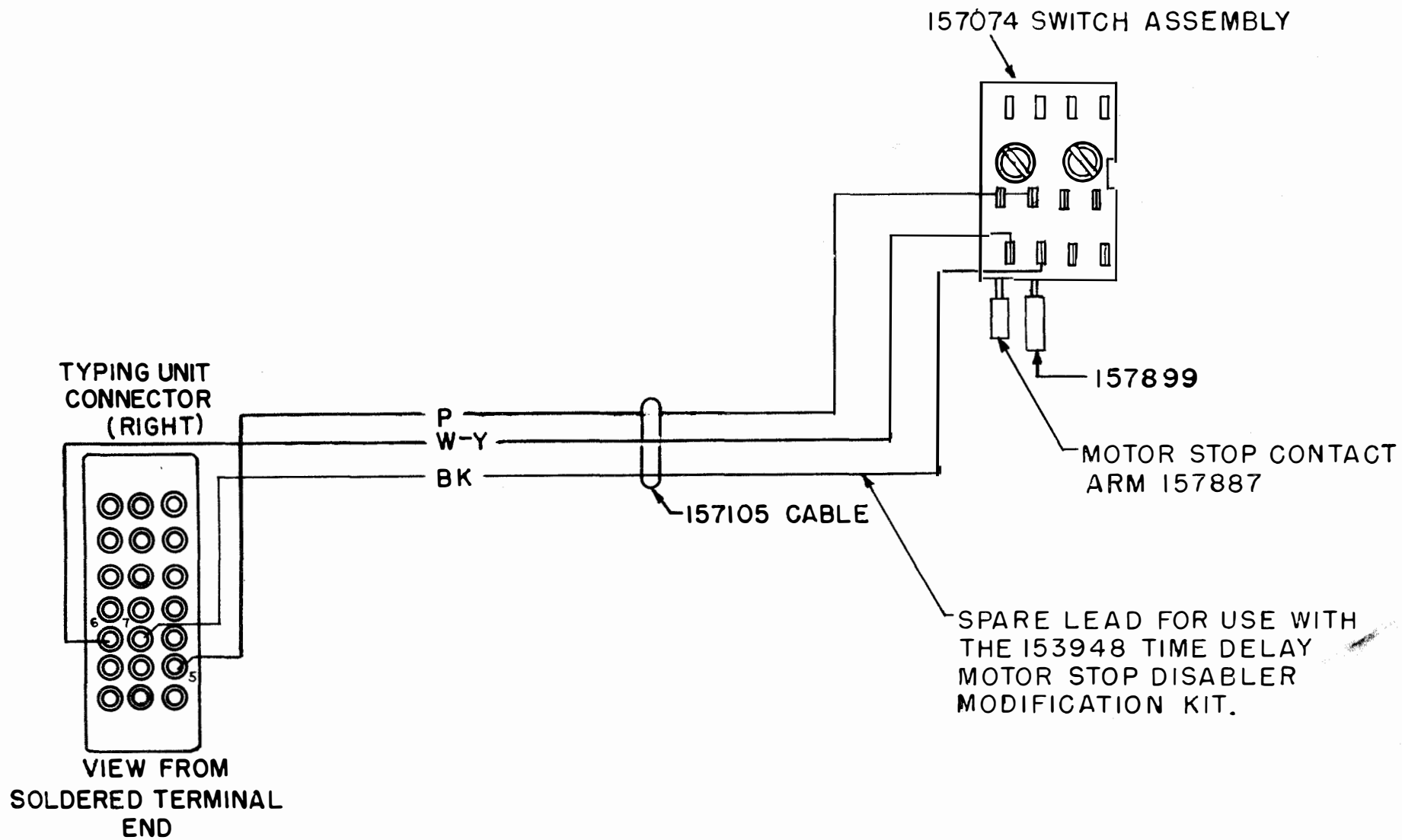

FIGURE 1



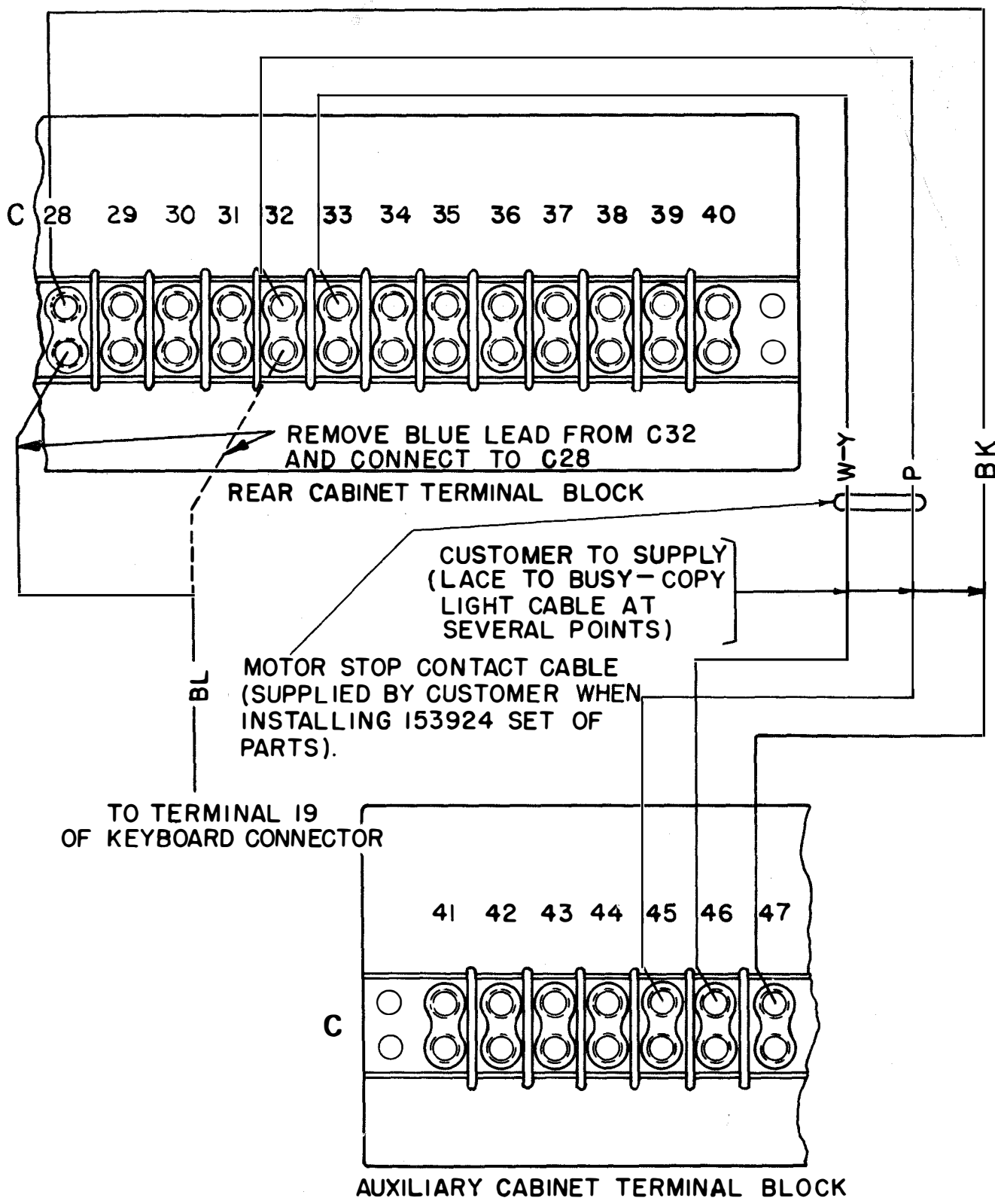

FIGURE 2

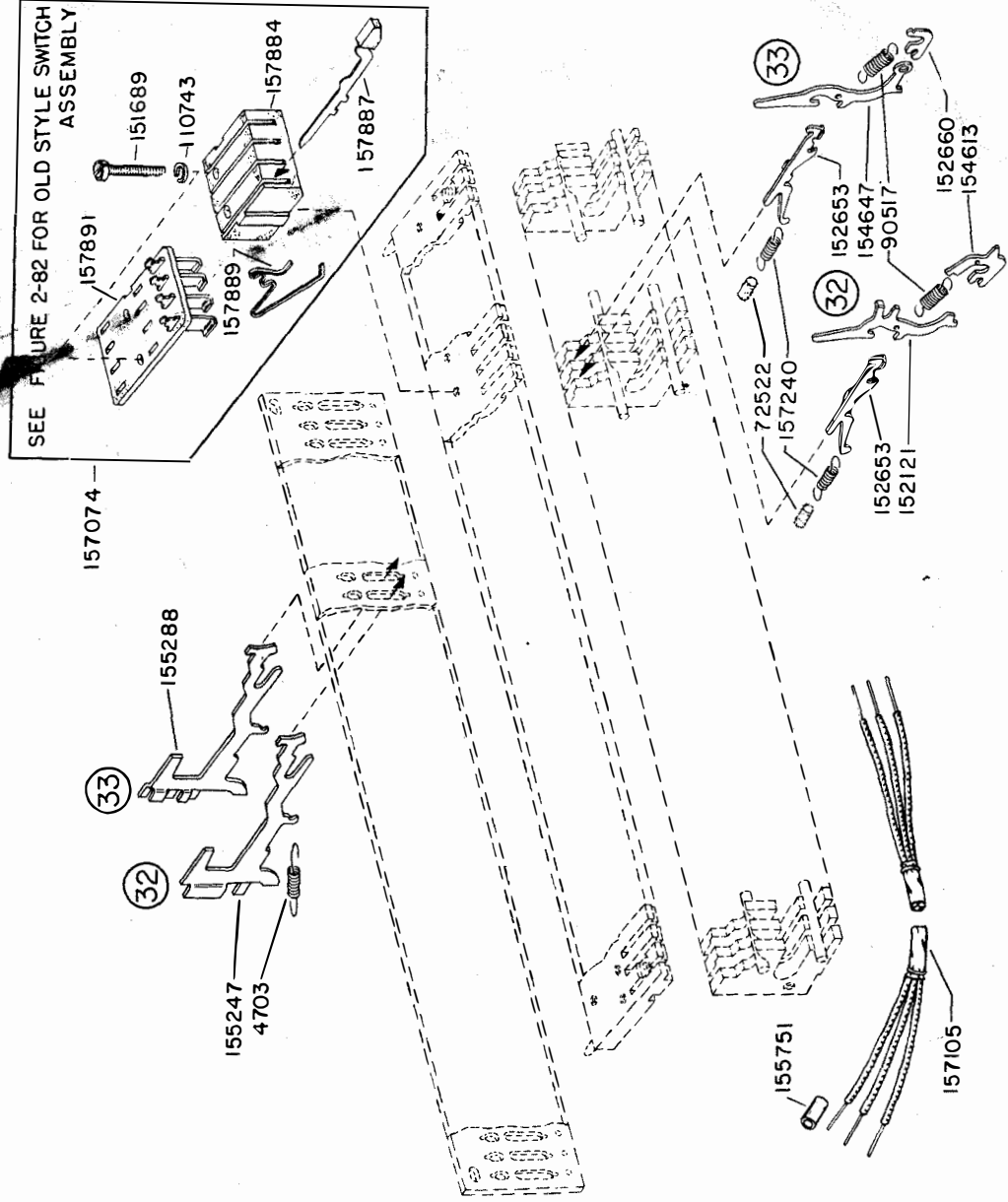

FIGURE 2-68 153924 MODIFICATION KIT TO PROVIDE UPPER CASE-BLANK-H MOTOR CONTROL

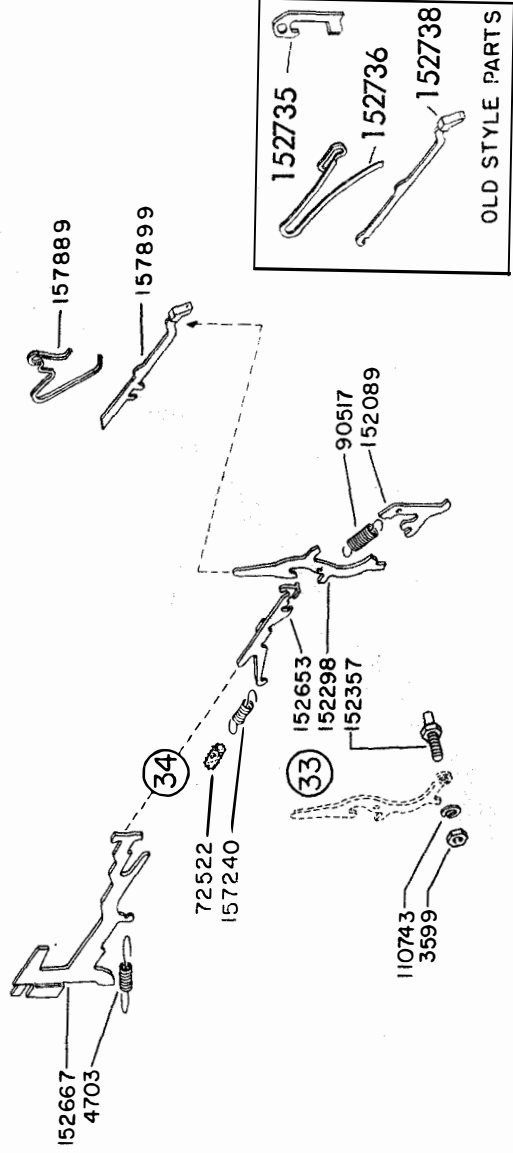

FIGURE 2-69 153948 MODIFICATION KIT TO PROVIDE TIME DELAY MOTOR STOP DISABLER