

INSTRUCTIONS FOR INSTALLING MODIFICATION KIT
164502 TO PROVIDE MODEL 28 AUTOMATIC SEND-RECEIVE
KEYBOARD BASE (LAK) WITH AN END-OF-MESSAGE
CHARACTER GENERATOR; AND INSTRUCTIONS FOR
INSTALLING MODIFICATION KIT 173122 TO ELIMINATE
INTERFERENCE BETWEEN COMPONENTS OF MODIFICATION
KIT 164502 (EARLY DESIGN) AND CODEBAR RESET BAIL 162308

The chart below pertains to Bell System only:

Teletype Unit	Bell Code	Bell System Reference
Send-Receive Keyboard with Perforator	28A, 28B 28D, 28E 28F, 28G 28G-1	Perforator Transmitter Base

1. GENERAL

- 1.01 Modification kit 164502 provides a Model 28 automatic send-receive keyboard base (LAK) with an end-of-message character generator.
- 1.02 The kit permits automatic insertion of the end-of-message sequence in the perforated tape or on the typed page of the page printer. It performs the same functions as the keyboard when the K-KT-T keyboard switch is in each of the following positions:
- K Position - The character generator transmits the end-of-message sequence to the signal line.
 - KT Position - The character generator transmits the end-of-message sequence to the signal line and perforates either typed or untyped tape.
 - T Position - The character generator is mechanically blinded from the signal line but perforates typed or untyped tape.

SPECIFICATION 5954S

1.03 The end-of-message character generator has no provision for controlling the character counter stepping and carriage return codebars. Therefore, the counter may not step or reset during character generator operation.

1.04 Modification kit 164502 has a total capacity of 21 characters. The first character transmitted must always be a LETTERS combination; the remaining 20 may be any characters desired. The arbitrary characters are determined by detachable code blades set in a code drum. The entire code drum may be replaced with the aid of a spring hook. Since projections on the code blades are used to rotate the drum, all of its 21 slots must be occupied by a blade.

Note: The first character transmitted is determined by a special stop code blade (LETTERS combination). Although only one such blade is included with this kit, the code drum can be equipped with any number of stop code blades to reduce the number of characters in the end-of-message sequence. To maintain a uniform message, the number of stop code blades used must be three or seven. Three stop blades equally spaced about the code drum would result in a message of six arbitrary characters preceded by the LETTERS combination. Seven stop code blades equally spaced about the code drum would result in a message of two arbitrary characters preceded by the LETTERS combination.

1.05 Modification kit 164502 end-of-message sequence is initiated from the keyboard by momentarily depressing the end-of-message (EOM) key. This action closes a pair of electrical contacts and mechanically locks the keyboard by means of a locking codebar. The movement of the locking bar closes another pair of electrical contacts and completes an electrical circuit to the trip magnet of the character generator mechanism. Operation of the trip magnet actuates the mechanism and all 21 characters are transmitted by the keyboard signal generator and/or perforated in tape as indicated in 1.02. Upon the completion of the 21st character, the mechanism is automatically reset by means of the stop code blade. Before keyboard transmission can be resumed, the keyboard must be manually unlocked by depressing the SEND keylever.

1.06 Modification kit 173122 eliminates interference between components of modification kit 164502 (early design) and codebar reset bail 162308.

Note: Modification kit 164502, at the present time, does not interfere with the codebar reset bail 162308. Modification kit 164502 (early design) containing the lever 164139, spring post 164141, and link 164159 requires the modification kit 173122 to eliminate interference with codebar reset bail 162308.

1.07 Modification kit 164502 consists of:

<u>Qty</u>	<u>Part No.</u>	<u>Description</u>	<u>Qty</u>	<u>Part No.</u>	<u>Description</u>
1	1178	Screw	2	2191	Lockwasher

<u>Qty.</u>	<u>Part No.</u>	<u>Description</u>	<u>Qty.</u>	<u>Part No.</u>	<u>Description</u>
1	3598	Nut	1	163979	Lever, function
2	3599	Nut	1	164129	Answer-back
2	7002	Washer, flat			parts, common
1	45815	Lockwasher	1	164496	Bail
1	71073	Washer, flat	1	164497	Eccentric
1	93117	Lockwasher	1	164499	Bar, locking
2	110743	Lockwasher	1	164500	Cable assembly,
1	112626	Nut			resistor
2	121473	Stud			mounting
1	151632	Screw	1	309507	Contact assembly
1	154125	Spring	1	309508	Bracket, left
4	155753	Sleeve, insulating	1	309509	Bracket, right
2	156740	Screw	1	309510	Bar, retainer
1	163106	Keylever assembly (EOM)	1	321727	Guide

Modification kit 173122 consists of:

1	173028	Post, spring	1	173095	Link
1	173029	Lever, w/hub latch operating	1	173096	Stud, eccentric

1.08 For part numbers referred to and for parts ordering information, see Teletype Model 28 Automatic Send-Receive Set Parts Bulletin 1169B.

2. INSTALLATION

Note: Refer to Teletype Model 28 Perforator Transmitter Bulletin 250B for removal of major components and assemblies.

INSTALLATION PROCEDURES

- 2.01 Remove the keyboard from the cabinet in accordance with standard practice.
- 2.02 Remove the signal generator from the keyboard in accordance with standard practice.
- 2.03 Remove the keylever guideplate from the keyboard in accordance with standard practice.
- 2.04 Remove and discard plastic plug 154197 and speed nut 117608 from the keytop hole, sixth from the left in the top row.

SPECIFICATION 5954S

- 2.05 Maneuver function lever 163979 into the 21st slot of code lever guide 154070 until it is fully seated on codebar lever shaft 154016.
- 2.06 Install a spring 154125 on function lever 163979 and code lever guide 154070.
- 2.07 Replace the keylever guideplate on the keyboard in accordance with standard practice. Readjust the spacebar bail pivot. Do not replace the keyboard hood at this time.
- 2.08 Remove lock ball retainer clamp 111343 from its present position in the center of lock ball channel 154175 and install it in the position immediately to the right of center. Some keyboards may not have a lock ball retainer clamp in the center of the lockbar channel. If so, disregard this paragraph.
- 2.09 Install keylever assembly (EOM) 163106 in the keytop guide hole previously unplugged, snapping onto the function lever 163979 previously installed in this position (Figure 2).
- 2.10 Remove screw 151631, lockwasher 2191, and flat washer 7002 which fasten lock ball channel 154175 to left frame mounting bracket 154210. Refasten the channel to the bracket using stud 121473 instead of screw 151631 (Figure 2).
- 2.11 Remove screw 151631, lockwasher 2191, and flat washer 7002 which fasten lock ball channel 154175 to right frame mounting bracket 154211. Refasten the channel to the bracket using stud 121473 instead of screw 151631 (Figure 2).
- 2.12 Check and, if necessary, make the lock ball channel adjustment. Refer to Teletype Model 28 Bulletin 250B.
- 2.13 Place brackets 309508 and 309509 on top of each stud 121473, and assemble friction tight with two screws 156740, lockwashers 2191, and flat washer 7002 (Figure 2).
- 2.14 Install retainer bars 309510 on top of brackets 309508 and 309509 and assemble friction tight with two screws 156740, lockwashers 110743, and nuts 3955 (Figure 2).
- 2.15 Install contact assembly 309507 on retainer bar 309510, and assemble friction tight with guide 321727, screw 1178, flat washer 71073, lockwasher 93117, and nut 112627. Move the contact assembly along the retainer bars until it is beneath the function lever 153979 previously installed (Figure 2).
- 2.16 Place the keyboard control switch in the K keyboard position.
- 2.17 Remove the lockbar contact assembly and its cover 158299 from the keyboard. Do not disconnect any wires at this time.

- 2.18 Remove screw 151631 and lockwasher 2191 which fasten the front of codebar guide 154008, bracket 158226, and bracket 158230 to the right side code lever guide bracket 154068. Loosen the rear mounting screw 151631 so that it is friction tight.
- 2.19 Pivot bracket 158226 upward so that its attached lever 158228 disengages the slot in lockbar 158010.
- 2.20 Remove screw 151630 and lockwasher 2191 which fasten the front of the codebar guide 154008 and stop bracket 158063 to the left side code lever guide bracket 154069. Loosen rear mounting screw 151630 so that it is friction tight.
- 2.21 Pivot bracket 158063 downward so that its stop clears only lockbar 158010.
- 2.22 Slide lockbar 158010 to the right until it clears the right side codebar guide 154008. Disengage the lockbar from lockbar latch 154023 and lift it upward and to the left so that it is removed from the code lever guide assembly. Discard lockbar 158010.
- 2.23 Replace lockbar 158010 with lockbar 164499 reversing the procedure outlined in Paragraphs 2.17 through 2.22. Readjust the codebar guide clearance per Teletype Model 28 Bulletin 250B.
- 2.24 Install eccentric 164497 on bail 164496 with lockwasher 45815 and nut 112626 (Figure 3).
- 2.25 Remove the three screws 109152 and lockwashers 110743 which fasten rear blade 154184 to universal bail. Remove the blade.
- 2.26 Remove nut 3598, lockwasher 2191, and flat washer 7002 which fasten cable clamp 121242 to line break switch cable 154149. Also remove two screws 153841 and lockwashers 2191 which fasten line break switch bracket 154039 to the keyboard.
- 2.27 Remove two retaining rings 119653 from the left side of function lever shaft 154092. Slide the shaft to the right until its left end is approximately in line with the roller on universal extension 154239 mounted on universal bail 154179. Note the position of all function lever thus removed from the shaft so that they may be readily replaced.
- 2.28 Rest the keyboard on its back side so that it is supported by the motor. From the bottom of the keyboard maneuver bail 164496 with eccentric 164497 into its proper position on function bail bracket 154059. Hold the bail with its long extension upward and its bearing holes at right angles to shaft 154092. Insert the long extension of the bail upward through the base cutout in line with the previously installed function lever (EOM) 163979. Position bail extension 164496 so that it engages function lever

SPECIFICATION 5954S

163979 in a similar manner as local carriage return function bail 154099 engages its associated function lever. Place bail 164496 in the function bail bracket slot immediately to the left of function lever 163979 so that eccentric 164497 is atop the keyboard lock function lever 154067. Slide shaft 154092 to the left into the bearing holes of bail 164496 and all original function levers previously disengaged. Secure shaft 154092 with two retaining rings 119653 previously removed (Figure 3).

- 2.29 Replace the parts previously removed in Paragraph 2.25. Make the following keyboard lock adjustment at this time:

Keyboard Lock Bail Eccentric (See Figure 3)

- 2.30 Replace eccentric stud 154017 in codebar bail 162308 with eccentric stud 173096. Fasten stud 173096 with the original collar 8449, lockwasher 2191, and nut 154127 (Figure 4).

- 2.31 Unhook codebar bail latch spring 154191 from spring post 154089. Remove stud 154079 with codebar bail latch 158268 or 178493, spring 154191, felt washer 115122, and retaining ring 119651 from signal generator rear plate 154102. Remove the latch, spring, felt washer, and retaining ring from the stud. Discard the stud. Install the latch, its spring, and felt washer on stud 164138. Reassemble the stud on the signal generator rear plate. Maneuver latch operating lever 173029 onto stud 164138 so that it extends through the cutout in the codebar bail with its hub adjacent to latch 158268 or 178493 and its right side projection overlapping the latch. Retain lever 173029 and latch 158268 or 178493 on stud 164133 with original retaining ring 119651 (Figure 4).

- 2.32 Unhook codebar bail spring 154215 from spring post 154089. Remove spring post 154089 from signal generator rear plate 154102 and replace it with spring post 173028. Replace the codebar bail spring 154215 and codebar bail latch spring 154191 on spring post 173028. Place latch operating lever spring 76422 on lever 173029 only. Spring 76422 should be placed on post 173028 after the character generator mechanism has been installed on the keyboard (Paragraph 2.50 and Figure 4).

- 2.33 Install screw 150089 and locknut 151880 in the tapped hole located on the right side of latch operating lever 173029 (Figure 4).

- 2.34 Replace the signal generator on the keyboard in accordance with standard practice. Check and, if necessary, make the codebar and code lever clearance, the codebar bail, the codebar bail and nonrepeat lever clearance, the universal bail latchlever, the universal bail extension, the ball wedgelock and ball track clearance, and the lock ball endplay adjustments. See Teletype Model 28 Bulletin 250B. The codebar bail adjustment must be checked for both the keyboard and perforator mechanisms of the LAK.

- 2.35 Remove and discard the keytop arrangement identification screw 151739 and retain lockwasher 2191 from the keyboard.

- 2.36 Install mounting bracket 164142 on the keyboard so that it is offset toward the top. Use the two mounting holes located on the left side of spring post 156574 on universal bail 154179. Fasten the bracket with two screws 151722, one lockwasher 2191, furnished with the kit, and one lockwasher 2191 removed in preceding paragraph (Figure 5).
- 2.37 Place O-ring 164162 in the groove on the rim of message drum 164161 which is furthest from the slot in the center portion of the drum. Install stop blade 164163 in any slot position in the drum by first inserting the blade under the O-ring and then rotating the blade toward the center of the drum until it is fully seated (Figure 6).
- 2.38 Code the drum in the following manner (Figure 6):
- (a) Almost any end-of-message desired may be selected as long as it does not contain more than 21 characters including spaces. However, the coding of the message drum always begins with a LETTERS (stop blade) and is normally followed by CARRIAGE RETURN and LINE FEED; the coding also normally ends with CARRIAGE RETURN and LINE FEED. This arrangement insures that the message will appear at the beginning of a line on the distant teleprinter and that over-printing of the message will not occur. Transmission of the LETTERS code combination at the beginning of the message also returns all teleprinters in the circuit to the unshift position. Since 5 of the 21 available characters are used to perform these functions, only 16 are available for the message. Of course, this procedure may be altered to suit a particular application of the end-of-message character generator feature.
 - (b) Code the drum in a counterclockwise direction beginning with the number 2 code blade 164164 adjacent to stop blade 164163. Each code blade 164164 is provided with removable tines for all levers of the transmission code (1,2,3,4,5). An O code level tine has been provided on each blade for future usage on six level keyboards and currently may be disregarded. A blade is coded by breaking off the unwanted tines at the scored line at the base of each tine. Figure 6 indicates which tines are to be removed for a particular character. To prevent distortion of a code blade, each blade should be held securely near the score mark of the tine to be removed. Although twenty code blades are sufficient to completely code the drum, twenty-five such blades have been provided to allow for possible errors in coding. Since each slot position in the drum must be occupied by a code blade, the unused characters under the twenty permitted for customer use shall be coded either for LETTERS or BLANKS or any tolerable character.
 - (c) Install each coded blade 164164 in the proper slot position in the drum by first inserting the blade under the O-ring and then rotating the blade toward the center of the drum until it is fully seated. After filling the code drum, encircle the code blades by placing another O-ring 164162 in the groove on the opposite rim of drum 164161.

SPECIFICATION 5954S

- 2.39 Apply a thin film of grease on the shaft of drive plate 164165. Install the message drum complete with coded blades and O-rings on the shaft of the drive plate. Depress the stepping pawl extension to raise pawl so that the drum bears against the hub on the drive plate and the pawl fully engages the projections of the code blades. Hold the assembled parts, approximately as indicated in Figure 7, by means of the thumb and first two fingers of the left hand. Slide the drive plate shaft downward along the left sides of the curved slots in side plates 164144 until the drum assembly is fully seated as indicated.
- 2.40 To facilitate the adjustment of the character generator mechanism, the magnet yoke and stop lever latch adjustments should be made before the mechanism is installed on the keyboard. See Figures 10 and 11 for adjustments.
- 2.41 After making the magnet yoke and stop lever latch adjustments, remove the message drum by reversing the procedure used in its installation. The character generator mechanism may now be installed on the keyboard. Unfasten the screw which secures the cable lamp for the tape backspace button switch cable to the top of keyboard. With the parts assembled as indicated in Figure 5, maneuver the character generator mechanism so that the left side projection of stop lever 164146 is under screw 150089 fastened to latch operating lever 173029, the front portion of mounting plate 164143 is resting on the keyboard base under the previously loosened cable clamp and the rear portion of plate 164143 is resting on mounting bracket 164142. Assembly mounting plate 164143 friction tight to the keyboard and bracket by means of two screws 153537, lockwashers 2191, and flat washer 7002 placed in the rear and right front mounting slots of the plate. Reassemble the previously loosened cable clamp friction tight to the keyboard by using its original mounting screw in the left front mounting slot of plate 164143 (Figure 5).
- 2.42 To facilitate the adjustment of the character generator mechanism, the mounting plate adjustment should be made when the mechanism is being installed on the keyboard after the signal generator has been replaced. See Figure 12 for adjustment.
- 2.43 Install resistor mounting cable assembly 164500 on lock ball channel 154175 or 163647 by means of the mounting hole on the right side of the channel. Use a screw 151632, flat washer 7002, lockwasher 2191, and nut 3598 to secure the assembly (Figure 8).
- 2.44 Connect the wires associated with resistor mounting cable assembly 164500 as indicated in Figure 9. Temporarily remove the end-of-message keylever switch from retainer bar 309510 to facilitate the soldering of the white-red (W-R) wires to it. Replace the switch and tie the white-red and white-green wires to the retainer bar. Disconnect the existing black wire from terminal number 1 of the lockbar switch; tape and tie back the wire. Disconnect the existing green wire from terminal number 2 of the lockbar switch; tape and tie back the wire. Connect the red (R) and white-red (W-R) wires of cable assembly 164500 to the lockbar switch as indicated. Route the white-blue (W-BL) and white-orange (W-O) wires to the character generator trip magnet; connect them

as indicated. Tie the wires to the rear of the magnet yoke making certain that they do not interfere with any moving parts on the character generator of keyboard. Route the blue (BL) and red (R) wires to the motor terminal block, connect them as indicated. Use tubing 155750 and 155753 as indicated.

2.45 Check, and if necessary, make the keyboard lockbar switch adjustment. (Refer to Model 28 Adjustment Bulletin 250B.) Also, make the following end-of-message (EOM) keylever switch adjustments (Paragraph 3 and Figure 2):

Keylever Switch Horizontal Adjustment

Keylever Switch Vertical Adjustment

2.46 Assemble drive links 173095 and 164160 together as indicated in Figure 7. Use two screws 151152, lockwashers 3640, and flat washers 125011 to assemble the part friction tight. Install the assembled drive links to the appropriate shoulder of code bail reset eccentric stud 173096. Rest link 164160 along the rear side of the front side plate 164144 of the character generator. Install spring 90573 in the spring eye of link 164160.

2.47 Install the drive plate assembly without the message drum on the character generator mechanism as previously described. Hook spring 90573 on eccentric stud 164169 making certain that the slot in drive link 164160 engages the stud on the drive plate.

2.48 Make the drive link (Figure 13) character generator adjustment at this time.

2.49 Unhook drive link spring 90573 from eccentric stud 164169. Disengage the slot in drive link 164160 from the stud on drive plate 164165. Remove the drive plate assembly from the character generator mechanism. Install the message drum on the drive plate shaft and install the drum and drive plate assembly on the mechanism as previously described. Rehook spring 90573 on stud 164169. Make certain that the slot in drive link 164160 engages the stud on the drive plate; if necessary, turn the drive plate with its attached stepping pawl held out of the engagement with the code blades so that the parts are properly aligned.

2.50 Make certain that stop lever 164146 is latched on latch 164158. Install spring 76422 for the codebar bail latch operating lever on post 173028.

2.51 Make the following final character generator adjustments:

Stepping Pawl (Figure 14)

Latch Operating Lever Adjusting Screw (Figure 15)

2.52 Make certain that stop lever 164146 is latched on latch 164158 and also, that the signal generator clutch is disengaged. Turn the message code drum clockwise until, in its fully detented position, sensing levers 164154 are resting on stop blade 164163, which

SPECIFICATION 5954S

is just below the pawl shaped surface on the upright projection of stop lever 164146 (Figure 7).

2.53 Lubricate the character generator mechanism as indicated on the attached figures, replace the keyboard hood, and finally the keyboard in accordance with standard practice.

End-Of-Message Code Drum Change (Figure 7)

2.54 Unhook drive link spring 90573 from eccentric stud 164169.

2.55 Disengage the slot in drive line 164160 from the stud on drive plate 164165.

2.56 Grasp the code drum with the thumb and first two fingers of the left hand. While pushing the entire assembly to the right, lift the drum and its drive plate out of the mechanism. Slide the drum assembly from the shaft of the drive plate and replace it with the one desired.

2.57 Depress the stepping pawl extension to raise the pawl so that the new drum bears against the hub on the drive plate and the pawl fully engages the projections on the code blades.

2.58 Hold the assembled parts as shown in Figure 7 and reinsert them in the character generator by reversing the disassembly instructions.

2.59 Hook spring 90573 on eccentric stud 164169.

2.60 Make certain that the slot in drive link 164160 engages the stud on the drive plate; if necessary, turn the drive plate with its attached stepping pawl held out of engagement with the code blades so that the parts are properly aligned.

2.61 If the codebar bail latch has been released during the above procedure, relatch stop lever 164146 on armature latch 164158 and turn the motor handwheel or signal generator shaft until the signal generator clutch is disengaged.

2.62 Turn the code drum clockwise until, in its fully dented position, the sensing levers are resting on stop blade 164163 which is just below the pawl shaped surface of the upright projection of stop lever 164146.

INSTALLATION PROCEDURES FOR MODIFICATION KIT 173122

2.63 For Installation instructions, see the following Paragraphs and Figures:

- (1) Paragraph 2.30 Figure 4
- (2) Paragraph 2.31 Figure 4
- (3) Paragraph 2.32 Figure 4

- (4) Paragraph 2.33 Figure 4
- (5) Paragraph 2.41 Figure 5
- (6) Paragraph 2.45 Figure 7
- (7) Paragraph 2.50

3. ADJUSTMENTS AND LUBRICATION

Note: For standard adjustments and lubrication procedures, refer to Teletype Model 28 Perforator Transmitter Bulletin 250B.

- 3.01 For modification kit 164502, make the following adjustments and refer to Figure 2 for lubrication.

3.02 KEYLEVER SWITCH HORIZONTAL

Requirement

With the contact assembly, guide, and code lever assembly lined up per Figure 2, there should be some 0.020 inch clearance (gauge by eye) between the right edge of the contact swinger insulator and the extension of the code lever assembly in the unoperated position.

To Adjust

Loosen screw 1178 holding the contact assembly to retainer bars 309510 and adjust. Tighten the screw.

3.03 KEYLEVER SWITCH VERTICAL

Requirement

With the unit in the stop position and the keylever depressed to a point where the clutch engages or the intended function is selected, the center and lower contact should just close or have a maximum gap of 0.008 inch.

To Adjust

Loosen two screws 156740 which fasten brackets 309508 and 309509 on two studs 121473 and position the complete mounting assembly.

- 3.04 For modification kit 173122, make the drive link adjustment shown in Figure 13.

4. THEORY OF OPERATION Modification Kit 164502 (Figures 1, 2, 5, and 7)

- 4.01 The end-of-message sequence is initiated from the keyboard by momentarily depressing the end-of-message (EOM) keylever assembly located in the 21st slot of the code lever guide. This closes a normally open contact assembly located beneath the keylever and locks the keyboard by means of a lever extension of the existing keyboard locking mechanism. The keylever becomes locked when the lockbar moves to the right. Normally open contacts (formerly used to electrically shunt the keyboard signal generator)

SPECIFICATION 5954S

are closed to complete an electrical circuit to the trip magnet of the character generator mechanism.

4.02 The application of voltage energizes the trip magnet and results in the counterclockwise rotation of the armature and associate stop lever latch unblocking and releasing the stop lever. Under the bias of a spring attached to the codebar bail latch operating lever, which rests on the left extension of the stop lever, the stop rotates counterclockwise until it comes to rest against the mechanism base plate. Before coming to rest, the stop lever moves the blocking lever counterclockwise blocking the drive plate and releasing it to its spring action. The drive plate rotates counterclockwise to a stop where the attached drive link is in a position to accept the feeding motion from the keyboard codebar bail. As the stop lever continues its counterclockwise rotation, the codebar bail latch rotates clockwise striking the codebar bail latch. The latch rotates clockwise and releases the codebar bail. The codebar bail releases the keyboard codebars and the clutch tripbar which move to the right under spring action. The clutch tripbar trips the signal generator clutch and/or perforator clutch, depending upon the position of the K-KT-T control switch, and initiates an operating cycle.

4.03 While the code combination transmitted and/or perforated during the first cycle must be a LETTERS combination, the code combinations of the succeeding 20 cycles may be any arbitrary character determined by the detachable code blades fastened to the code drum. The code combination on each blade is read by five sensing levers which transfer the code selections to a vertical projection on each of the five codebars. Each code combination is thus transmitted and/or perforated in the normal manner by the keyboard signal generator and/or perforator mechanism. A spacing condition occurs whenever a codebar is prevented from moving to the right by its associated sensing lever; unrestricted movement of a codebar results in a marking condition. Since the sensing levers must be held away from the codebars in order to prevent their interference during normal keyboard operation, a stop code blade having a LETTERS combination must be employed. This necessity results in a LETTERS combination for the first character.

4.04 Once during each rotation (360°) of the signal generator cam assembly, or half rotation (180°) of the perforator cam assembly, depending upon the position of the K-KT-T control switch, the codebar bail is pulled to the left by a cam eccentric causing it to rotate clockwise. The bail resets the keyboard codebars and, with the character generator drive link in its released position, rotates the drive plate clockwise. This action causes the stepping pawl to step the code drum one position clockwise.

4.05 With the stop lever in its released position, the codebar latch operating lever also maintains the codebar bail latch in a released position. The signal generator and/or perforator mechanism will cycle continuously until it rotates the code drum one full revolution or 21 characters. The first code blade, which is the stop code blade having a LETTERS combination, has an additional projection that when it is being rotated into the sensing position, it contacts the stop lever rotation it clockwise. The left extension of the stop lever rotates the codebar bail latch operating lever counterclockwise which releases

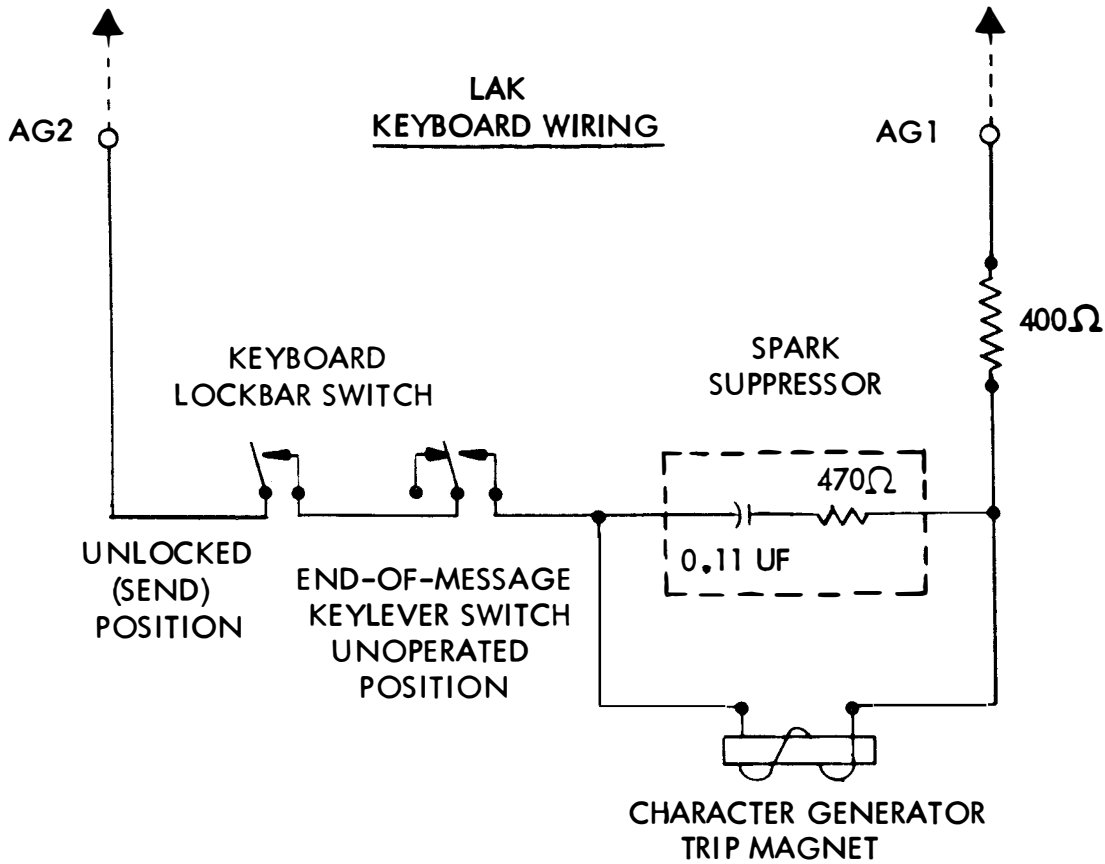
the codebar bail latch to the action of its attached spring. Continued rotation of the stop lever brings it in a position where, if released to the action of the spring attached to the codebar bail latch operating lever, it will reverse rotation and become latched on the stop lever latch attached to the trip magnet armature. Such a position is reached when the stop code blade passes its area of contact with the stop lever which is just prior to the complete movement of the stop code blade into the sensing position.

4.06 When the codebar bail latch is released to its spring action, it rotates counterclockwise in contact with the codebar bail latch roller until it latches the codebar bail. The blocking lever is also released to its spring action and it rotates counterclockwise until it rests against a projection on the stop lever. In this position the blocking lever holds the drive plate in its extreme clockwise position and the attached drive link is once more unable to follow the feeding motion from the codebar bail. Further operation of the signal generator and/or perforator mechanism and character generator is thus prevented. At this point the keyboard is restored to its normal operating condition except that it must be manually unlocked by depressing the SEND keylever before operation can be resumed.

4.07 The message of the character generator may be changed by replacing the entire code drum of the mechanism. See Paragraphs 2.01 through 2.09 for the necessary instructions.

TO 115 VOLTS AC
GROUNDED SIDE

TO 115 VOLTS AC
UNGROUNDDED SIDE



○ AG MOTOR TERMINAL BLOCK ON KEYBOARD (LAK)

----- EXISTING WIRES

———— WIRES FURNISHED IN MODIFICATION KIT 164502

REFER TO WIRING DIAGRAM 3459WD
FOR COMPLETE SCHEMATIC DIAGRAM

Figure 1 - Schematic Wiring Diagram of End-of-Message Character Generator

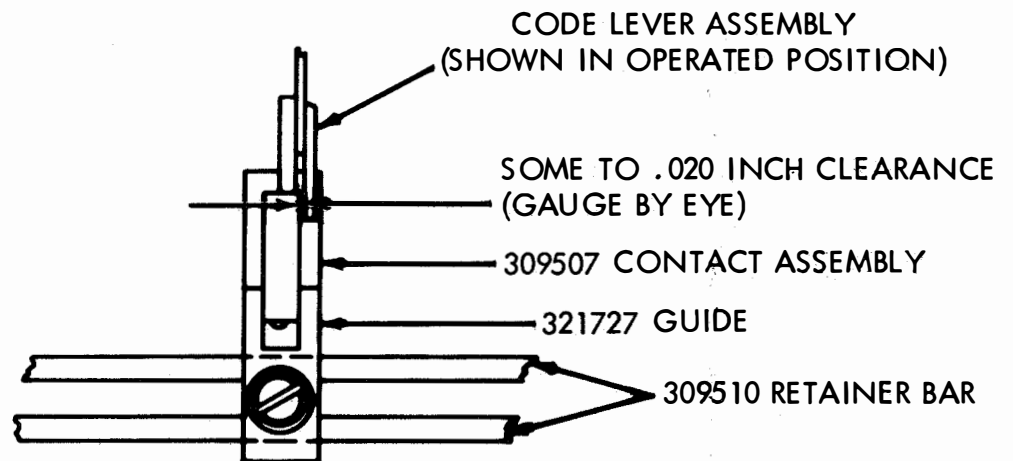
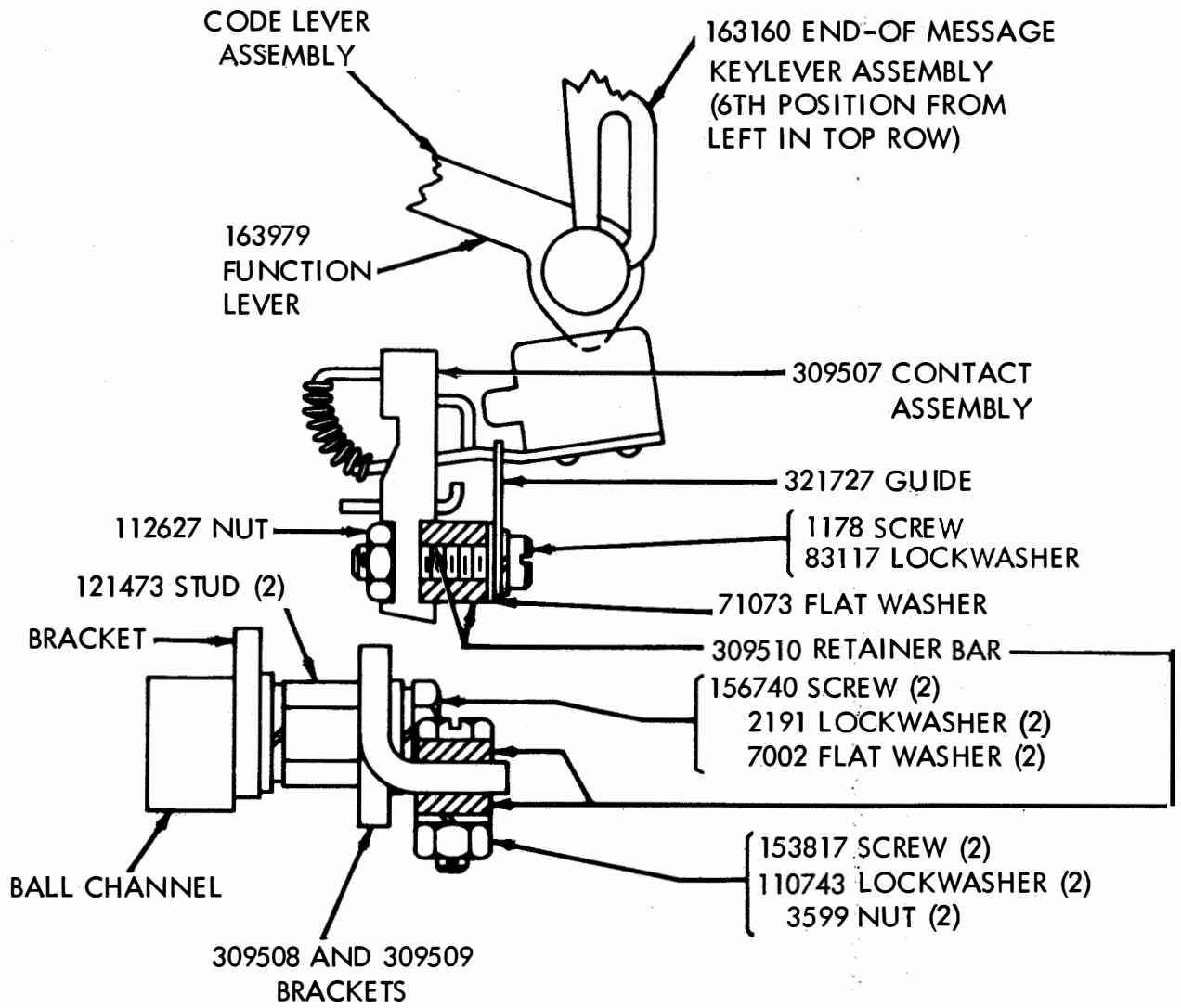
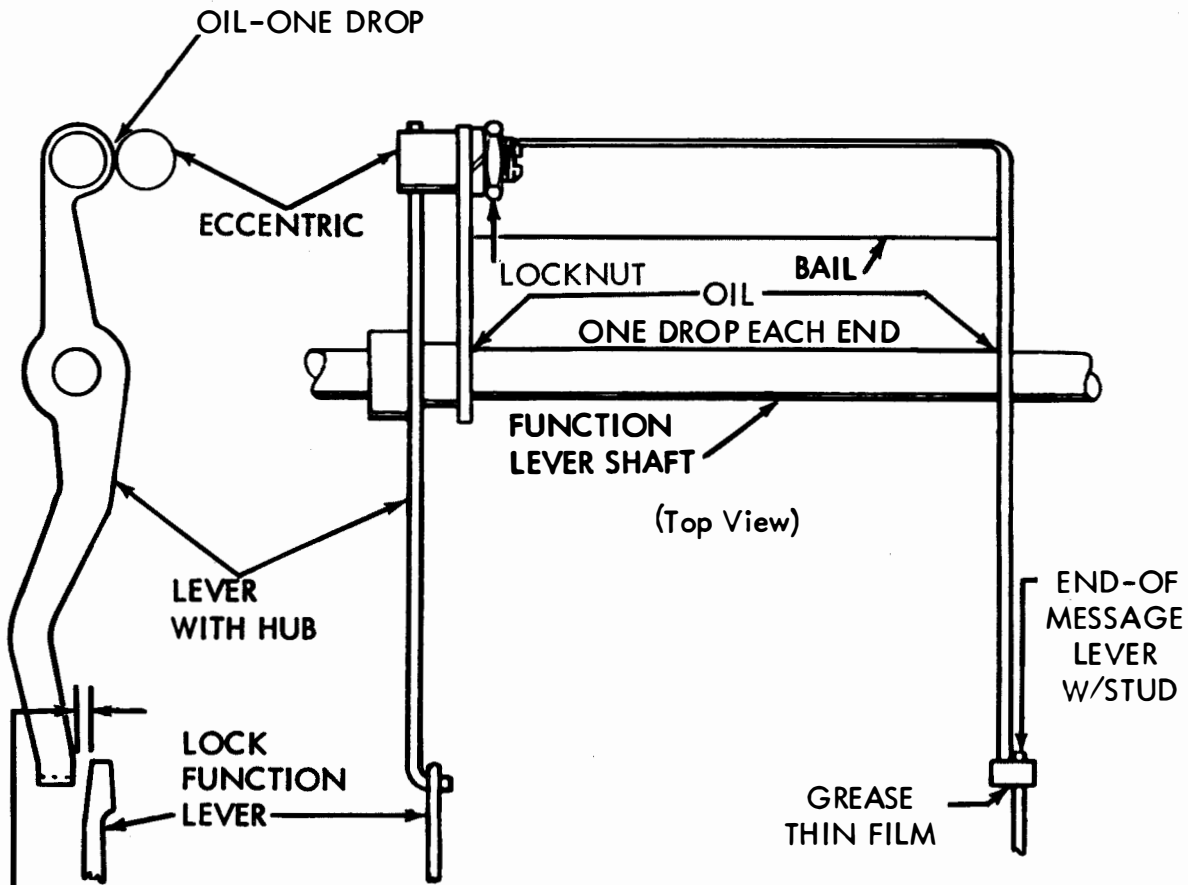


Figure 2



KEYBOARD LOCK BAIL ECCENTRIC

Requirement

Clearance between keyboard locklever w/hub and lock function lever should be

Min some --- Max 0.006 inch

To Check

Fully depress both REC and EOM keys (hold lightly).

To Adjust

Position the eccentric with its locknut loosened so that its high point is toward the front of the keyboard.

Figure 3

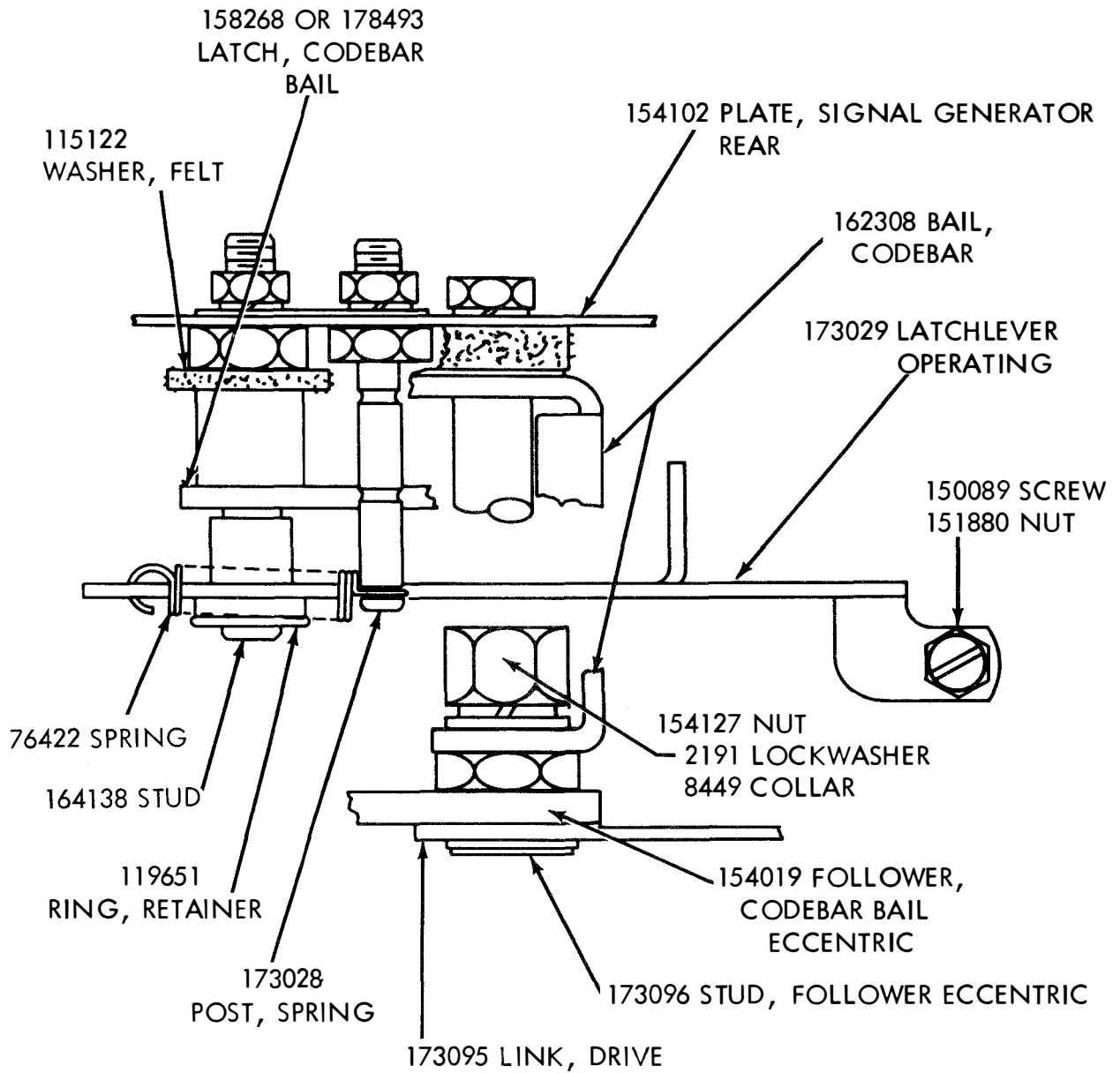


Figure 4

SPECIFICATION 5954S

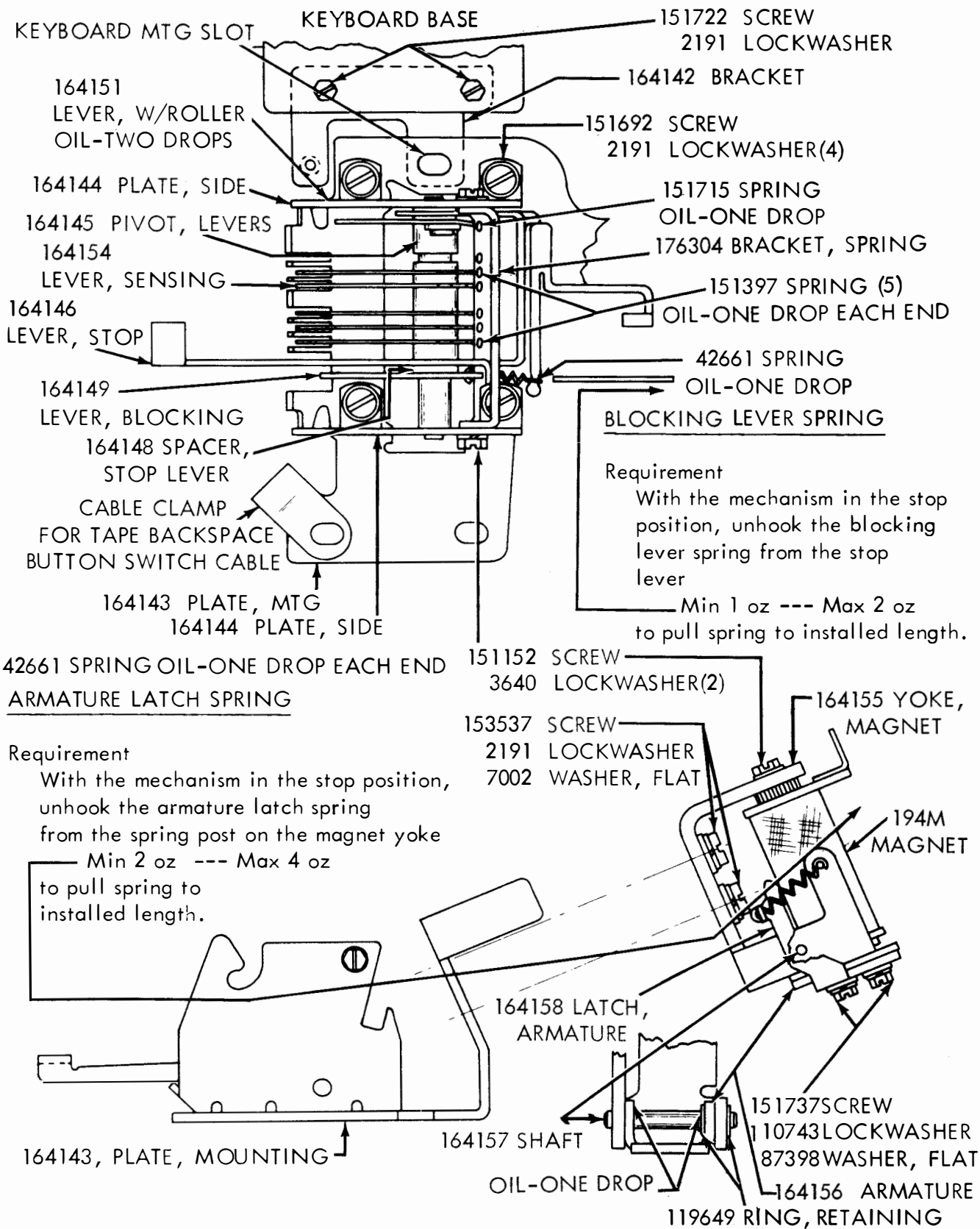
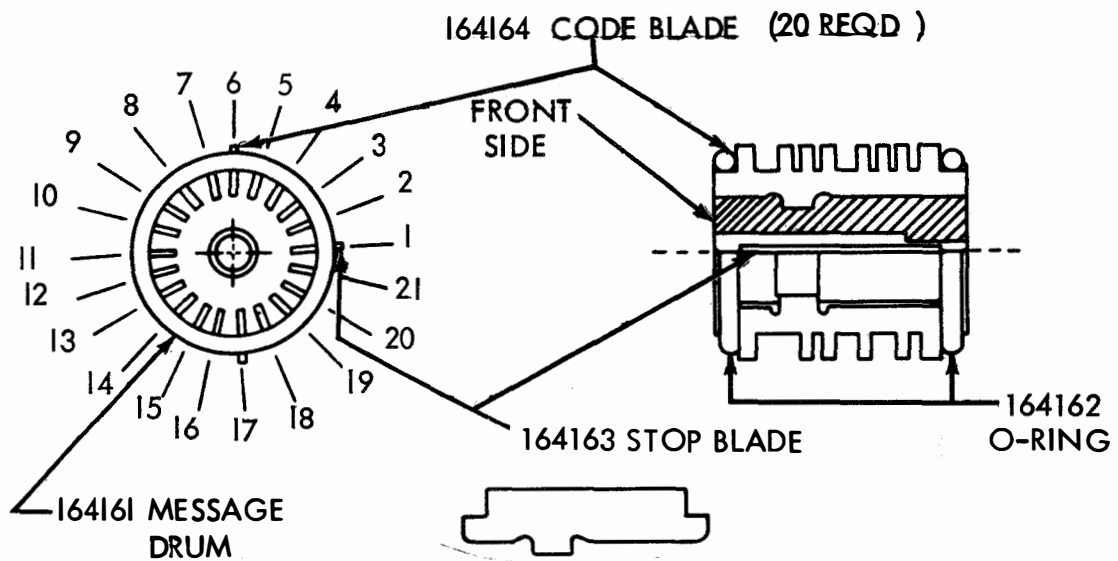


Figure 5



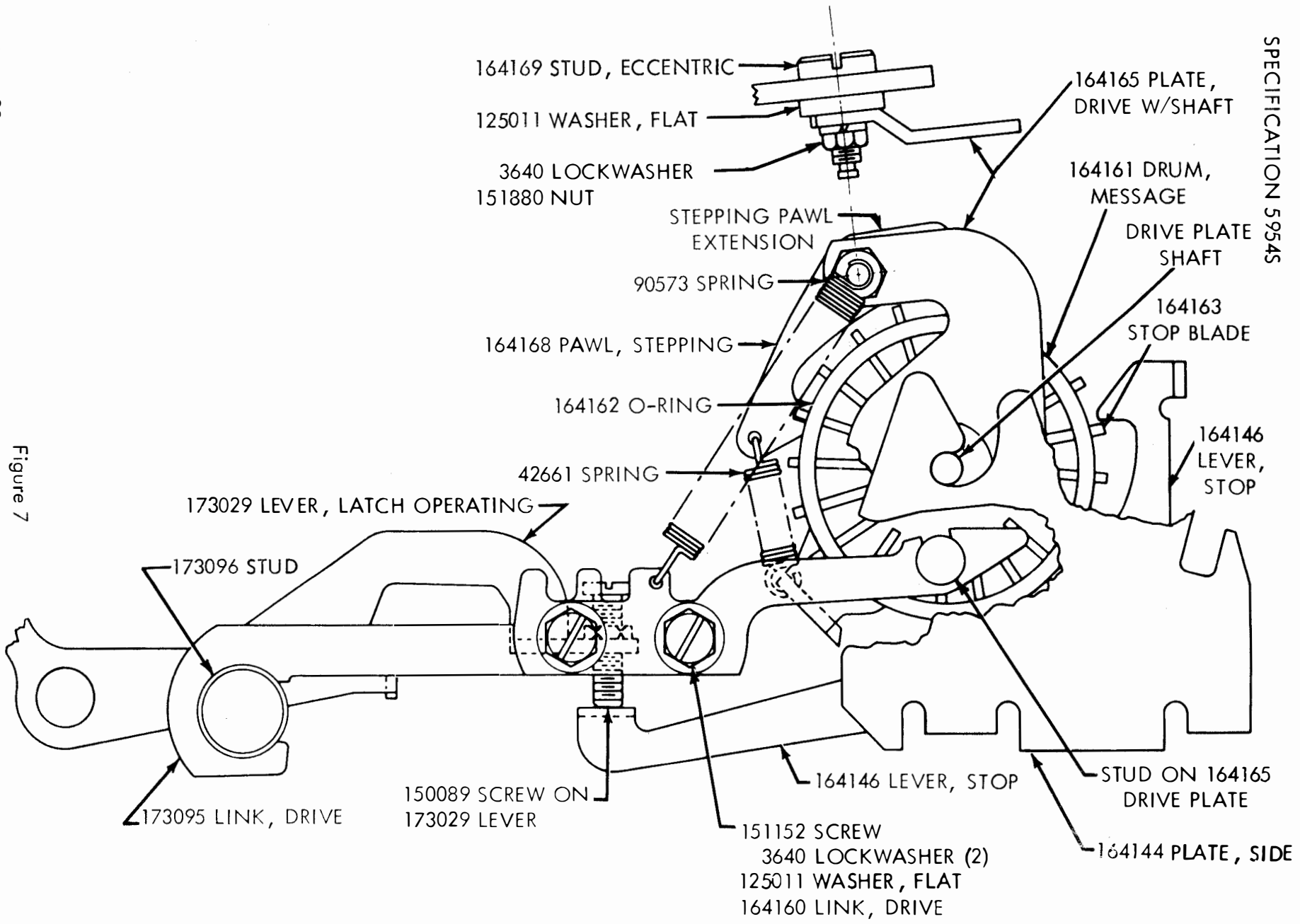
LETTERS	TYPICAL FIG. ARRGT.	CODE				
		1	2	3	4	5
A	—	■	■	■	■	■
B	2	■	■	■	■	■
C	:	■	■	■	■	■
D	\$	■	■	■	■	■
E	3	■	■	■	■	■
F	!	■	■	■	■	■
G	&	■	■	■	■	■
H	#	■	■	■	■	■
I	8	■	■	■	■	■
J	,	■	■	■	■	■
K	(■	■	■	■	■
L)	■	■	■	■	■
M	.	■	■	■	■	■
N	,	■	■	■	■	■
O	9	■	■	■	■	■
P	0	■	■	■	■	■
Q	!	■	■	■	■	■
R	4	■	■	■	■	■
S	BELL	■	■	■	■	■
T	5	■	■	■	■	■
U	7	■	■	■	■	■
V	;	■	■	■	■	■
W	2	■	■	■	■	■
X	/	■	■	■	■	■
Y	6	■	■	■	■	■
Z	"	■	■	■	■	■
CARRIAGE RETURN		■	■	■	■	■
LINE FEED		■	■	■	■	■
LETTERS SHIFT		■	■	■	■	■
FIGURES SHIFT		■	■	■	■	■
SPACE		■	■	■	■	■
BLANK		■	■	■	■	■

■ — LEAVE TINE
 □ — REMOVE TINE

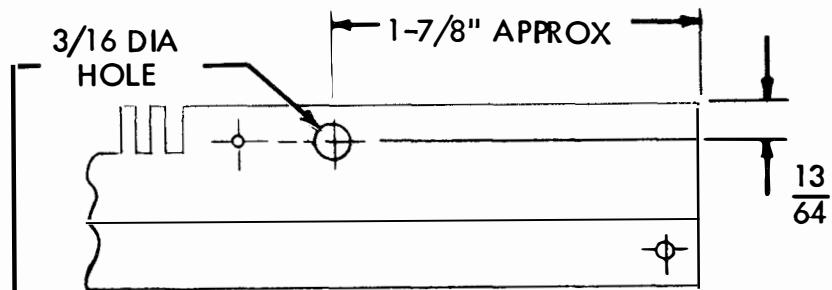
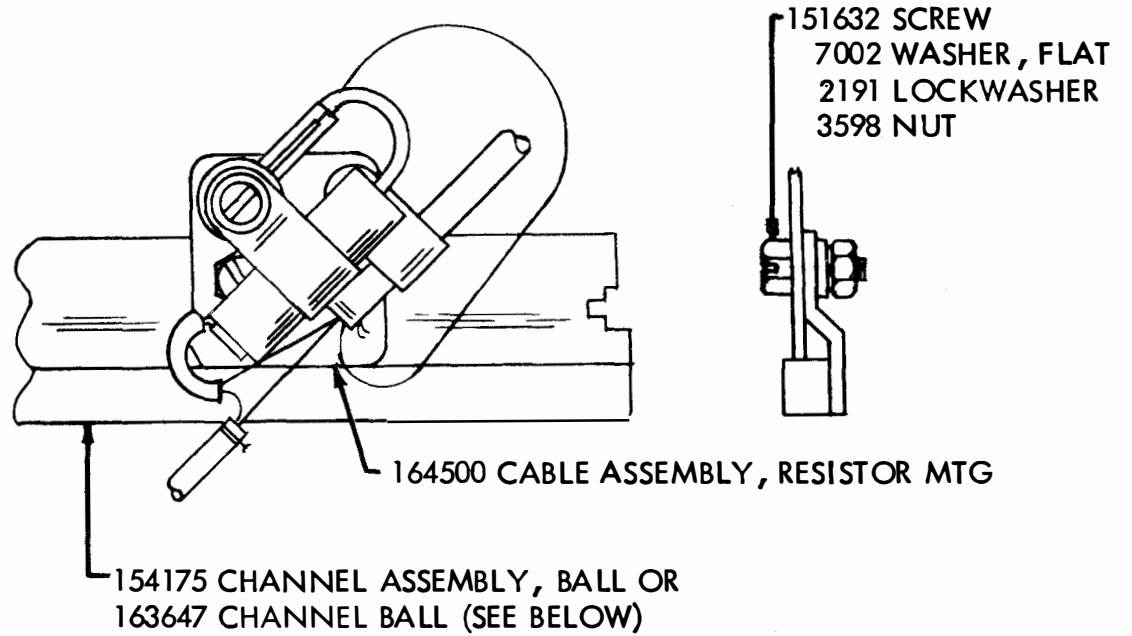


Figure 6

Figure 7



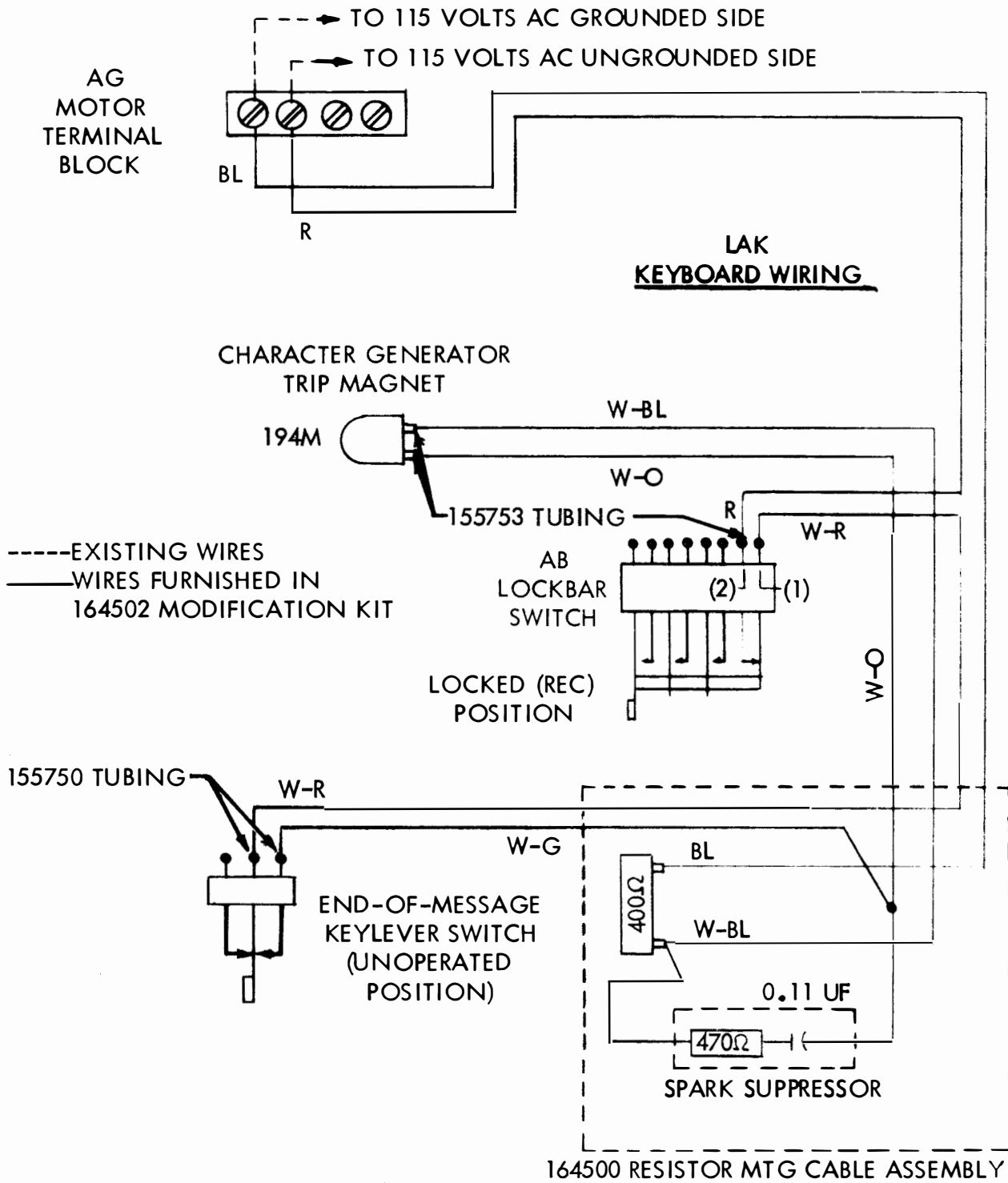
RIGHT SIDE OF CHANNEL



IF 163647 BALL CHANNEL DOES NOT HAVE 3/16 DIAMETER HOLE (EARLY VERSION) THIS CAN BE ADDED AS SHOWN HERE.

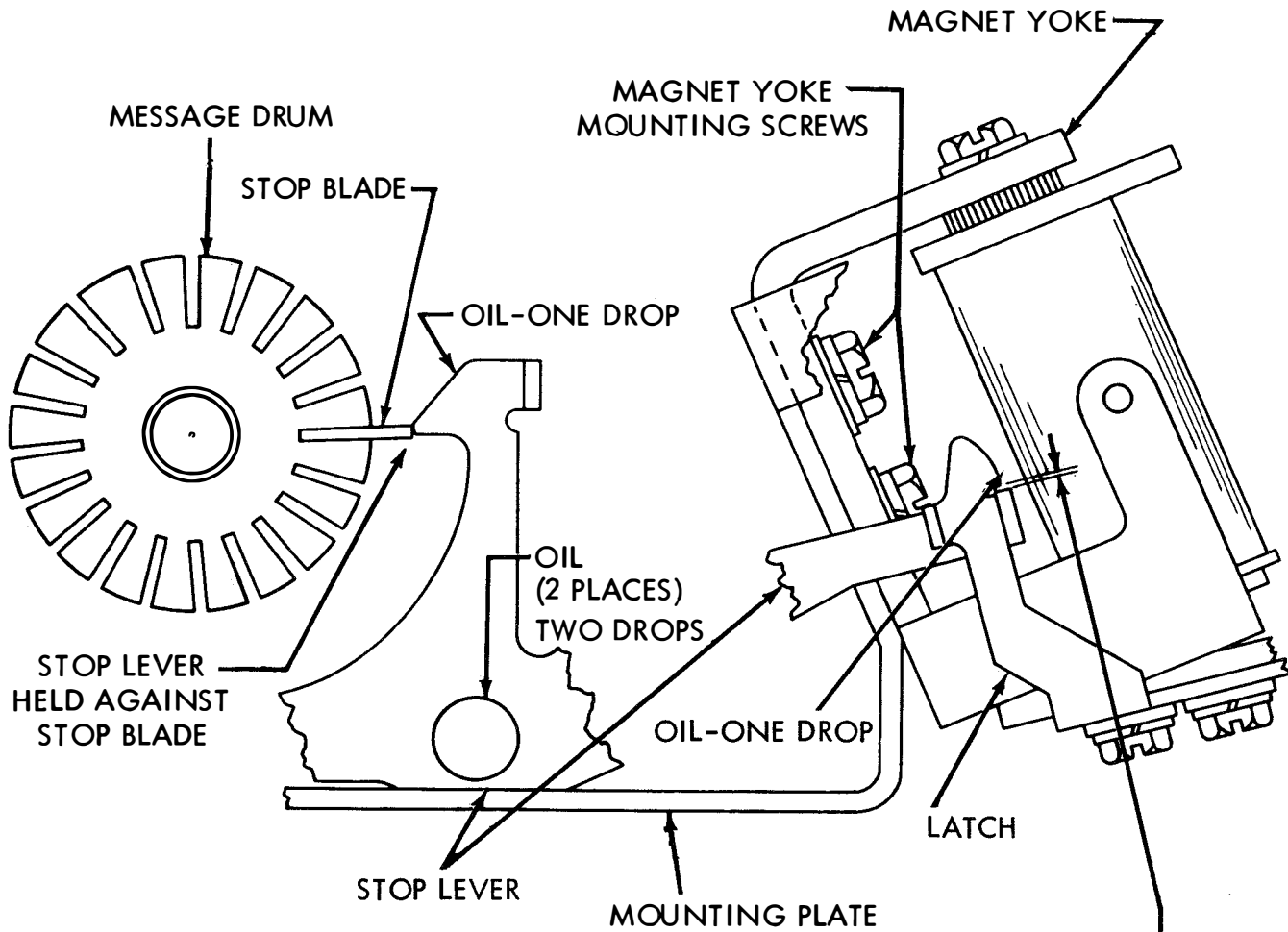
Figure 8

SPECIFICATION 5954S



REFER TO WIRING DIAGRAM 3458WD FOR COMPLETE ACTUAL DIAGRAM.

Figure 9 - Actual Wiring Diagram of End-of-Message Character Generator



MAGNET YOKE

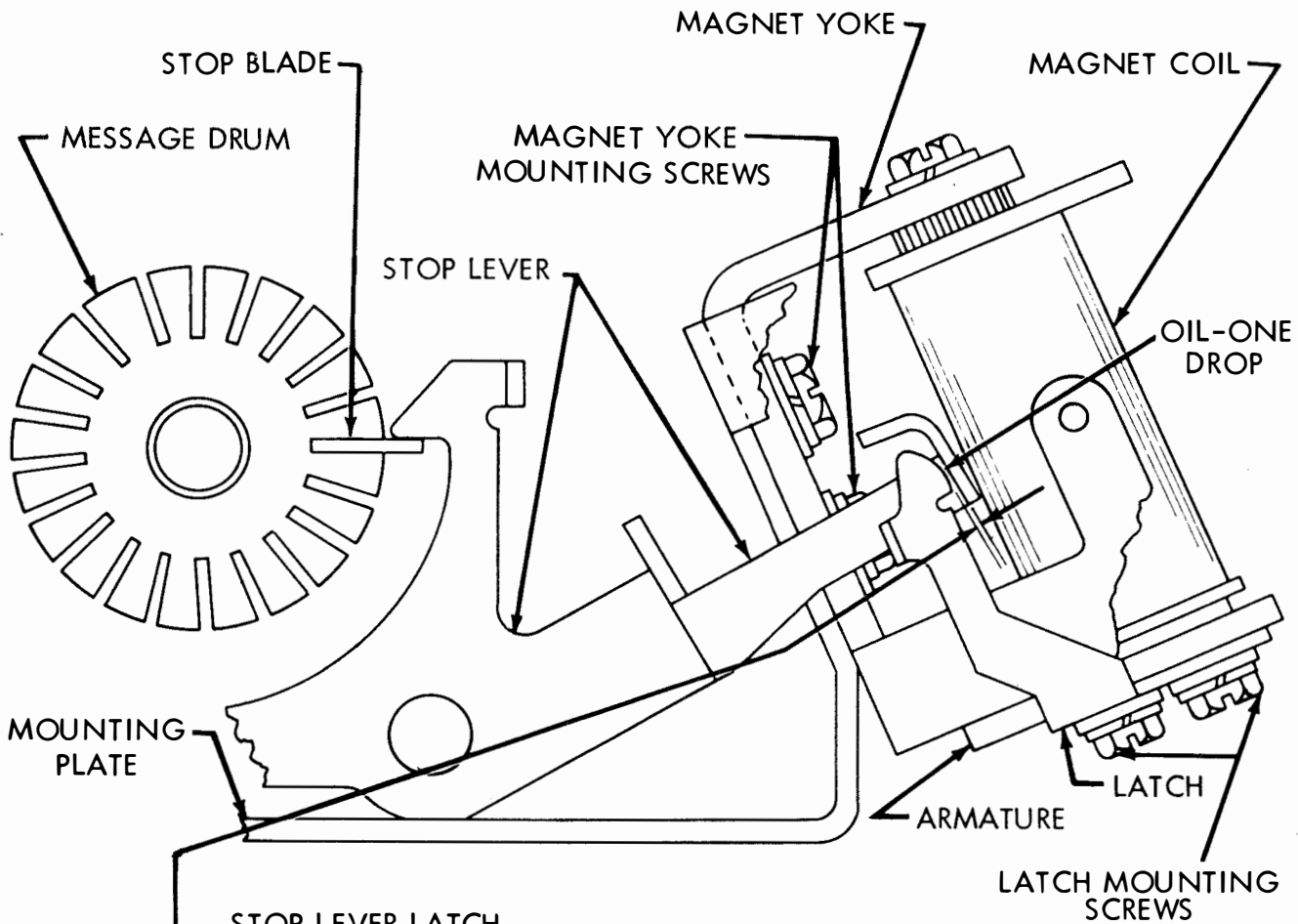
Requirement

With the tip of the stop lever held against the stop blade, there should be from 0.005 inch to 0.015 inch clearance on the stop lever extension and its latch.

To Adjust

Rotate the message drum to meet the requirement and then position the magnet yoke by means of its two mounting screws.

Figure 10



STOP LEVER LATCH

Requirement

With the armature held against the magnet core and the stop lever held in its extreme counterclockwise position, there should be 0.002 inch to 0.007 inch clearance between the stop lever and its latch. There should also be a minimum of 0.002 inch clearance between the stop lever and its latch throughout the complete travel of the stop lever.

To Adjust

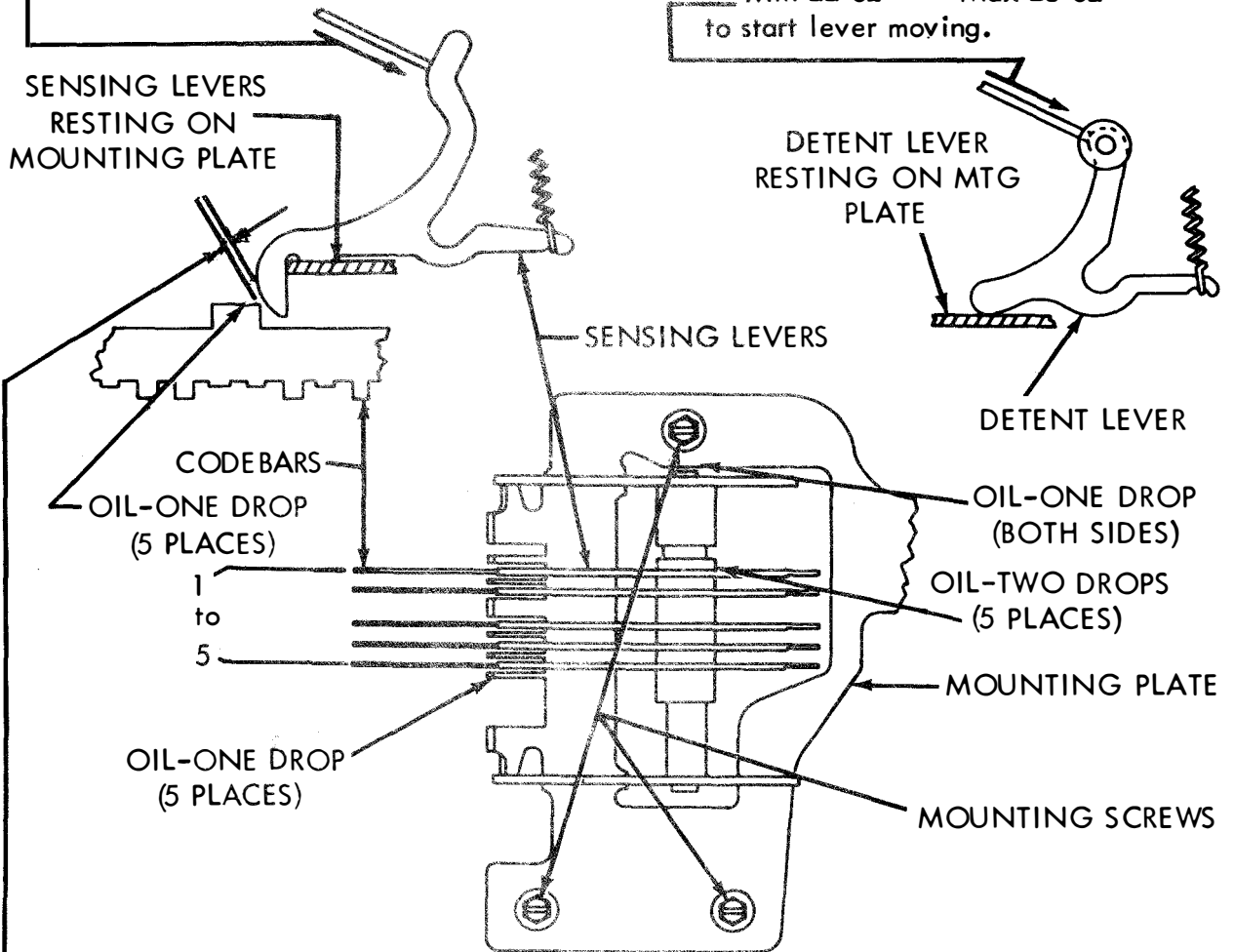
Position the latch by means of its two mounting screws.

Figure 11

SENSING LEVER SPRINGS

Requirement

With the mechanism in stop position and the message drum removed
 Min 1/4 oz --- Max 1-1/4 oz
 to start each lever moving.



DETENT LEVER SPRING

Requirement

With the mechanism in stop position, the drum removed
 Min 22 oz --- Max 26 oz
 to start lever moving.

CHARACTER GENERATOR MOUNTING PLATE

Requirement

With signal generator clutch disengaged, sensing levers should be centrally located on codebars, so that each lever rests on the full width of its associated codebar. Clearance between shoulders of codebars Number 1 and Number 5 and their associated sensing levers should be
 Min 0.002 inch --- Max 0.012 inch

To Adjust

Position the mounting plate with the three mounting screws loosened. This adjustment is facilitated by removing the message drum and drive plate assembly from the mechanism.

Figure 12

DRIVE LINK SPRING

Requirement

With mechanism in stop position,
Min 10 oz --- Max 15 oz
to pull spring to
installed length.

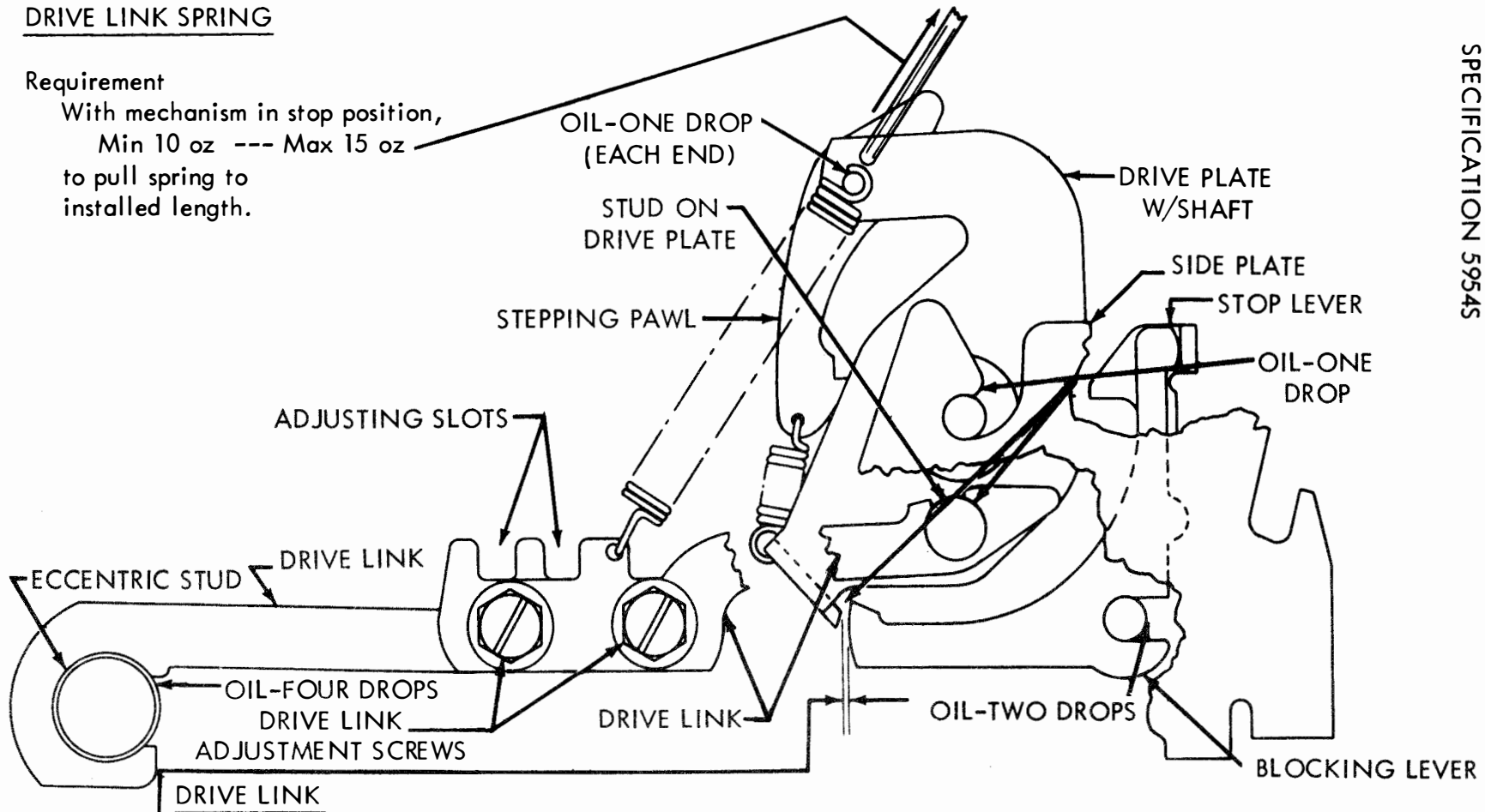


Figure 13

Requirement

With keyboard switch in T position and perforator reset lever holding codebar bail in extreme reset position to the left, there should be Min some --- Max 0.007 inch clearance between the drive plate extension and the blocking lever. The some requirement shall be considered met if the blocking lever can be rotated through its operating arc without touching the drive plate extension.

Note: On 2 cycle perforator units make this check from both perforator cam lobes.

To Adjust

Position the two drive links relative to each other by means of the adjusting slots and screws.

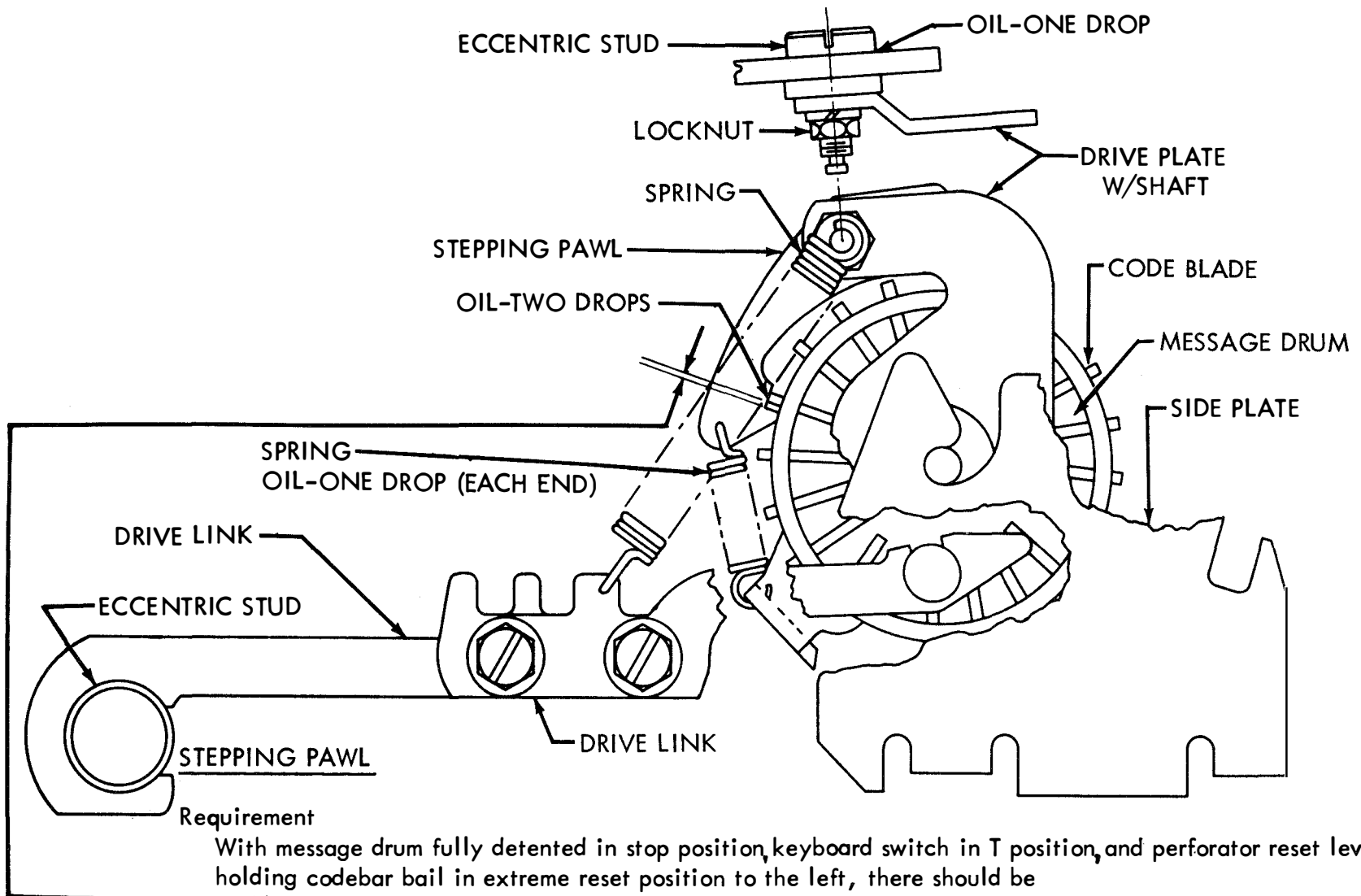


Figure 14

Requirement

With message drum fully detented in stop position, keyboard switch in T position, and perforator reset lever holding codebar bail in extreme reset position to the left, there should be
 Min 0.020 inch --- Max 0.030 inch
 clearance between the stepping pawl and its adjacent code blade.

Note: On 2 cycle perforator units make this check from both perforator cam lobes.

To Adjust

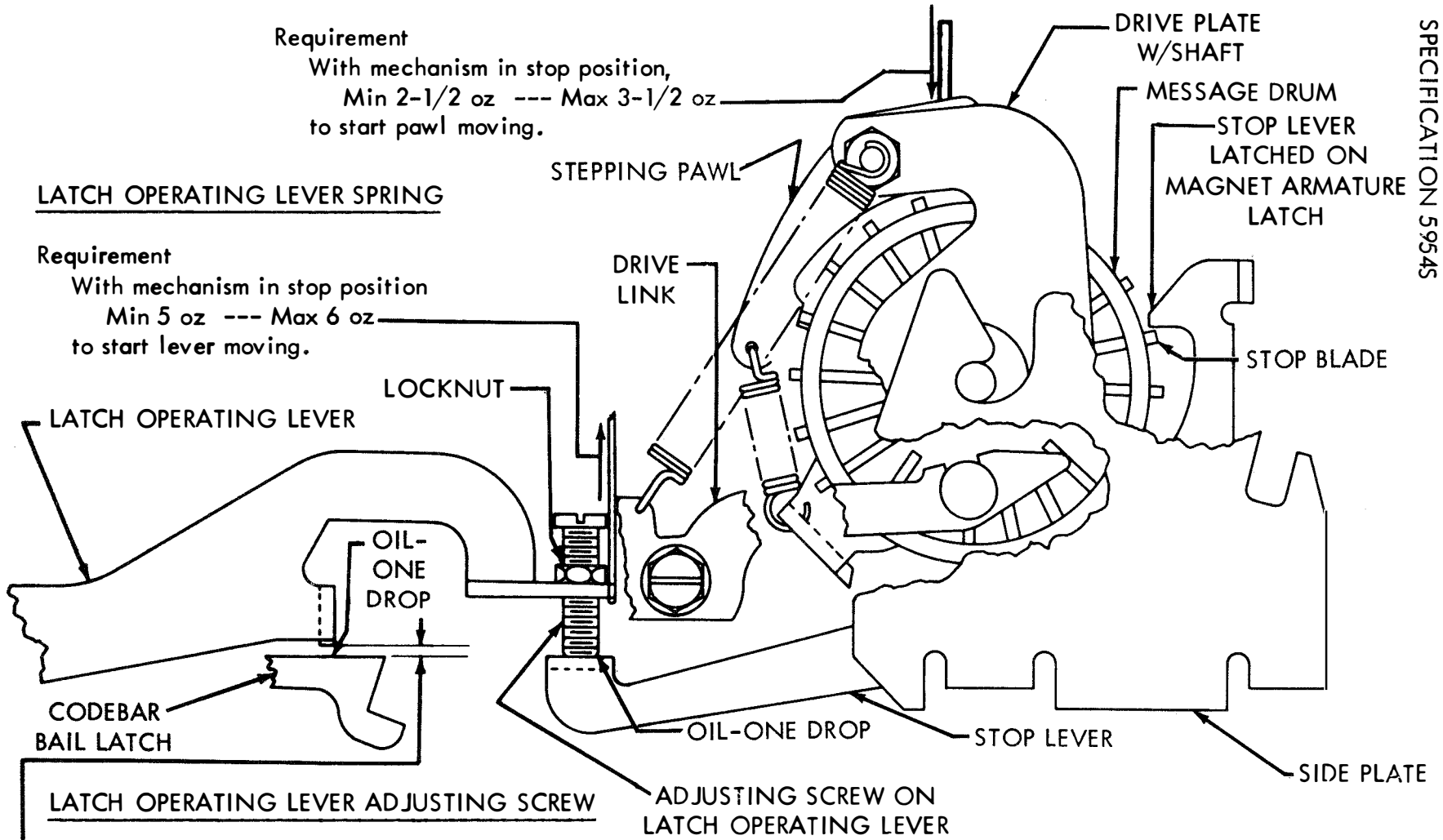
Position the eccentric stud with its lock nut loosened so that its high point is toward the top.

STEPPING PAWL SPRING

Requirement
 With mechanism in stop position,
 Min 2-1/2 oz --- Max 3-1/2 oz
 to start pawl moving.

LATCH OPERATING LEVER SPRING

Requirement
 With mechanism in stop position
 Min 5 oz --- Max 6 oz
 to start lever moving.



SPECIFICATION 5954S

LATCH OPERATING LEVER ADJUSTING SCREW

Requirement
 With stop lever latch on magnet armature latch and signal generator clutch fully disengaged, there should be Min 0.005 inch --- Max 0.015 inch clearance between the extension on the latch operating lever and the codebar bail latch.

To Adjust
 Position the latch operating adjusting screw with its locknut loosened.

Figure 15