

14 TELETYPEWRITER (AUXILIARY FEATURES)

REQUIREMENTS AND ADJUSTMENTS

CONTENTS	PAGE	CONTENTS	PAGE
1. GENERAL .....	2	Carriage shift-plate .....	12
2. BELL AND BREAK SIGNAL MECHANISM (TP77222) .....	2	FIGS locking pawl .....	10
Bell hammer .....	2	FIGS locking pawl spring .....	14
Contact arm .....	2	FIGS stop-screw .....	10
Contact springs .....	2	Shift-plate eccentric .....	12
Detent-arm spring .....	2	7. POSITIVE CARRIAGE SHIFT (NEW STYLE) (TP83969) .....	14
3. MECHANICAL END-OF-LINE INDICATOR (TP89960) .....	3	Carriage capstan nuts .....	14
Cam-lever spring .....	5	Carriage locking-toe .....	14
Contact bracket .....	5	Carriage shift-plate .....	14
Feed-pawl spring .....	5	FIGS locking pawl .....	14
Lamp-contact springs .....	3	FIGS locking pawl spring .....	15
Release-bail spring .....	5	FIGS stop-screw .....	14
Worm-follower release bail .....	5	Shift-plate eccentric .....	14
Worm-follower spring .....	5	8. PULLBAR-CONTACT MECHANISM (TP97125 and TP97140) .....	15
Worm-shaft .....	3	Pullbar-contact assembly .....	16
Worm-shaft spring .....	3	Pullbar-contact mounting-plate ..	15
4. NONPRINTING AND NONSPACING ON LOWER-CASE BLANK WITH PRINTING AND SPACING ON UPPER-CASE BLANK (TP84641) ...	5	Pullbar guard .....	16
Space suppression lever stop-arm.	5	9. PUSH TAPE-FEED MECHANISM (TP87374) .....	18
Space suppression lever (rear edge)	7	Carriage locking-toe .....	19
Space suppression lever (end) .....	7	Center tape guide .....	19
Spacer locking-bail spring .....	5	Right tape guide .....	19
5. PLATEN-SHIFT CONTACTS MECHANISM (TP99342 and TP99343) .	7	Tape feed roll spring tension ....	19
Contact operating lever .....	8	10. REMOTE SIGNAL BELL (OLD) (TP88894) .....	19
Platen-shift contact assembly (FIGS make type) .....	10	Remote signal bell contacts .....	19
Platen-shift contact assembly (LTRS make type) .....	8	11. REMOTE SIGNAL BELL (NEW) (TP104479) .....	21
6. POSITIVE CARRIAGE SHIFT (OLD STYLE) (TP83969) .....	10	Remote signal bell contacts .....	21
Carriage capstan nuts .....	12	12. UNIVERSAL CONTACT MECHANISM (OLD STYLE MAKE) (TP99344) ....	21
Carriage locking-toe .....	10	Contact operating-lever .....	21
		Universal contact assembly .....	22

CONTENTS	PAGE
13. UNIVERSAL CONTACT MECHANISM (NEW STYLE MAKE) (TP104471)...	22
Contact operating-lever .....	23
Universal contact assembly .....	23
14. UNIVERSAL CONTACT MECHANISM (TRANSFER TYPE) (TP104682) ....	24
Contact operating-lever .....	24
Universal contact assembly .....	24

## 1. GENERAL

1.01 This section covers the requirements and adjustments of the auxiliary features for the 14 teletypewriter. An auxiliary feature is an apparatus assembly which is not regularly a part of coded machines but is ordered separately to be installed on new machines before delivery, or by telephone companies on the machines which they have. In a few instances, coded machines include an auxiliary feature, but this is the exception rather than the rule.

1.02 This section is reissued to revise the adjusting procedures for the push tape-feed mechanism and to otherwise bring the section up to date. Because of the number of changes involved, marginal arrows have been omitted.

1.03 Where possible, the requirements and adjustments are shown on the figures, thus reducing the text material.

## 2. BELL AND BREAK SIGNAL MECHANISM

Note: This set of parts (TP77222) allows a station which is receiving to break transmission from the opposite end and, by means of a bell, notify the distant attendant of the break.

2.01 Detent-arm Spring: It should require minimum 18 ounces, maximum 22 ounces to pull the spring to position length with the finger arm against the upper stop. (See Figure 1.)

2.02 Bell Hammer: The bell hammer should clear the bell by approximately 0.010 inch when the finger arm is against the lower stop. (See Figure 2.)

To Adjust: Bend the bell-hammer wire.

2.03 Contact Arm: The contact arm should clear the ends of the contact guards by approximately 0.020 inch when play in the contact arm is taken up in a direction to make this clearance a minimum. (See Figure 2.)

To Adjust: Position contact mounting screws.

2.04 Contact Springs: For units equipped with a single contact (break) or with two contacts (make and break), the following requirements should be met:

### (1) Single Contact:

(a) Clearance between the contacts should be minimum 0.015 inch, maximum 0.020 inch with finger arm against the upper stop. (See Figure 1.)

To Adjust: Bend the upper contact spring.

(b) Contacts should be closed with a pressure of minimum 3 ounces, maximum 4 ounces measured at a point just in front of the contact arm and with the finger arm against the lower stop. (See Figure 2.)

To Adjust: Bend the lower contact spring.

### (2) Double Contacts:

(a) Clearance between the contacts should be minimum 0.015 inch, maximum 0.020 inch with the finger arm against the upper stop. (See Figure 1.)

To Adjust: Bend the upper contact spring.

(b) Contacts should be closed with a pressure of minimum 3 ounces, maximum 4 ounces measured at a point just in front of the contact arm and with the finger arm against the lower stop. (See Figure 2.)

To Adjust: Bend the lower contact spring.

Note: The break contacts in (a) and (b) immediately above are mounted on the left side of the slip-connection guard-plate.

(c) Make contacts (mounted on the right side of the slip-connection guard-plate) should be closed with a pressure of minimum 4-1/2 ounces, maximum 6 ounces measured at the contact points and with the finger arm resting against the upper stop. See Figure 1 for identification of parts.

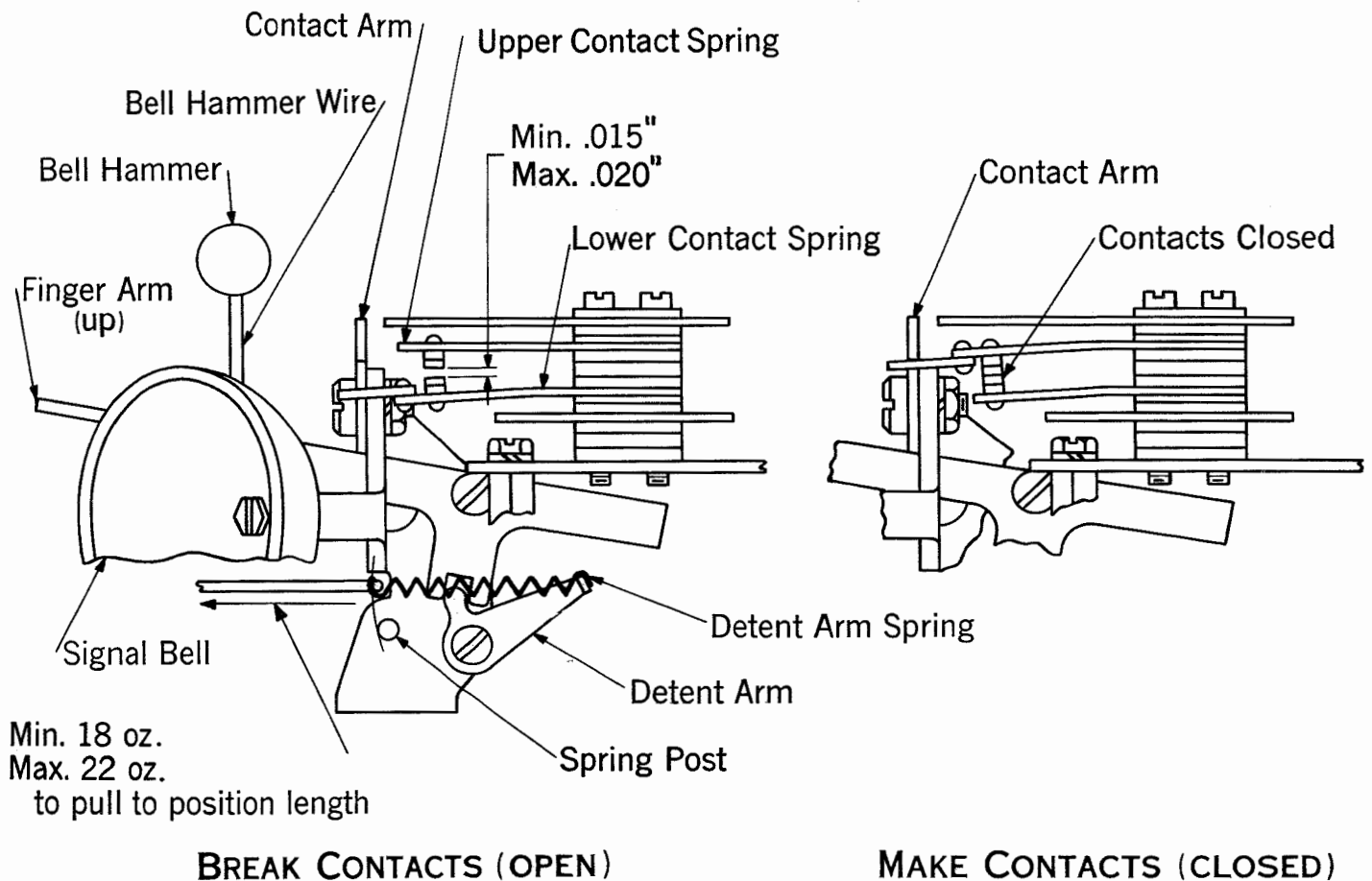

Figure 1

To Adjust: Bend the upper contact spring.

(d) The clearance between the make contacts should be minimum 0.015 inch, maximum 0.020 inch with the finger arm resting against the lower stop. (See Figure 2.)

To Adjust: Bend the lower contact spring.

### 3. MECHANICAL END-OF-LINE INDICATOR

Note: This set of parts (TP89960) provides visual indication, on a tape typing unit, that a full line for a page printer has been transmitted and that a CAR RET character must be sent.

3.01 Worm Shaft: The worm shaft should be free to rotate, with a minimum amount of end-play, when the worm-shaft spring is detached from the contact bracket. (See Figure 3.)

To Adjust: Position the worm-shaft collar by means of the set screws.

3.02 Worm-shaft Spring: The worm-shaft spring should have sufficient drag to prevent backlash of the worm-shaft.

### 3.03 Lamp-contact Springs:

(a) The front lamp-contact spring should press against its stiffener with a pressure of minimum 3 ounces, maximum 4 ounces. (See Figure 3.)

To Gauge: Using an 8-ounce scale, push perpendicular to the spring at the contact point when the contacts are in the unoperated position.

To Adjust: Remove the spring from the pile-up and bend it.

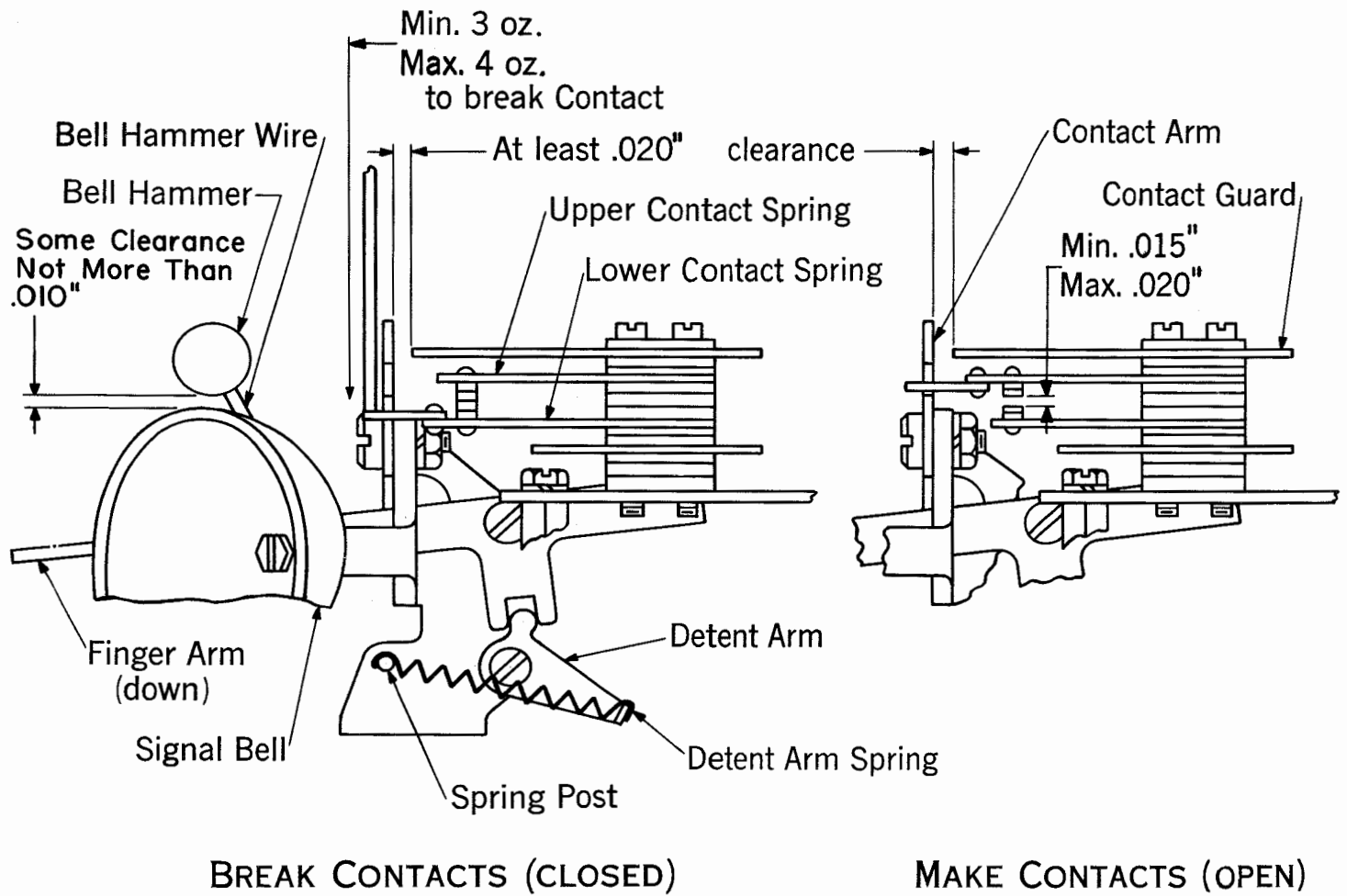

Figure 2

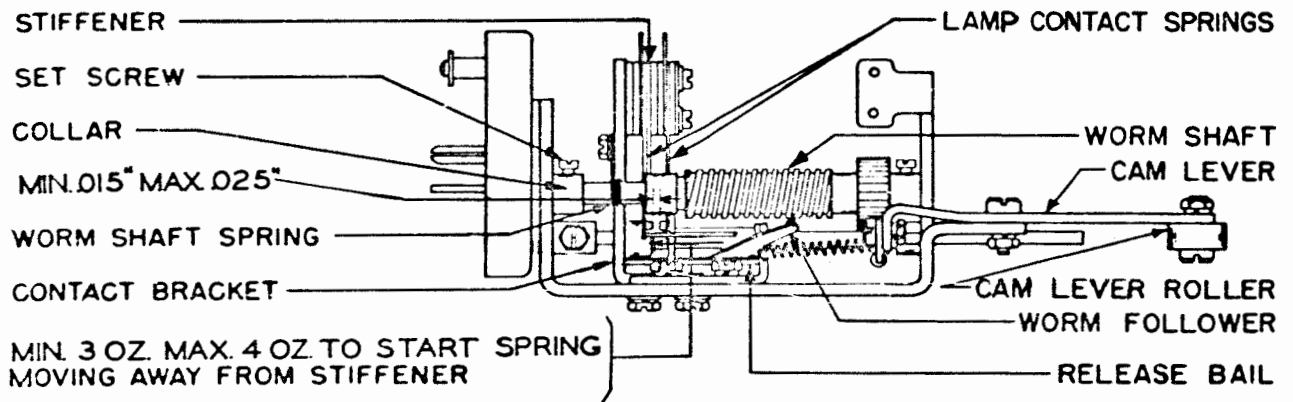

Figure 3

(b) With the front contact spring in the unoperated position, there should be minimum 0.015 inch, maximum 0.025 inch clearance between the front and rear contacts. (See Figure 3.)

To Adjust: Bend the rear spring.

3.04 Contact Bracket: The front lamp-contact spring should clear the lower edge of its stiffener by not more than 0.010 inch with the lamp contacts closed and the worm follower resting in the groove at the front of the worm. (See Figure 4.)

To Adjust: Position the contact bracket.

3.05 Worm-follower Release Bail: The bail should have perceptible end-play and should close the lamp contacts when minimum 62, maximum 66 characters have been received.

To Adjust: (Old arrangement) Position the contact bracket. (New arrangement) Position the collar on the ribbon reverse shaft and the contact bracket. Recheck the contact bracket adjustment.

3.06 Worm-follower Spring: The spring should have a tension of minimum 1-1/2 ounces, maximum 3-1/2 ounces at a point where the worm follower just touches the rear contact spring insulator. (See Figure 5.)

To Gauge: Hook the pull-end of an 8-ounce scale over the end of the worm-follower and pull parallel to the spring, holding the release bail so that the follower-pin clears the worm.

3.07 Release Bail Spring: It should require a tension of minimum 7 ounces, maximum

11 ounces to start the release bail moving from its unoperated position. (See Figure 6.)

To Gauge: Hook the pull-end of a 32-ounce scale under the edge of the release bail near the spring hole and pull vertically upward.

3.08 Feed-pawl Spring: It should require minimum 3 ounces, maximum 5-1/2 ounces to start the feed-pawl moving. (See Figure 7.)

To Gauge: Hook the pull-end of an 8-ounce scale around the feed-pawl at the spring hole and pull in line with the spring, keeping the cam-lever roller on the low part of its cam.

3.09 Cam-lever Spring: It should require minimum 28 ounces, maximum 38 ounces to move the cam lever. (See Figure 8.)

To Gauge: Hook the pull-end of a 64-ounce scale under the cam lever at the spring hole and pull in line with the spring, keeping the cam-lever roller on the low part of its cam.

4. NONPRINTING AND NONSPACING ON LOWER-CASE BLANK WITH PRINTING AND SPACING ON UPPER-CASE BLANK (TP84641)

Note: This set of parts allows spacing and typing on upper case BLANK combination and also includes a TP84634 type bar (with hyphen pallet).

4.01 Spacer Locking-bail Spring: The spring should have a tension of minimum 7-1/2 ounces, maximum 8-1/2 ounces when pulled vertically upward to position length.

4.02 Space Suppression Lever Stop-arm: (See Figure 9.)

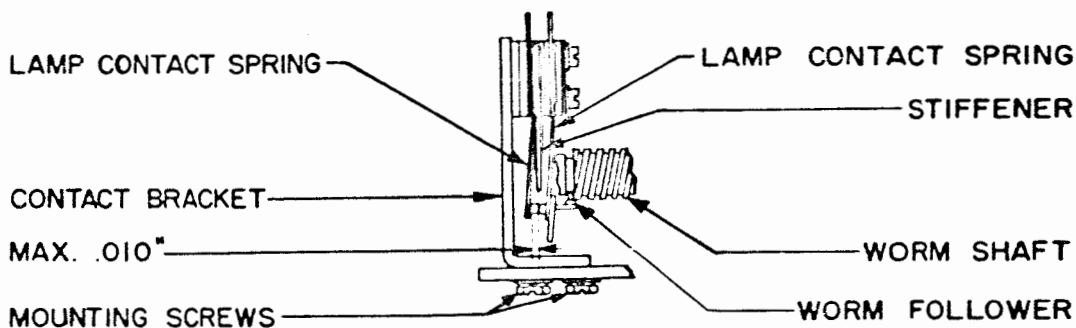

Figure 4

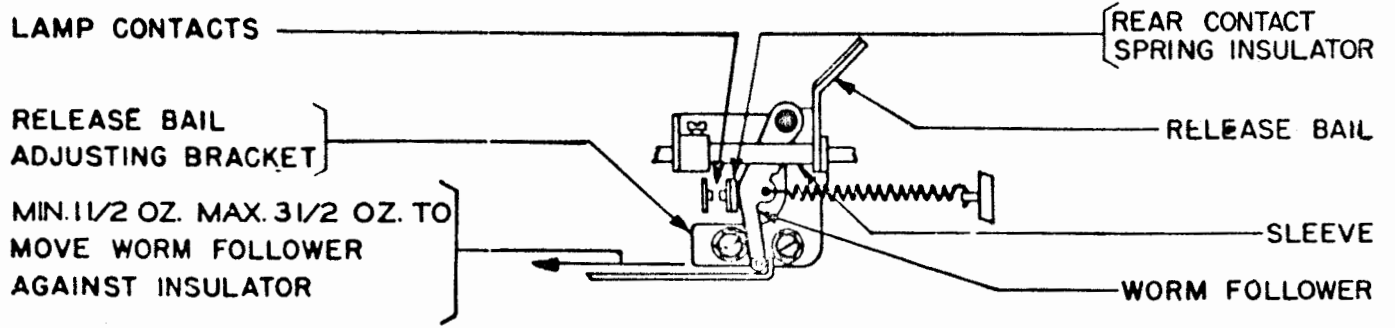

Figure 5

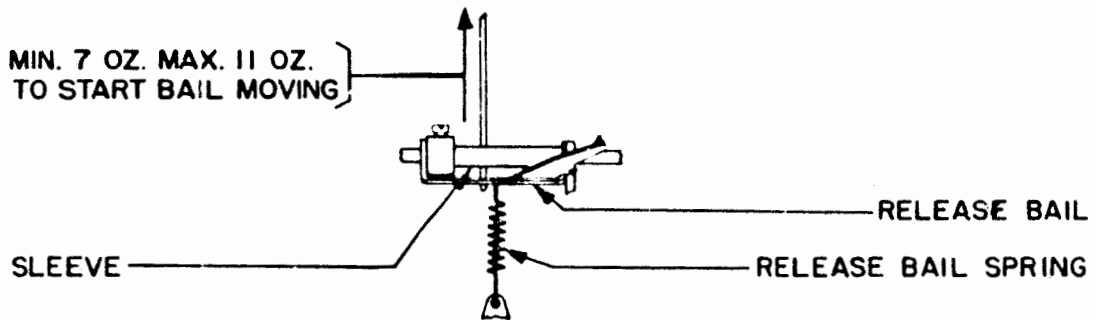

Figure 6

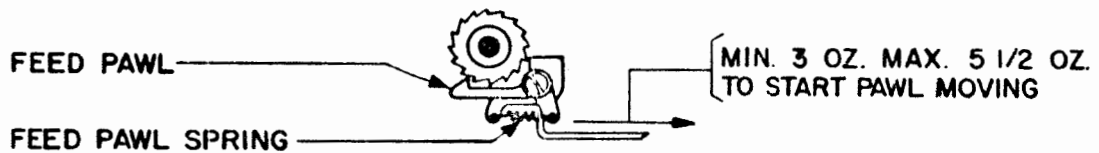

Figure 7

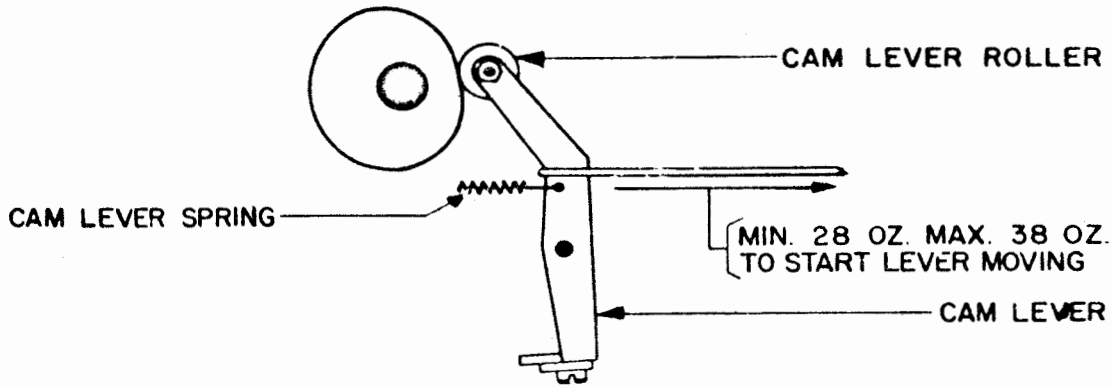

Figure 8

- 4.03 Space Suppression Lever Clearance (Rear Edge): (See Figure 10.)
- 4.04 Space Suppression Lever Clearance (End): (See Figure 11.)

5. PLATEN-SHIFT CONTACTS MECHANISM

Note: (LTRS Make, TP99342; FIGS Make, TP99343). This mechanism, designed to operate off the movement of the platen, is

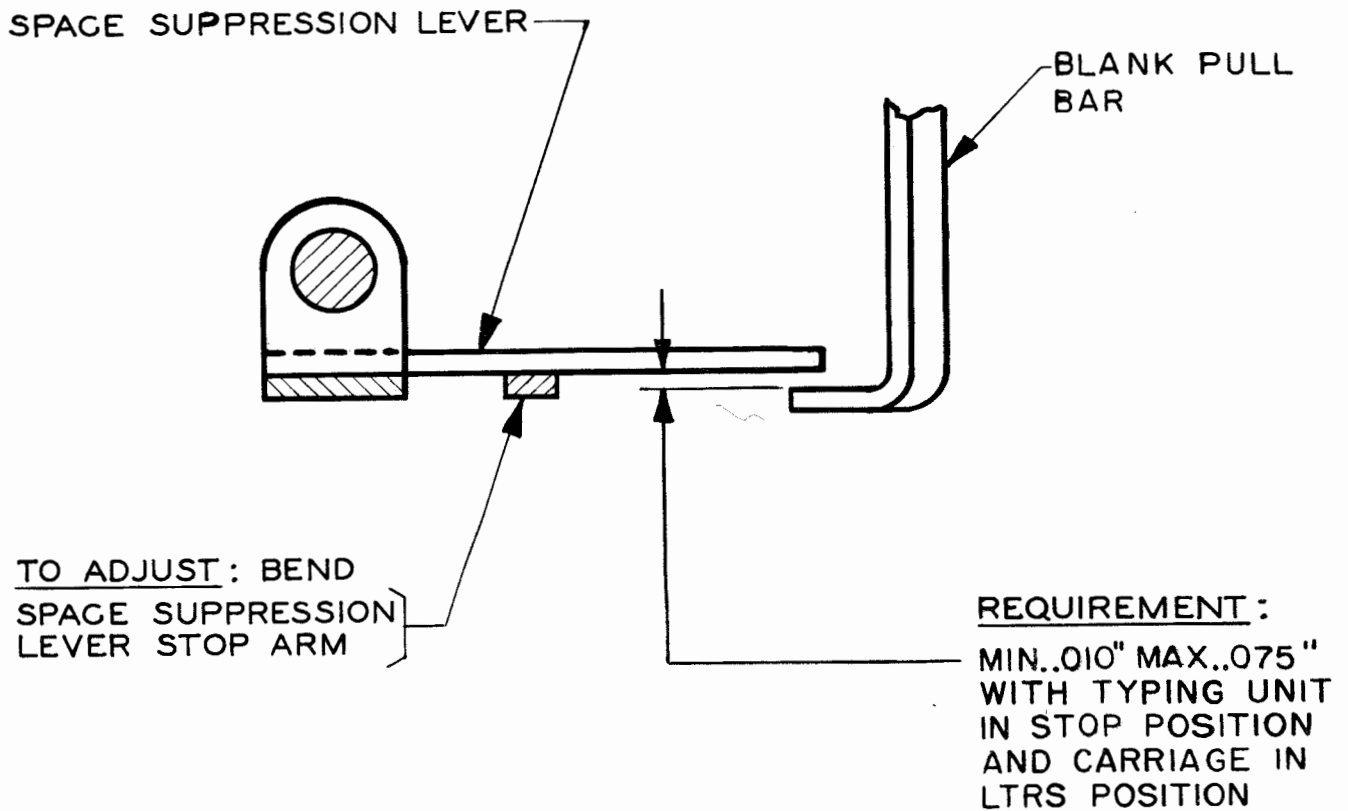

Figure 9

REQUIREMENT

MIN. .006" MAX. .040"  
WITH CARRIAGE IN  
FIGS. POSITION  
AND BLANK PULL  
BAR IN ITS CODE  
BAR SETTING

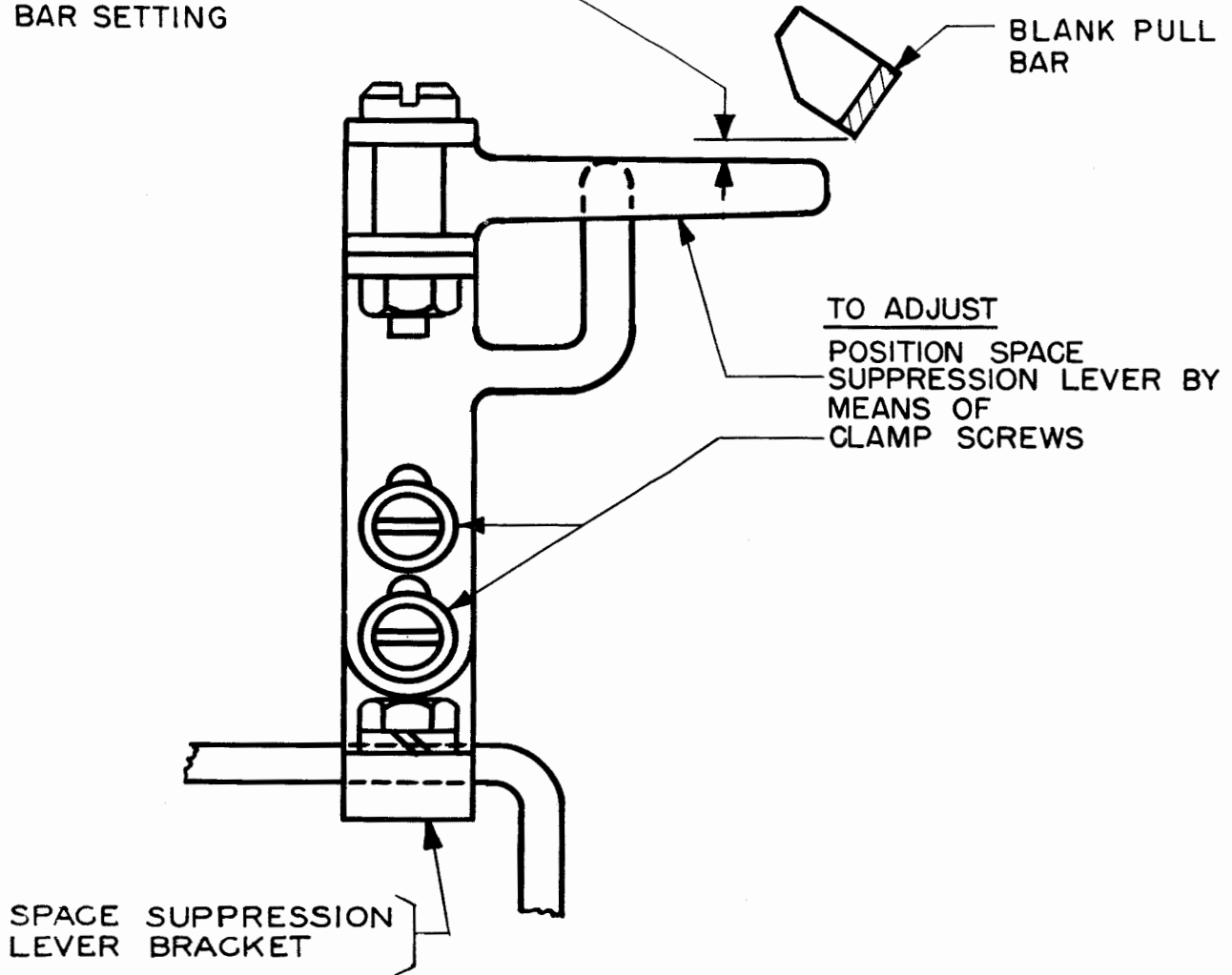

Figure 10

located at the base of the unit in front of the type-bar segment. The LTRS Make contacts are closed when the platen is in the LTRS position and open when the platen is in the FIGS position. The FIGS Make contacts close when the platen is in the FIGS position and open in the LTRS position.

5. 01 Contact-operating Lever: The lever should engage the bakelite tip on the long spring approximately in its center.

To Adjust: Position the contact bracket.

5.02 Platen-shift Contact Assembly (LTRS Make Type):

Note: The following adjustments of Figure 12 and 5.02 (a) and (b) should be made only when the parts are obviously out of adjustment. Remove the contact assembly and bracket except for the adjustments involving the operating lever. (See Figure 12.)

(a) The contact pressure should be minimum 1 ounce, maximum 2 ounces when the



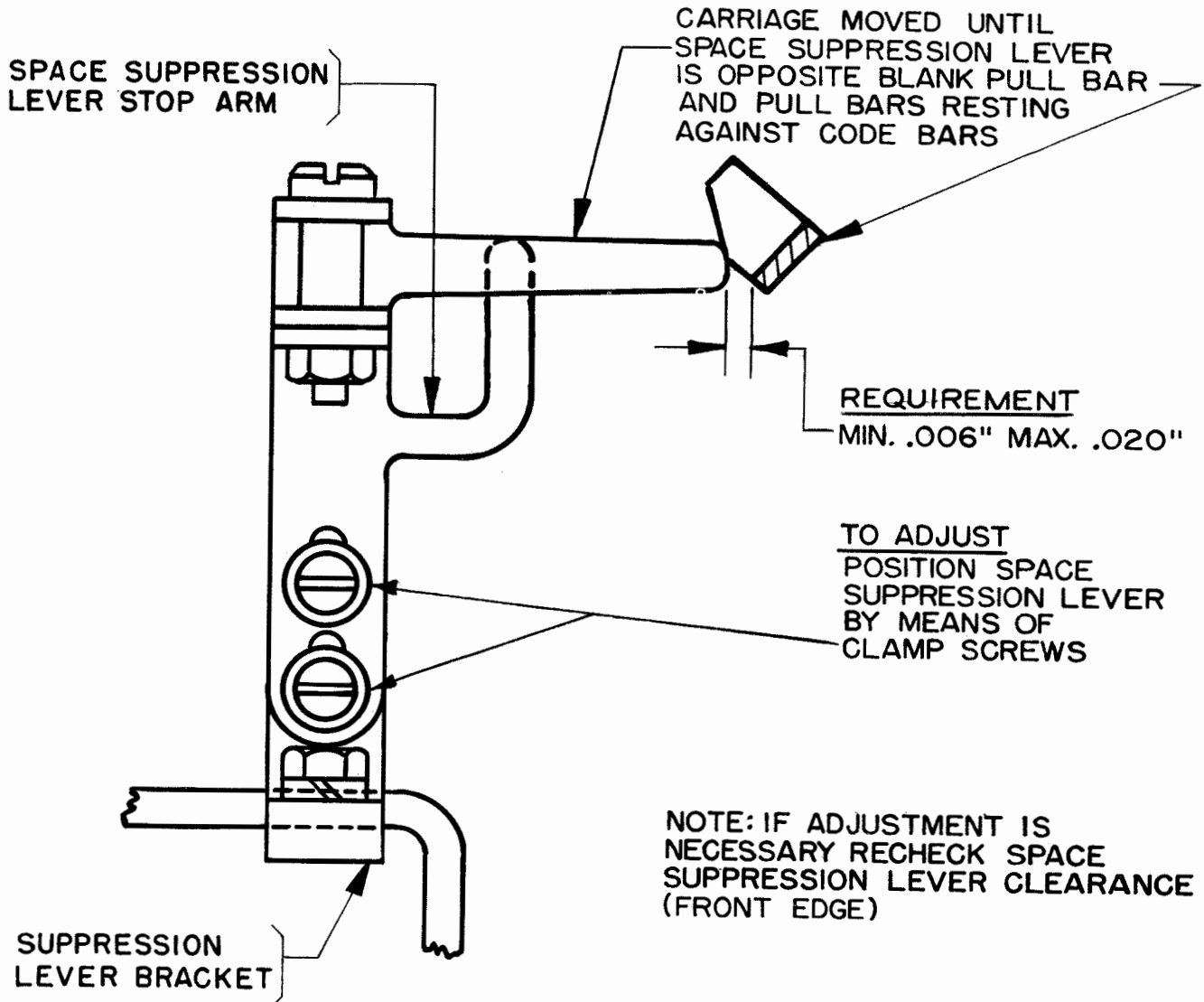

Figure 11

long contact spring is in its operated position. (See Figure 12.)

To Gauge: Insert a 0.040-inch wire gauge between the insulator cover and the long contact spring and press it toward the mounting-screws until the short contact spring is separated from its stiffener by minimum 0.004 inch, maximum 0.010 inch. Hook the pull-end of an 8-ounce scale over the short contact spring at the contact and pull at right angles to the spring.

To Adjust: Bend the short contact spring.

Note: Remount the contact assembly and recheck 5.01.

(b) Clearance between the lower contact springs and their stiffeners should be maximum 0.004 inch with the platen in the LTRS (rear) position. (See Figure 12.)

To Adjust: Position the operating lever.

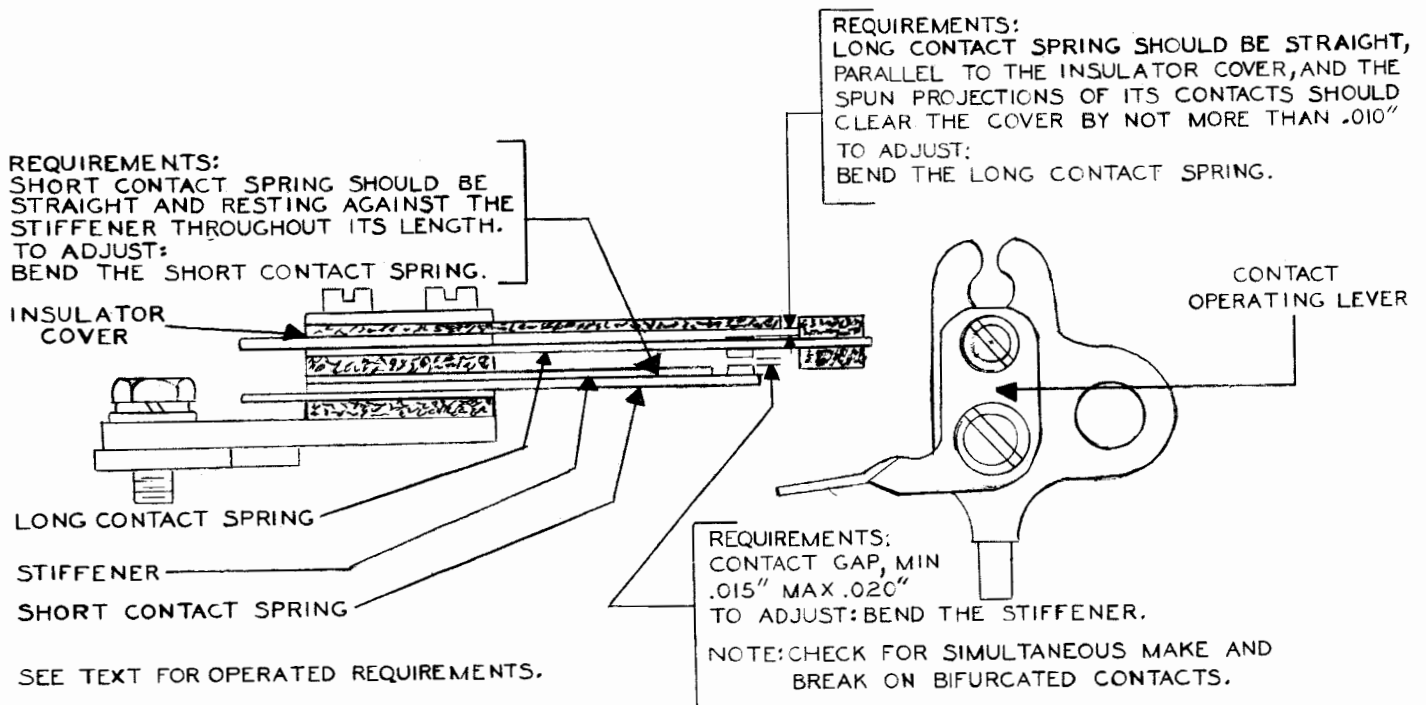

Figure 12

5. 03 Platen-shift Contact Assembly (FIGS Make Type):

Note 1: The following adjustments of Figure 13 and 5.03, Note 3, should be made only when the parts are obviously out of adjustment. Remove the contact and bracket assembly except for the adjustments involving the operating lever. (See Figure 13.)

Note 2: Remount the contact assembly and bracket and recheck 5.01.

Note 3: There should be a gap of minimum 0.015 inch, maximum 0.020 inch between the upper and lower contacts with the platen in the LTRS (rear) position. (See Figure 13.)

To Adjust: Position the operating lever.

6. POSITIVE CARRIAGE SHIFT (OLD STYLE)

Note 1: This set of parts (TP83969) overcomes irregularities in shifting caused by the use of automatic tape winders or by handling of the tape at the time the platen carriage is shifting. The carriage is positively moved to the FIGS position and momentarily locked therein during the shifting cycle.

Note 2: Old Style refers to units not equipped with new style TP84584 release pullbar.

6.01 FIGS Locking Pawl: The side of the pawl should be parallel to the side of the carriage shift-plate. (See Figure 14.)

To Adjust: Position the locking pawl post.

6.02 FIGS Stop-screw: With the carriage in the FIGS position, the figure 2 should print in the middle of the platen-roll.

Gauge by eye.

To Adjust: Position the FIGS stop-screw.

6.03 Carriage Locking-toe: With the platen in the LTRS position, the letter W should print in the middle of the platen-roll. (See Figure 15.)

Gauge by eye.

To Adjust: Loosen the carriage locking-toe mounting-screw and position the carriage locking-toe. Tighten the mounting-screw.

REQUIREMENTS:  
SHORT CONTACT SPRING SHOULD BE STRAIGHT AND RESTING AGAINST THE STIFFENER THROUGHOUT ITS LENGTH.  
TO ADJUST: BEND SHORT CONTACT SPRING.

REQUIREMENTS:  
MIN .010" MAX .020" BETWEEN SHORT CONTACT AND INSULATOR COVER WITH LONG CONTACT SPRING HELD CLEAR.  
TO ADJUST: BEND THE STIFFENER.

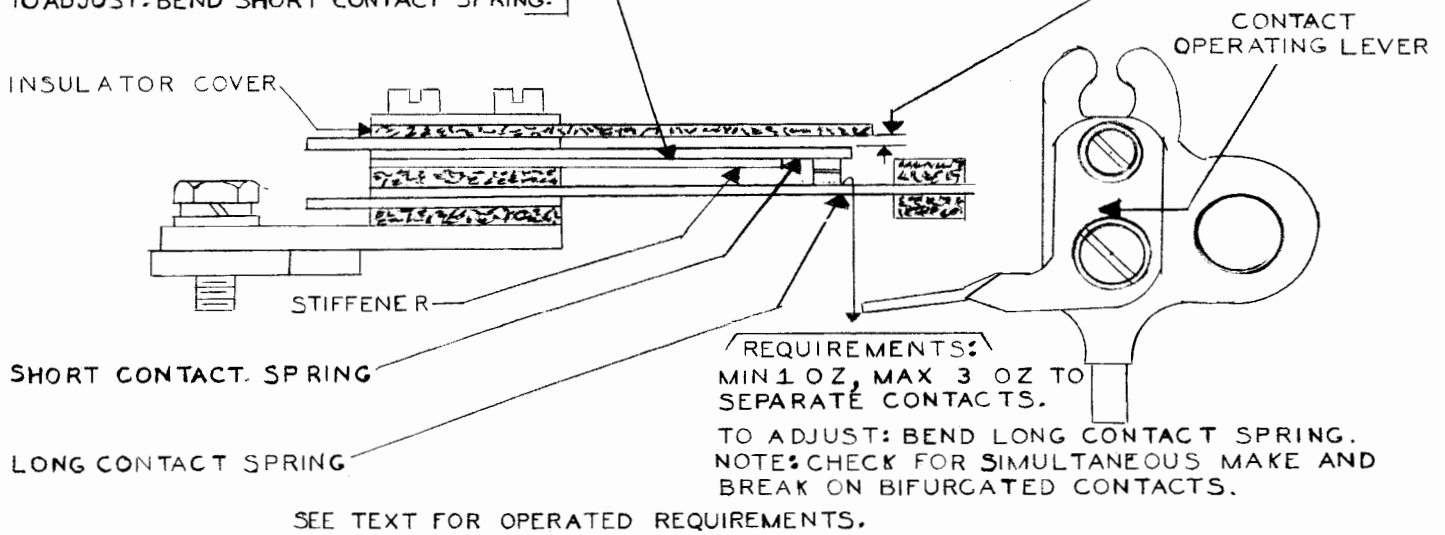

Figure 13

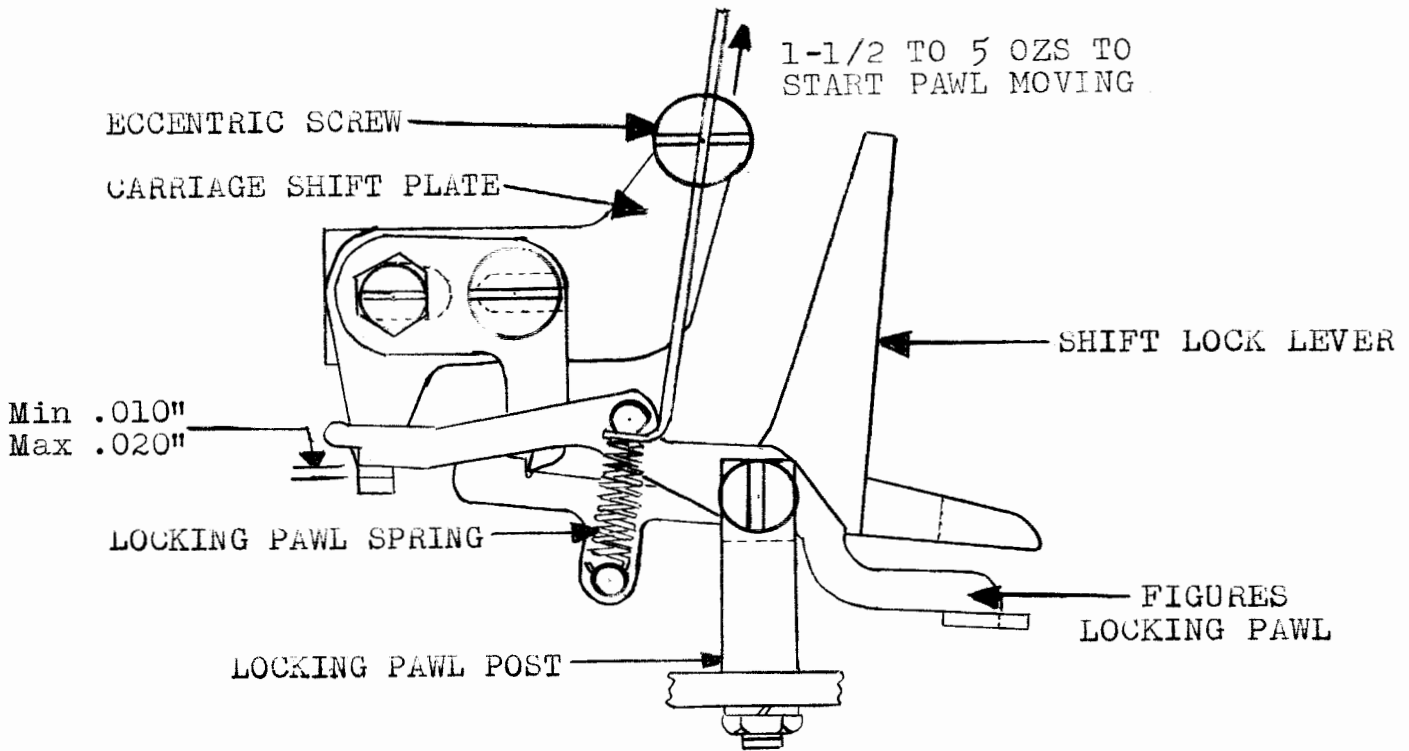

Figure 14

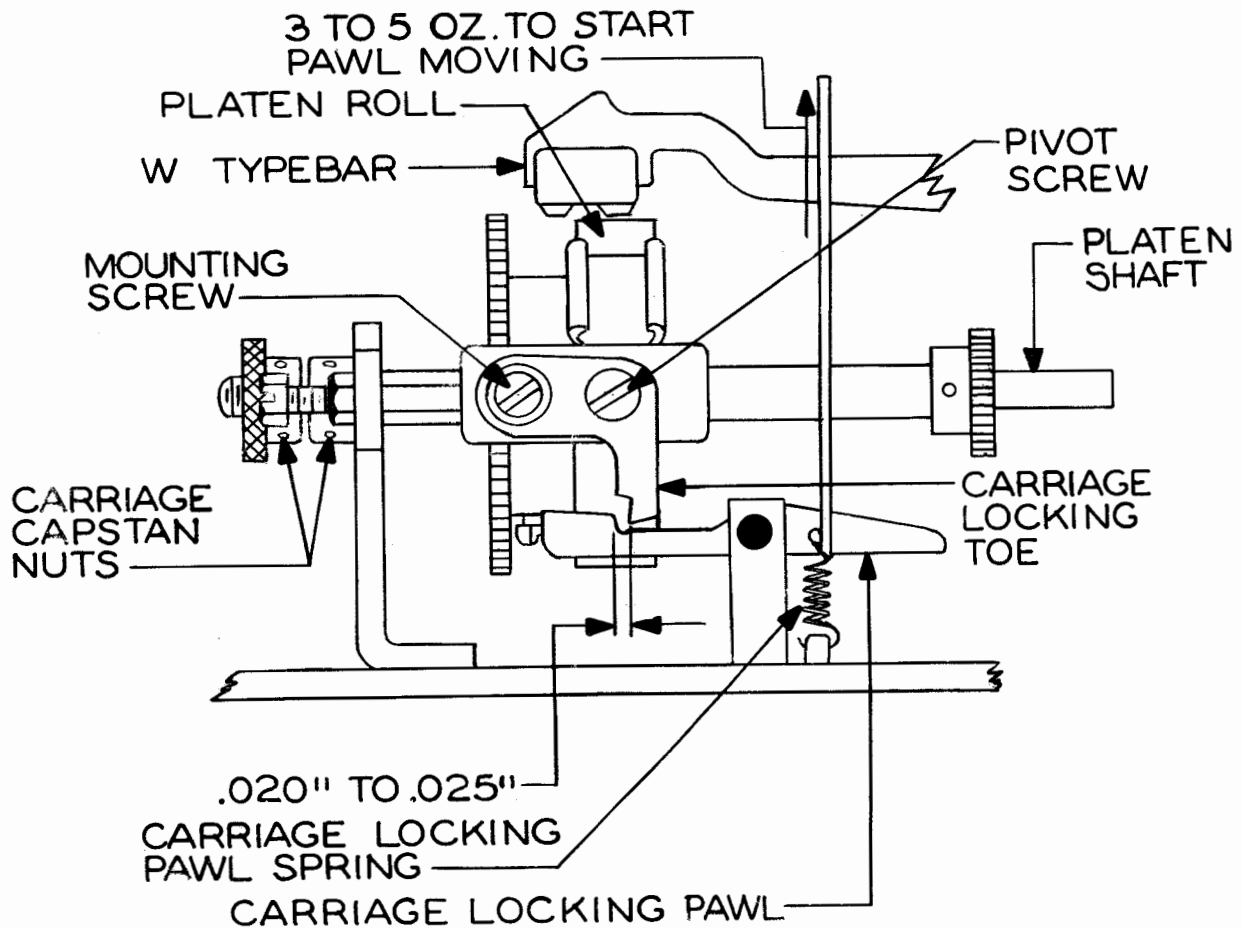

Figure 15

**6.04 Carriage Capstan Nuts:** The carriage locking-toe should overtravel the edge of the notch in the carriage locking pawl by minimum 0.020 inch, maximum 0.025 inch when the carriage capstan nuts are against the front carriage bearing. (See Figure 15.)

**To Adjust:** Position the carriage capstan nuts.

**6.05 Carriage-shift Plate:**

(a) With the carriage in the FIGS position and the FIGS locking pawl held downward against the projection on the shift-plate, there should be minimum 0.010 inch, maximum 0.020 inch clearance between the locking surface of the locking pawl and the vertical surface of the projection on the carriage shift-plate. (See Figure 16.)

(b) With the carriage in the LTRS position, set up the BLANK combination and rotate

the motor until the main bail is in its uppermost position. There should then be minimum 0.010 inch, maximum 0.020 inch clearance between the lower surface of the pawl and the upper surface of the projection on the shift-plate when the carriage is being moved manually from the LTRS to the FIGS position. (See Figure 14.)

**To Adjust:** Loosen the two screws that attach the carriage locking-toe and the carriage shift-plate to the carriage. Position the shift-plate horizontally to the front or rear to meet the requirement of (a) and vertically to meet the requirement of (b) above. Tighten the shoulder screw (rear) only; reposition the tape guide and tighten the shoulder-screw lock-nut.

**6.06 Shift-plate Eccentric:** With the carriage in the FIGS position, FIGS combination selected and the motor rotated until the main

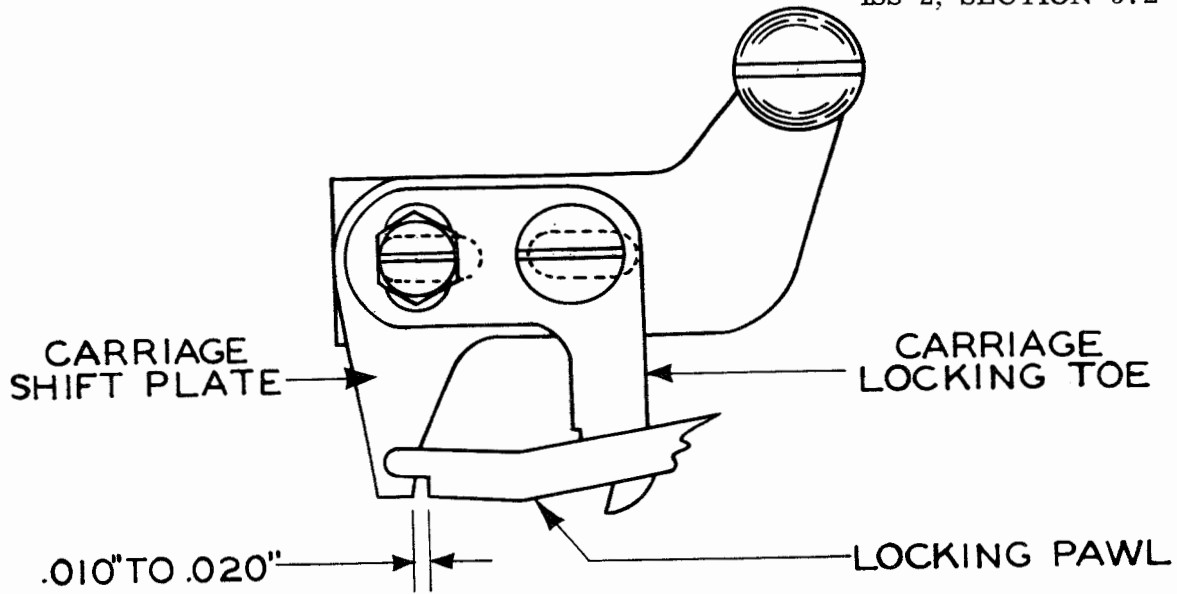

Figure 16

bail has attained its extreme upward position (assist the bail manually), there should be minimum 0.010 inch, maximum 0.040 inch clearance between the head of the eccentric screw and the upper extension of the shift lock lever. (See Figure 17.)

To Adjust: Position the eccentric screw.

Note: In order to assure alignment of the shift lock lever and the eccentric on the shift-plate, shims (TP8896) are provided for use as required to take up any excessive play that may be present between the lock lever and the TP83960 spacer washer.

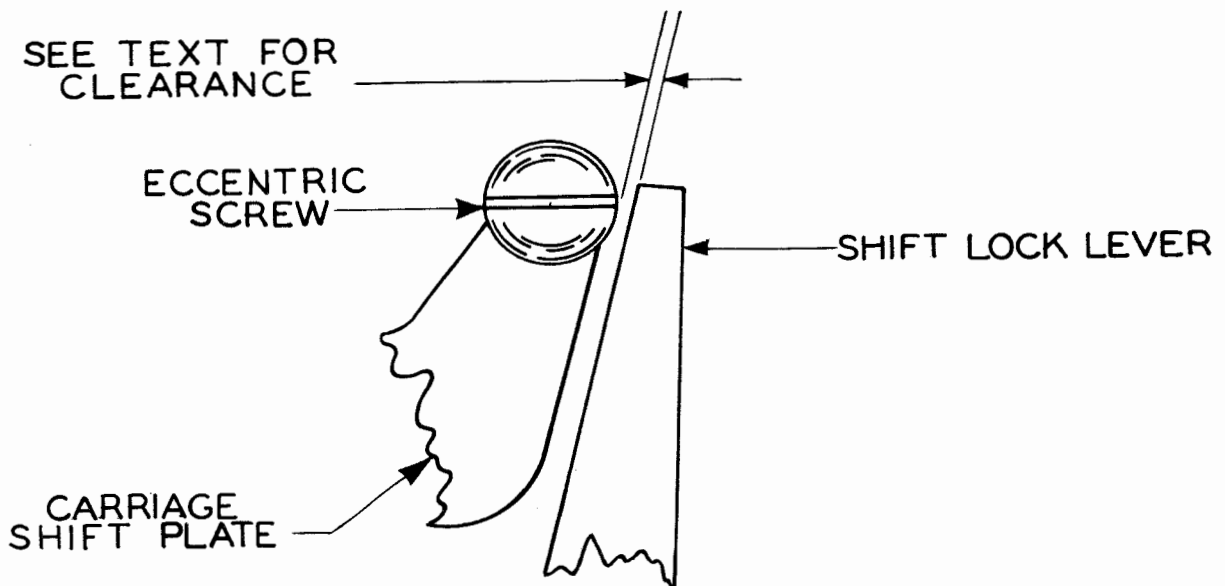

Figure 17

## SECTION 572-100-700

6.07 FIGS Locking Pawl Spring: It should require minimum 1-1/2 ounces, maximum 5 ounces to start the pawl moving when the carriage is in the LTRS position and the FIGS pullbar is in its unoperated position. (See Figure 14.)

To Gauge: Hook an 8-ounce scale over the spring post on the FIGS locking pawl and pull vertically upward.

Note: After completion of these adjustments, place the carriage in the LTRS position, select the FIGS combination and slowly rotate the motor. Observe that the shift lock lever disengages from the locking-toe before the vertical-shift lock-lever extension touches the carriage shift-plate eccentric. If necessary, readjust the shift-plate eccentric.

### 7. POSITIVE CARRIAGE SHIFT (NEW STYLE) (TP83969)

Note: New Style refers to units equipped with the new-style TP84584 release pullbar. The lower end of the redesigned TP84584 pullbar assembly is turned over at right angles to the vertical portion. For application, see 6.

7.01 FIGS Locking Pawl: The side of the pawl should be parallel to the side of the carriage shift-plate. (See Figure 14.)

To Adjust: Position the locking pawl post.

7.02 FIGS Stop-screw: With the carriage in the FIGS position, the figure 2 should print in the middle of the platen-roll.

Gauge by eye.

To Adjust: Position the FIGS stop-screw.

7.03 Carriage Locking-toe: With the carriage in the LTRS position, the letter W should print in the middle of the platen-roll. (See Figure 15.)

Gauge by eye.

To Adjust: Loosen the carriage locking-toe mounting-screw and position the carriage locking-toe. Tighten the mounting-screw.

7.04 Carriage Capstan Nuts: The carriage locking-toe should overtravel the edge of the notch in the carriage locking pawl by

minimum 0.020 inch, maximum 0.025 inch when the carriage capstan nuts are against the front carriage bearing. (See Figure 15.)

To Adjust: Position the carriage capstan nuts.

### 7.05 Carriage Shift-plate:

(a) There should be minimum 0.010 inch, maximum 0.020 inch clearance between the locking surface of the locking pawl and the vertical surface of the projection on the carriage shift-plate when: (See Figure 14.)

(1) FIGS combination is selected.

(2) The motor is rotated until the main bail is in its uppermost position.

(3) The FIGS locking pawl is held against the projection on the shift-plate.

(b) There should be minimum 0.020 inch, maximum 0.040 inch clearance at the closest point between the lower surface of the release pull bar and the top surface of the rear portion of the FIGS locking pawl when: (See Figure 18.)

(1) The carriage shift-plate eccentric is rotated so that it does not interfere with the shift lock lever.

(2) The carriage is in the LTRS position and the FIGS combination selected.

(3) The motor rotated until the shift lock lever just disengages from the carriage locking-toe.

(4) The FIGS locking pawl is resting against the upper surface of the carriage shift-plate extension.

(5) The play is taken up between the carriage frame and the front-bracket guide-post to make the clearance a minimum.

To Adjust: Position the carriage shift-plate horizontally toward the front or rear to meet requirement (a) and vertically to meet requirement (b). Recheck the carriage locking-toe.

7.06 Shift-plate Eccentric: With the carriage in the LTRS position, select the FIGS

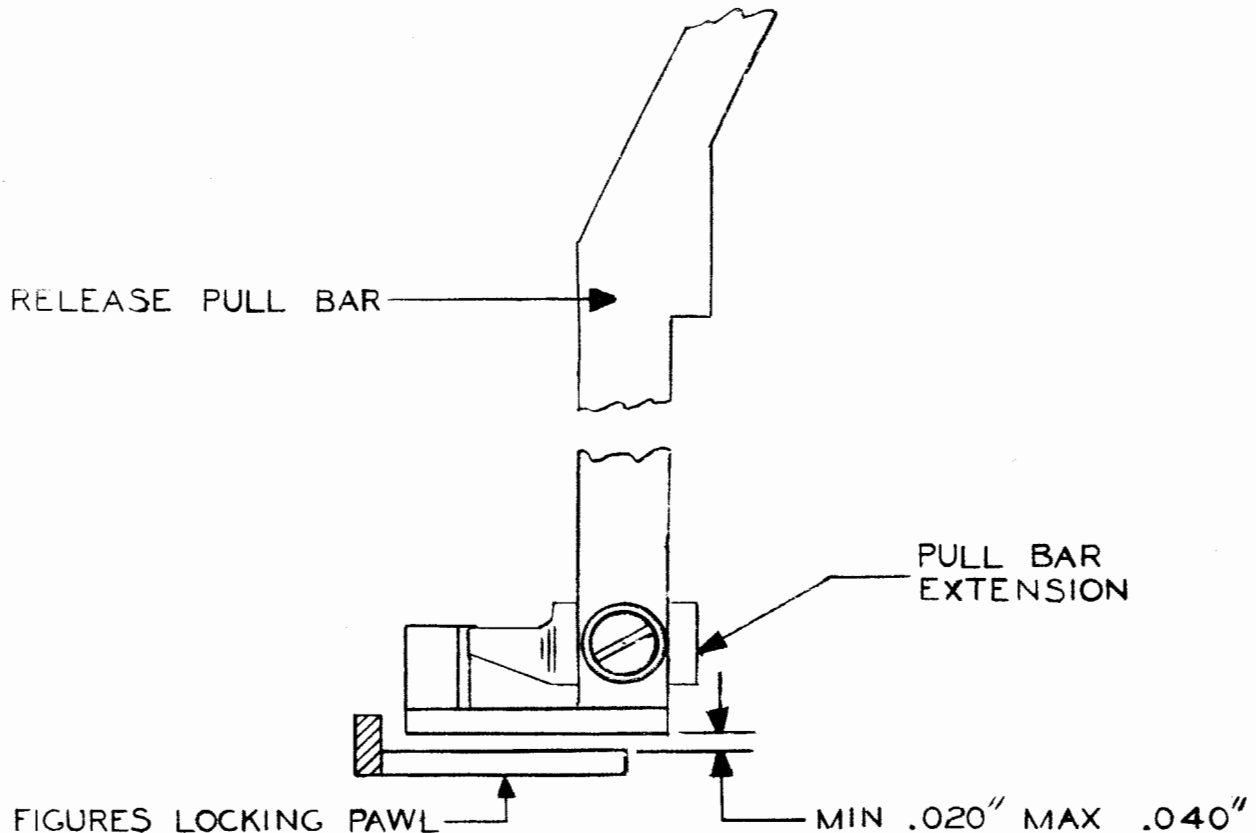

Figure 18

combination and rotate the motor until the shift lock lever just disengages from the carriage locking-toe. There should be minimum 0.065 inch, maximum 0.075 inch clearance between the carriage shift-plate eccentric screw and the shift lock lever. (See Figure 17.)

To Adjust: Position the eccentric screw.

Note: In order to assure alignment of the shift lock lever and the eccentric on the shift-plate, shims (TP8896) are provided for use as required to take up any excessive play that may be present between the lock lever and the TP83960 spacer washer.

7.07 FIGS Locking Pawl Spring: It should require minimum 1-1/2 ounces, maximum 5 ounces, to start the pawl moving when the carriage is in the LTRS position and the FIGS pull-bar is in its unoperated position. (See Figure 14.)

To Gauge: Hook an 8-ounce scale over the spring post on the FIGS locking pawl and pull vertically upward.

Note: After completion of these adjustments, place the carriage in the LTRS position, select the FIGS combination and slowly rotate the motor. Observe that the shift lock lever disengages from the locking-toe before the vertical-shift lock-lever extension touches the carriage shift-plate eccentric. If necessary, readjust the shift-plate eccentric.

## 8. PULLBAR-CONTACT MECHANISM

Note: The pull-bar contacts are located on a bracket above the pullbars and are operated by pullbars having a hooked extension which engages the long contact spring of the break-make spring combination. The contacts are designed for momentary operation. (TP97125: Any position except 25, 26.) (TP97140: Only positions 25, 26.)

8.01 Pullbar-contact Mounting-plate: The following requirements should be met with the pullbars resting against the code-bars but not selected.

(a) The toes of the pullbar hooks should be as close as possible to 0.442 inch above the contact mounting-plate. (See Figure 19.)

Gauge with the TP99391 gauge.

To Adjust: Add or remove shims between the pullbar contact mounting-plate and the mounting posts.

(b) The toes of the two end and one middle pullbar hooks should be as close as possible to 0.620 inch in front of the contact mounting plate. (See Figure 20.)

Gauge with the TP99391 gauge.

To Adjust: Loosen the nuts securing the mounting-plate and position the plate. Tighten the nuts.

8.02 Pullbar Guard: The pullbar guard should meet the following requirements with the main bail in its lowest position: (See Figure 20.)

(a) With the type-bars resting against the back stop, it should not be possible manually to disengage the pullbars from their guide slots.

(b) With the type bars held against the platen, there should be some clearance between the pullbars and the pullbar guard.

Note: For pullbars not having associated type-bars the clearance in (b) is checked by raising the pullbar by hand to a point where

there is minimum clearance between the pullbar and the pullbar guard, the pullbar being in contact with the main-bail. (Shift the platen to permit raising of the pullbar.)

To Adjust the End Pullbars: When the guard does not meet the requirements in (a) and (b), add or remove washers or shims between the guard and the frame on the side not meeting the requirement. (The correct washers and shims measure 0.028 inch and 0.004 inch in thickness, respectively.)

To Adjust the Middle Pullbars: When the guard does not meet the requirements in (a) and (b), loosen one guard mounting-screw and push or pull the guard until the requirement is met.

8.03 Pullbar Contact Assembly:

Note: To insure uniformity in checking adjustments where pullbars are to be placed in the nonselected position, select the pullbar and, by manually holding it out of selection, create the nonselected condition by moving the No. 1 code bar into its path.

(a) With the pullbar in the selected position and with some clearance between it and the main bail, there should be a preliminary clearance of approximately 0.020 inch between the tip of the pullbar hook and the low flat surface of the long contact spring insulator. (See Figure 21.)

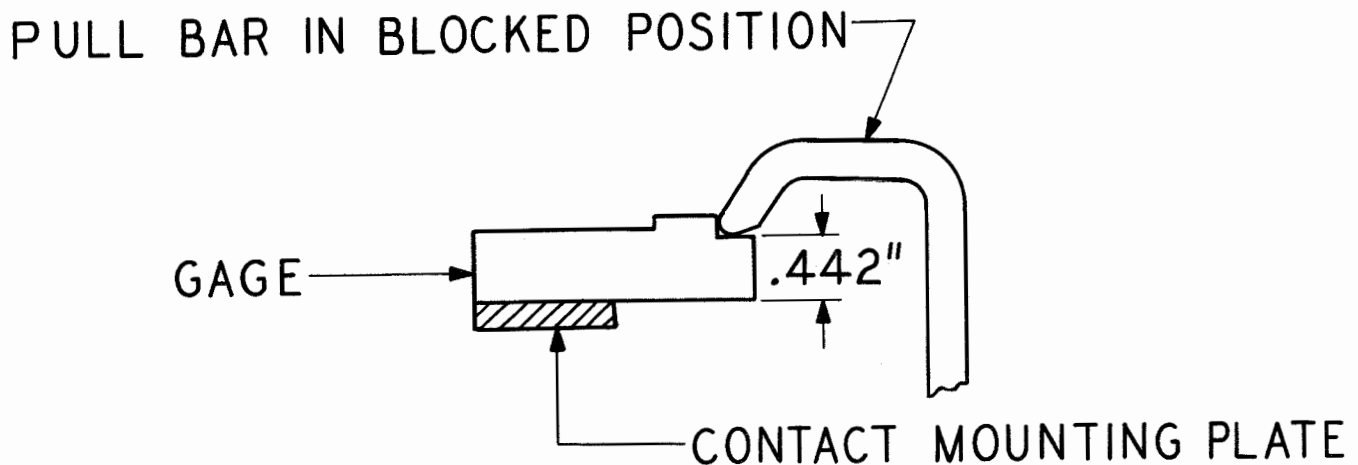

Figure 19



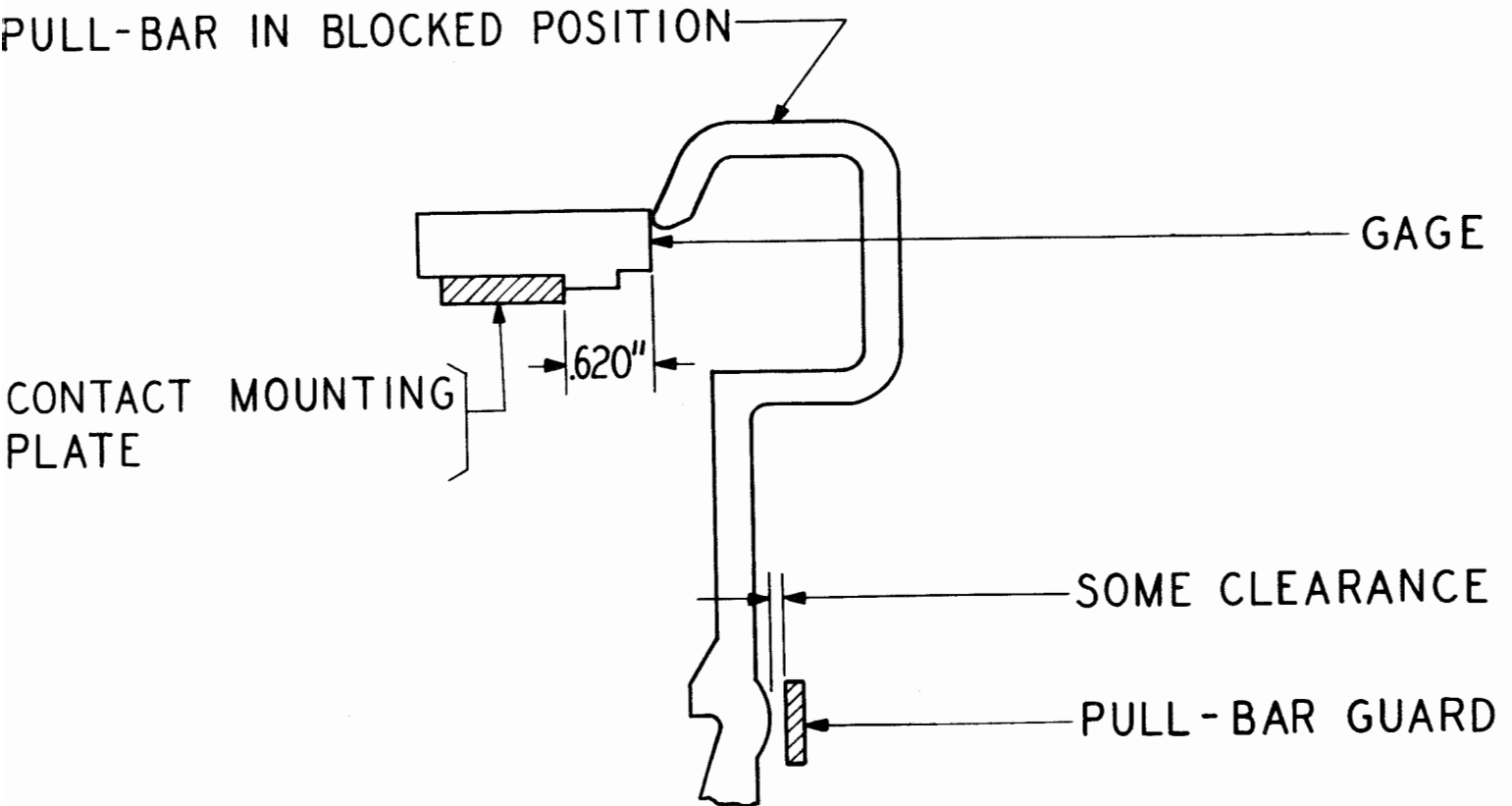

Figure 20

Note: This clearance may be affected by subsequent adjustments in this paragraph. There is no fixed requirement for the final clearance.

To Adjust: Bend the long contact spring for minimum clearance at this point and then obtain the 0.020 inch by bending the upper contact spring.

(b) With the pullbar in a selected position and play taken up by pressing lightly downward on the pullbar, there should be minimum 0.004 inch, maximum 0.015 inch clearance between the lower sloping surface of the long contact spring insulator and the adjacent surface of the pullbar hook. (See Figure 21.)

To Adjust: Position the contact assembly.

Note: To reduce bounce or chatter of the H pullbar contact, adjust the clearance in (c) and the tension in (d) toward their maximum limits.

(c) With the pullbar in its nonselected position and the upper contact spring against its stop, there should be minimum 0.015-inch, maximum 0.025-inch clearance between the long spring contact and the upper spring contact. (See Figure 22.)

To Adjust: Bend the upper-contact-spring stop.

(d) With the pullbar in nonselected position, it should require minimum 1-1/2 ounces, maximum 2-1/2 ounces to separate the upper contact spring from its stop. (See Figure 22.)

To Gauge: Hook an 8-ounce scale under the upper spring at the contact and pull vertically.

To Adjust: Bend the upper contact spring.

(e) With the pullbar in selected position, it should require minimum 1/2 ounce, maximum 1-1/2 ounces to separate the long

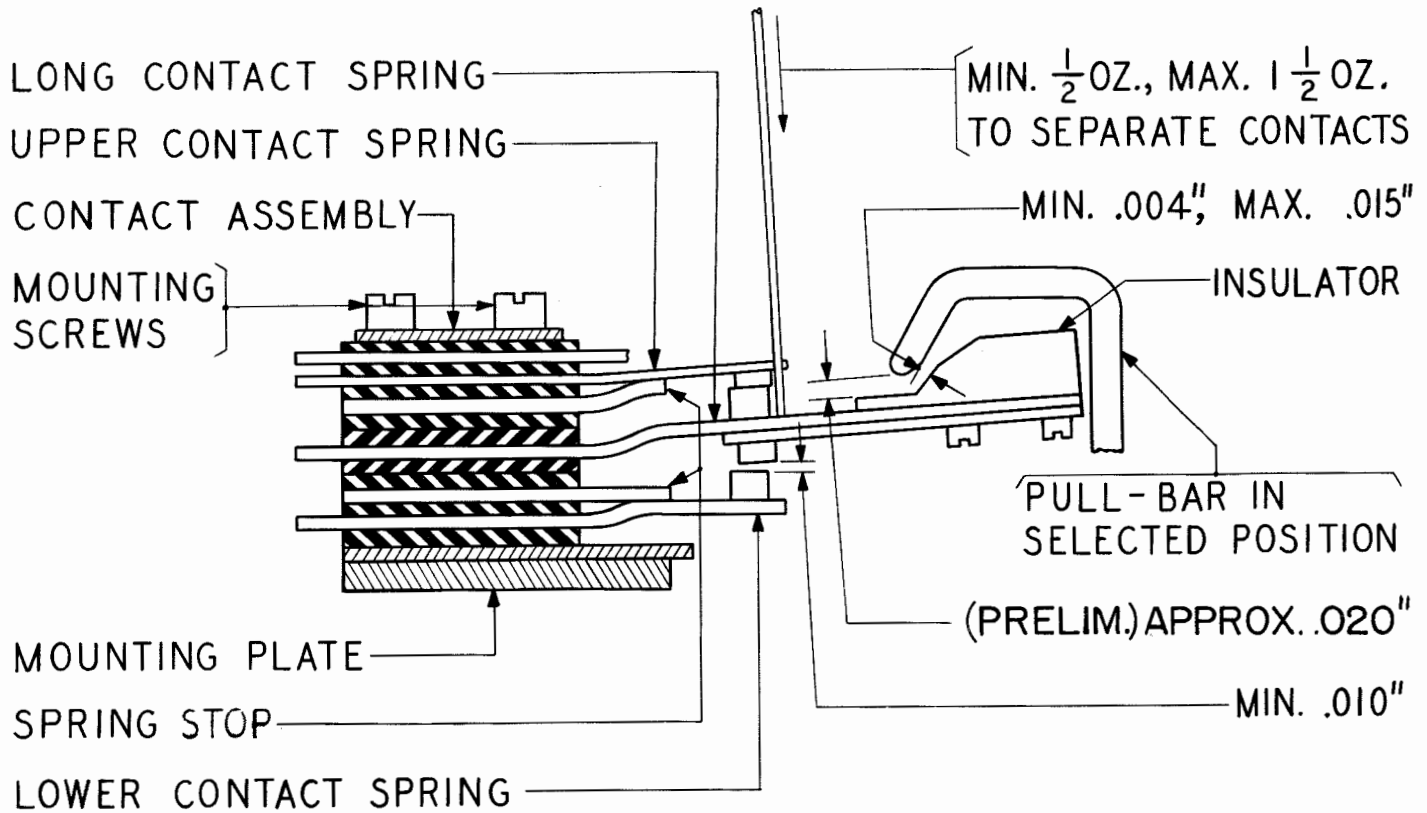

Figure 21

spring contact from the upper spring contact. (See Figure 21.)

To Gauge: Apply the push end of an 8-ounce scale to the long contact spring at the contact and push downward.

To Adjust: Bend the long contact spring and recheck requirement (c).

(f) There should be minimum 0.002 inch, maximum 0.006 inch clearance between the lower contact spring and its stop when the pullbar is in its nonselected position. (See Figure 22.)

To Adjust: Bend the lower-contact-spring stop.

(g) It should require not more than 1 ounce to separate the lower spring contact from the long spring contact with the pullbar in nonselected position. (See Figure 22.)

To Gauge: Apply the push end of an 8-ounce scale to the lower contact spring at the contact and push downward.

To Adjust: Bend the lower contact spring and recheck (f).

(h) With the pullbar in its selected position, check that there is at least 0.010 inch clearance between the lower spring contact and the long spring contact. (See Figure 21.)

Gauge by eye.

Note: The bending of springs and stops sets up stresses which tend to cause changes in permanent adjustments. To stabilize the adjustments, each pile-up of springs should be operated either manually or under power at least 20 times and then rechecked and readjusted as required.

## 9. PUSH TAPE-FEED MECHANISM (TP87374)

Note: This set of parts converts pull tape-feed to push tape-feed. The push tape-feed mechanism is similar to the pull tape-feed mechanism except that the feed mechanism is on the opposite side of the platen roll. This is to keep the mechanism out of the way

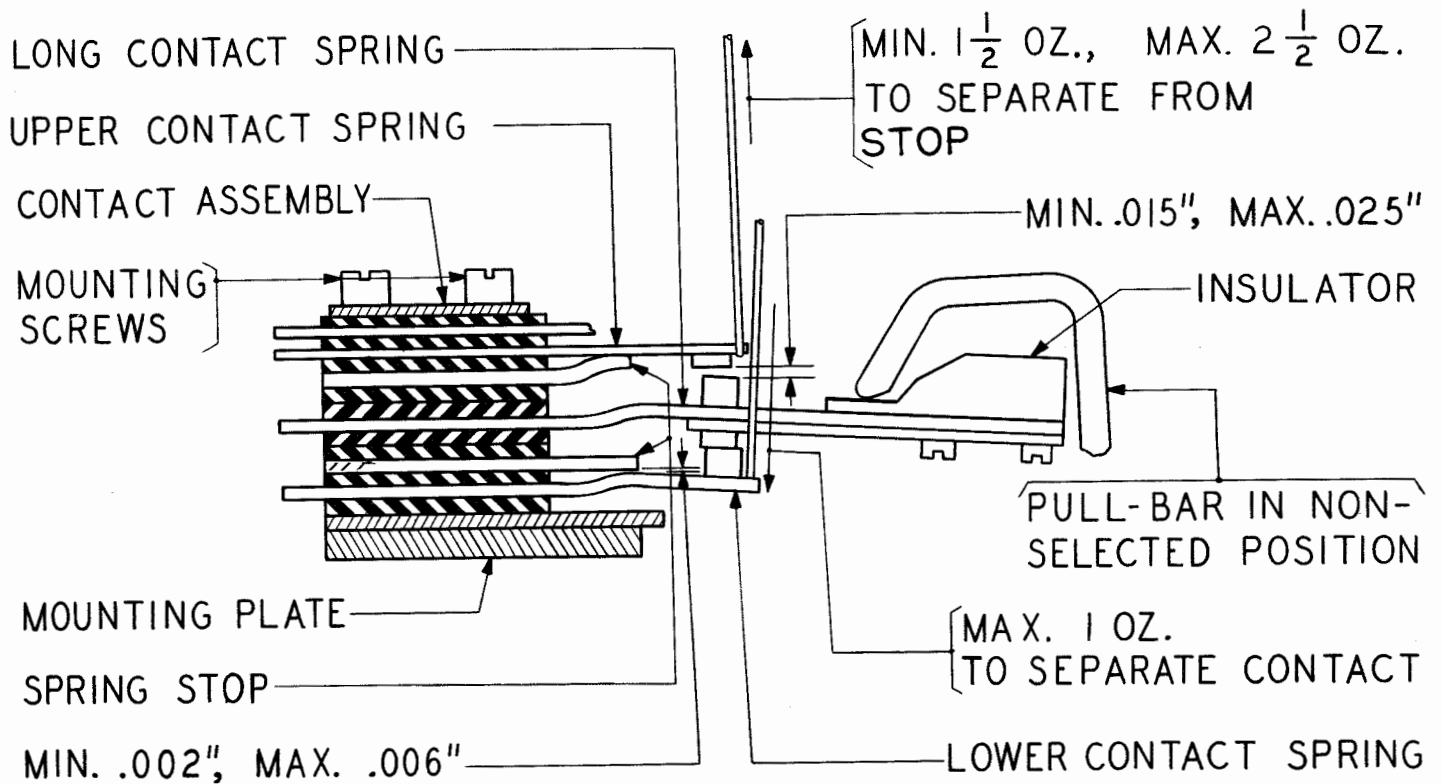

Figure 22

of the printed portion of the tape so that it can be read practically up to the printing point.

- 9.01 Carriage Locking-toe: (See 7.03.)  
 9.02 Right Tape Guide

(a) When a piece of tape is inserted through both tape guides, it should align with the platen, and the printing should be in the center of the tape. (See Figure 23.)

To Adjust: Position the right tape guide and tighten the mounting screw.

(b) The free end of the right tape guide should align with the point of contact between the platen and the feed roll.

To Adjust: If necessary, adjust by bending the guide.

- 9.03 Center Tape Guide: The center tape guide should clear the platen by 0.006 inch to 0.012 inch when the feed roll is resting on the platen. (See Figure 23.)

To Adjust: Loosen the nut on the rear end of the feed roll journal and position the guide.

- 9.04 Tape Feed Roll Spring Tension: With the feed roll resting on the platen, hook a 32-ounce scale over the end of the feed roll bearing screw and pull at a right angle to the right tape guide, away from the platen roll. It should require 10 to 14 ounces to start the feed lever moving.

## 10. REMOTE SIGNAL BELL (OLD) (TP88894)

Note: This set of parts is used where the regular (single-stroke) bell is not sufficiently loud or where a bell is desired in another room.

### 10.01 Remote Signal Bell Contacts:

(a) Contact-levers should fully engage the heel of the bell pullbar and clear its side by at least 0.010 inch when the BELL combination is set up and the motor has been rotated by hand until the pullbar bail is in its extreme upper position. See Figure 24 for location of parts.

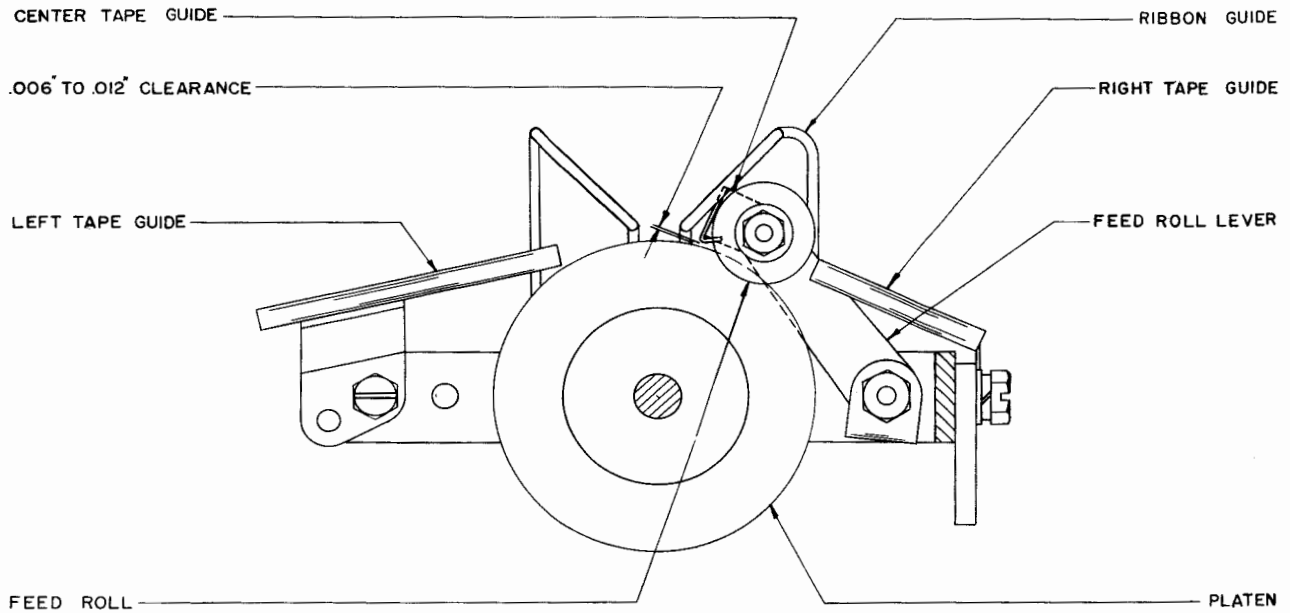

Figure 23

Gauge by eye.

To Adjust: Position the contact-bracket.

(b) Contact-levers should clear the insulator on the upper contact spring by not more than 0.006 inch when the contact-lever is held against the bell pullbar after the motor has been rotated by hand until the pullbar bail is in its extreme lower position. (See Figure 24.)

To Adjust: Bend the upper contact spring.

(c) The contact gap should be minimum 0.025 inch, maximum 0.035 inch when the contact-lever is held clear of the upper contact spring. (See Figure 24.)

To Adjust: Bend the stiffener.

(d) It should require minimum 1-1/2 ounces, maximum 2 ounces to move the lower contact spring from its stiffener. (See Figure 24.)

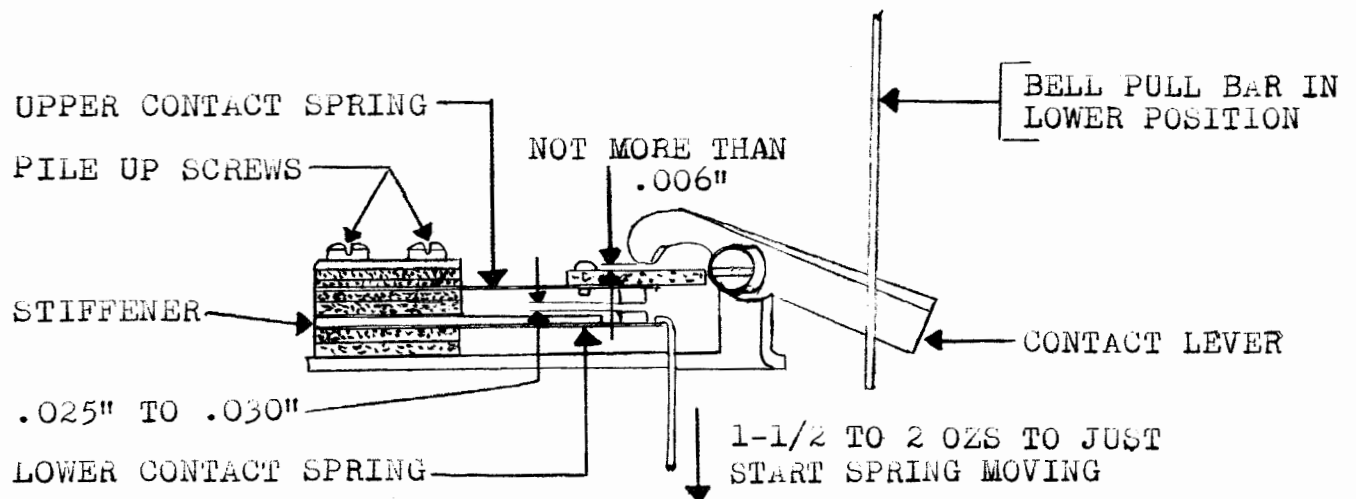

Figure 24

To Gauge: Hook the pull-end of an 8-ounce scale at the end of the lower contact spring and pull vertically.

To Adjust: Bend the lower contact spring.

Note: It may be necessary to remove the contact assembly to make the adjustments in (c) and (d) above. In this case, contact adjustments may be checked with gauges before reassembling in the typing-unit.

11. REMOTE SIGNAL BELL (NEW) (TP104479)

Note: This set of parts serves the same purpose as the TP88894 Remote Signal Bell but lengthens closure of the S contacts. (See 10.)

11.01 Remote Signal Bell Contacts:  
(See Figure 25.)

12. UNIVERSAL CONTACT MECHANISM  
(OLD-STYLE MAKE) (TP99344)

Note 1: The universal contact mechanism is located to the left of the pullbar contact mounting bracket and operates from the main

bail. The contacts make when the bail is in its highest position and break when the bail is in its lowest position.

Note 2: Old-style make contact springs are mounted horizontally and are used only on units having square bail guide-posts.

12.01 Contact Operating-lever:

(a) The contact operating-lever should clear the fully-selected Q pullbar by minimum 0.020 inch, maximum 0.060 inch when the lever is held in contact with the bail by its spring and the play in the lever is taken up in a direction to make this clearance a minimum. (See Figure 26 for location of parts.)

(b) The contact operating-lever should clear the extension on the casting that mounts the square bail-guide post by not less than 0.020 inch when the main bail is in its lowest position and the play in the lever is taken up to make this clearance a minimum. (See Figure 26 for location of parts.)

To Adjust: Shift the contact-lever bracket.

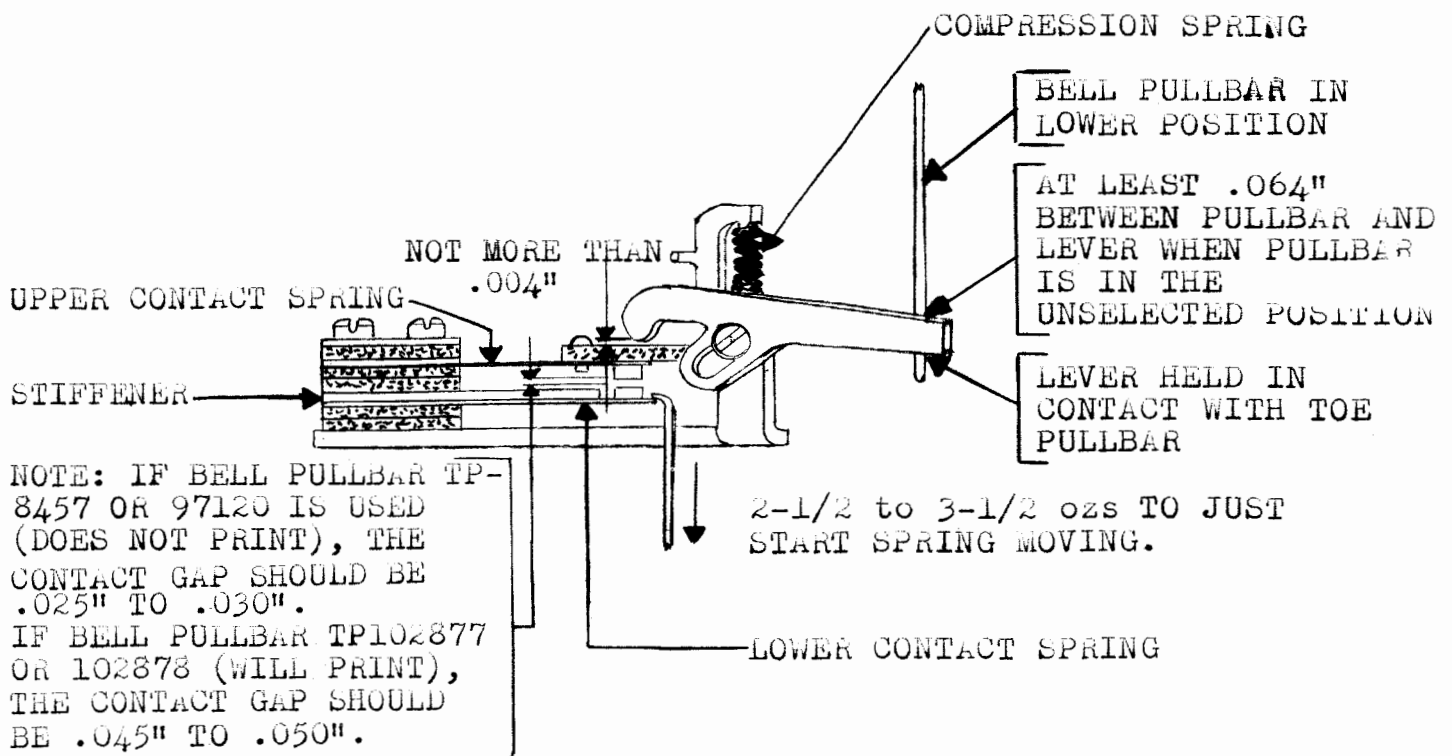

Figure 25

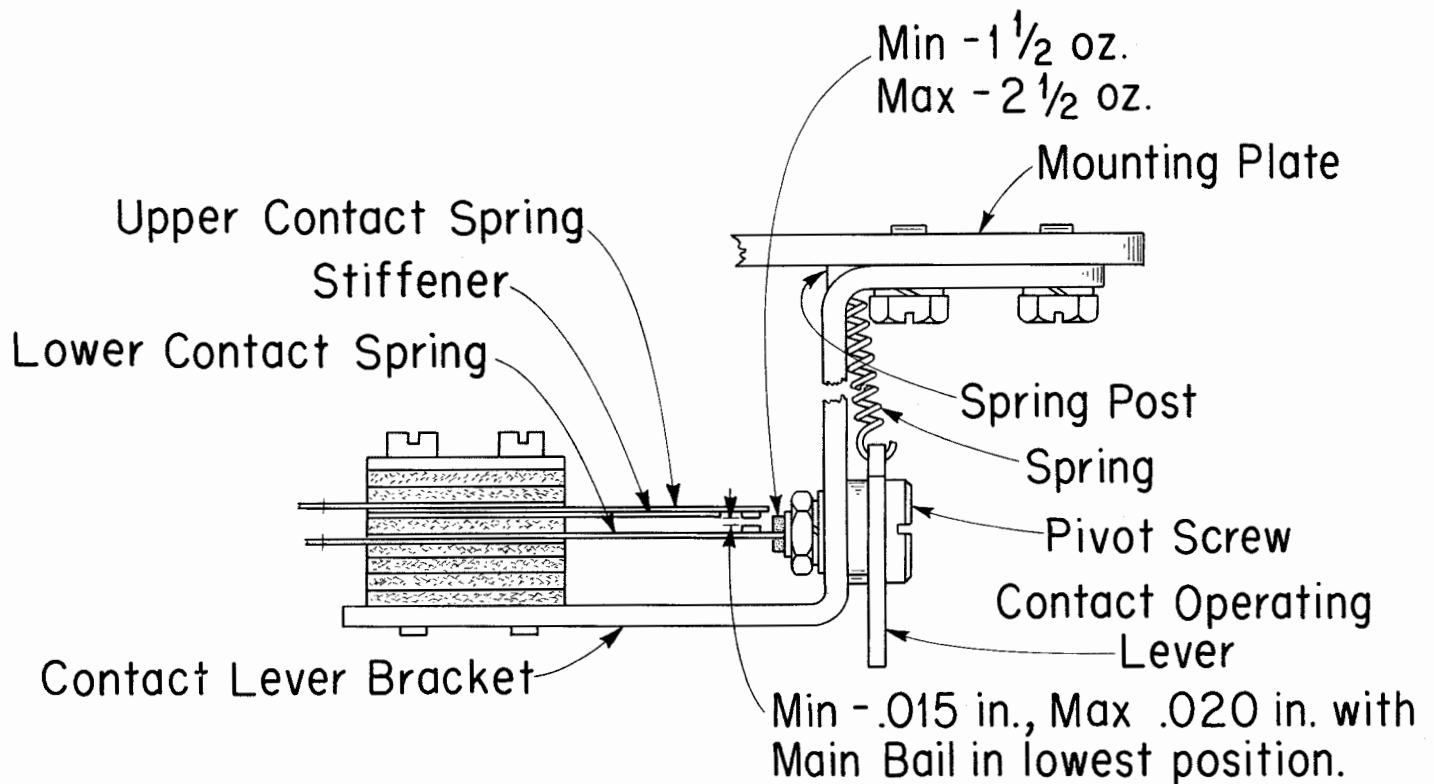

Figure 26

### 12.02 Universal Contact Assembly:

(a) The upper contact springs and their stiffeners should be straight and the springs should be in contact with their stiffeners throughout their entire length. (See Figure 26.)

To Adjust: Bend the springs and stiffeners as required. Check that both sets of contacts open and close simultaneously when the long spring is operated and released.

(b) With the main bail in its lowest position, there should be a gap of minimum 0.015 inch, maximum 0.020 inch between each set of contacts. (See Figure 26.)

To Adjust: Bend the lower contact spring.

(c) With the contact operating-lever in contact with the main bail and the main shaft rotated until the main bail rises to within minimum 0.020 inch, maximum 0.080 inch of the notches in all the pullbars, the contact operating-lever should cause the contacts to

just make. (See Figure 26 for location of parts.)

To Adjust: Position the contact operating-lever pivot-screw.

(d) With the main-bail in its highest position, it should require minimum 1-1/2 ounces, maximum 2-1/2 ounces to separate the spring contacts. (See Figure 26.)

To Gauge: Apply the push-end of an 8-ounce scale to the bakelite tip of the lower contact and push downward.

To Adjust: Bend the lower contact spring.

### 13. UNIVERSAL CONTACT MECHANISM (NEW-STYLE MAKE) (TP104471)

Note 1: The universal contact mechanism is located to the left of the pullbar-contact mounting-bracket and operates pullbar-contact from the main bail. The contacts make when the bail is in its highest position and break when the bail is in its lowest position.

Note 2: New style make-contact springs are mounted vertically on the unit and are used on units with square main-bail guide posts or those with main-bail roller guides.

13.01 Contact Operating-lever:

(a) The contact-operating-lever extension should be located approximately midway between the No. 1 and No. 2 pullbars when the main-bail is in its highest and lowest positions. (See Figure 27 for location of parts.)

To Adjust: Position the universal assembly bracket.

(b) When a pullbar, having pullbar contacts, is selected and the main-shaft is rotated until the associated top pullbar contacts just close, there should be a clearance of minimum 0.025 inch, maximum 0.035 inch between the tip of the contact operating-lever and the side of the insulator on the long

contact-spring. On units without pullbar contacts, this clearance should be approximately 1/8 inch when the main-bail is in its lowest position. (See Figure 27.)

To Adjust: Position the contact operating-lever block, keeping its top surface horizontal.

13.02 Universal Contact Assembly:

(a) The short contact springs and their stiffeners should be straight and the springs should be in contact with their stops throughout their entire length. (See Figure 27.)

To Adjust: Bend the springs and stiffeners as required. Check that both sets of contacts make and break at approximately the same time when the long contact spring is operated and released.

(b) With the main bail in its lowest position, there should be a gap of minimum 0.015

Universal Assembly Bracket

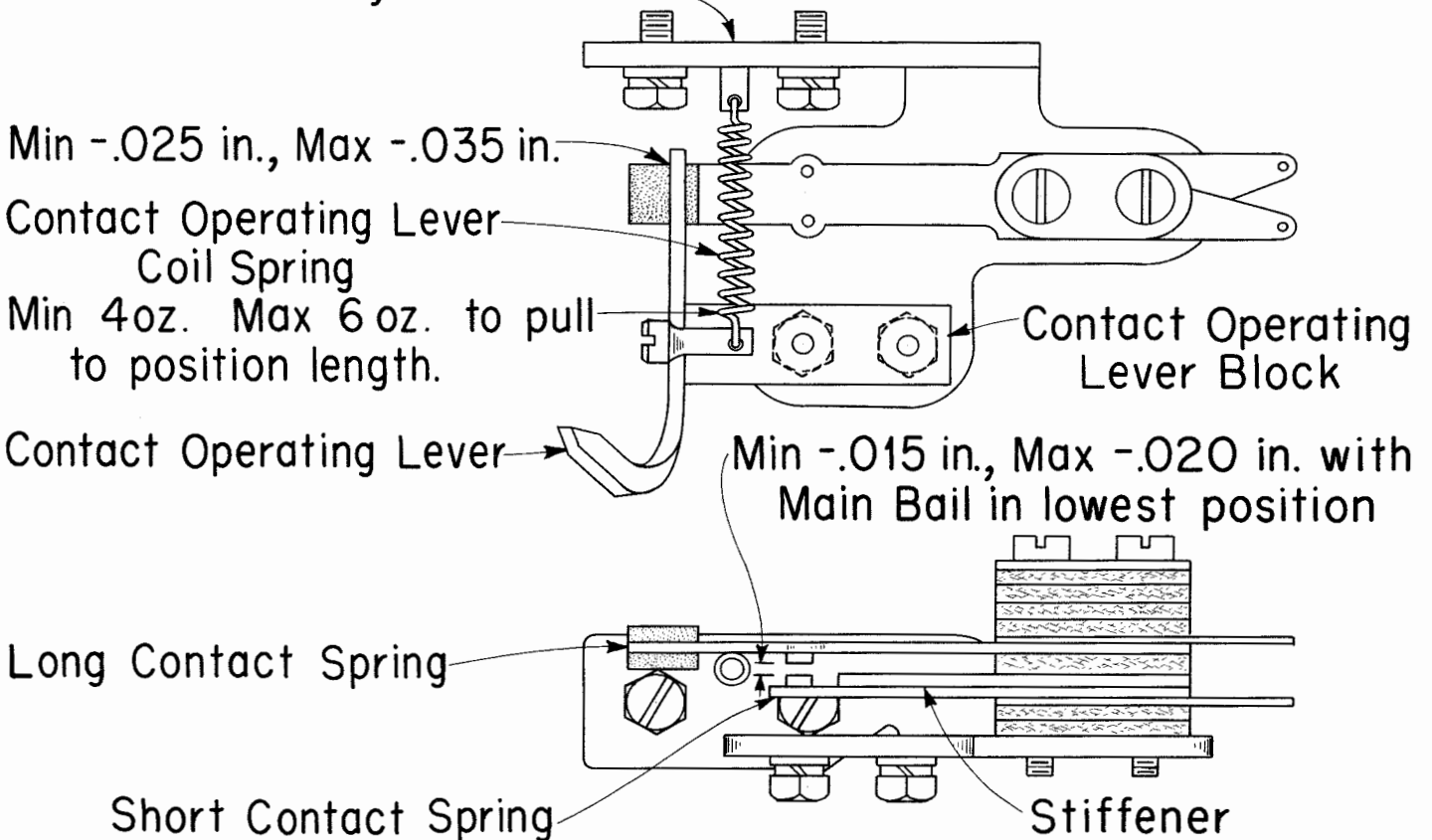

Figure 27

inch, maximum 0.020 inch between the contacts on the long and short springs. (See Figure 27.)

To Adjust: Bend the long contact-spring.

(c) With the main bail in its highest position, it should require minimum 1-1/2 ounces, maximum 2-1/2 ounces to separate each set of contacts of the long and short contact springs. (See Figure 27.)

To Gauge: Hook the pull-end of an 8-ounce scale around the short spring at the contact and pull at right angles to the spring.

(d) With the contact-operating-lever coil spring unhooked from the lever and the lever resting against the insulator tip of the long contact-spring, it should require minimum 4 ounces, maximum 6 ounces to pull the coil spring to position length. (See Figure 27.)

To Gauge: Hook the pull-end of an 8-ounce scale through the loop end of the spring and pull in the direction of travel.

14. UNIVERSAL CONTACT MECHANISM (TRANSFER TYPE) (TP104682)

Note: The universal transfer-contact mechanism is located to the left of the pullbar

contact mounting bracket and operates from the main bail. The upper contacts make as the bail reaches its highest position and as the bail travels toward its lowest position, the lower contacts make.

14.01 Contact Operating-lever: The contact operating-lever extension should be approximately midway between the No. 1 and No. 2 pullbars when the main bail is in its highest and lowest positions.

To Adjust: Position the universal contact assembly-bracket.

14.02 Universal Contact Assembly:

Note: Reference herein to inner and outer is explained as follows: (1) Inner: Nearest to the mounting bracket; (2) Outer: Farthest from the mounting bracket.

(a) The outer contact-spring stiffeners should be parallel to the side of the mounting bracket. (See Figure 28.)

To Adjust: Bend the outer stiffeners.

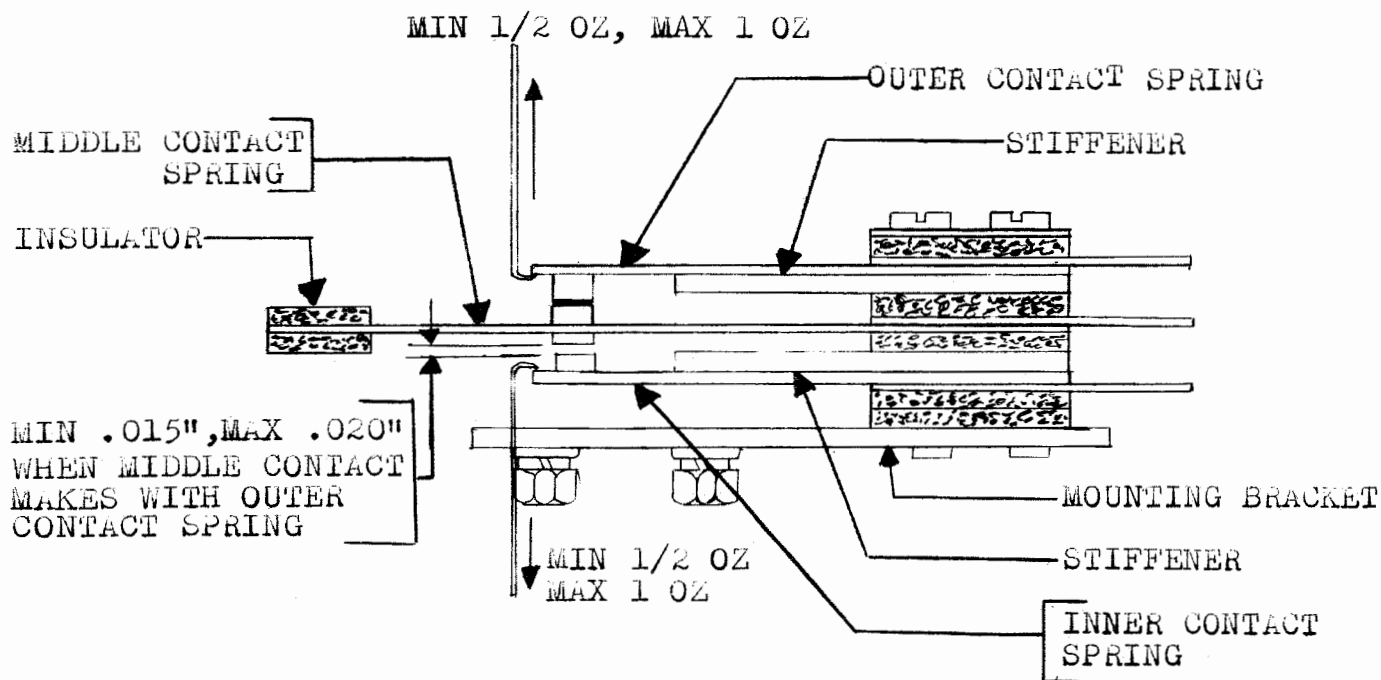

Figure 28



(b) It should require minimum 1/2 ounce, maximum 1 ounce to move each outer contact-spring away from its stiffener when the middle contact-spring is held clear of it. (See Figure 28.)

To Gauge: Hook the pull-end of an 8-ounce scale over the end of the contact spring and pull at right angles to the spring.

To Adjust: Bend the outer contact spring. Check that both sets of contacts make and break at approximately the same time when the middle contact-spring is operated and released.

(c) The middle contact-spring should be so tensioned that the outer contact spring is separated from its stiffener by not more than 0.006 inch when the contact operating-lever is held away from the middle contact spring. (See Figure 28 for location of parts.)

To Adjust: Bend the middle contact-spring.

(d) With the middle-spring contacts making contact with the outer-spring contacts and the inner contact-springs resting against their stiffeners, there should be a clearance of minimum 0.015 inch, maximum 0.020 inch between the middle-spring contacts and the inner-spring contacts. (See Figure 28.)

To Adjust: Bend the spring stiffeners and check that both sets of contacts on the middle and inner springs make and break at approximately the same time when the middle contact-spring is operated and released.

(e) It should require minimum 1/2 ounce, maximum 1 ounce to move each inner contact spring away from its stiffener. (See Figure 28.)

To Gauge: Apply the push-end of an 8-ounce scale to the end of each inner spring and push at right angles to the spring.

To Adjust: Bend the inner contact springs.

(f) When a pullbar having pullbar contacts is selected and the main shaft is rotated until the associated top pullbar contacts just close, there should be a clearance of minimum 0.025 inch, maximum 0.035 inch between the contact operating-lever and the insulator tip on the middle contact spring. If the unit has no pullbar contacts, this clearance should be 1/8 inch when the main bail is in its lowest position. (See Figure 27 and Figure 28 for location of parts.)

To Adjust: Position the contact operating-lever block, keeping its top surface horizontal.

(g) With the contact operating-lever coil spring unhooked from the lever and the lever held against the insulator tip of the middle contact spring, it should require minimum 4 ounces, maximum 6 ounces to pull the coil spring to position length. (See Figure 27.)

To Gauge: Hook the pull-end of an 8-ounce scale through the loop end of the spring and pull in the direction of travel.