

15 TYPING UNIT
REQUIREMENTS AND ADJUSTMENTS

CONTENTS	PAGE	CONTENTS	PAGE
1. GENERAL	3	Single-double line-feed detent	33
2. REQUIREMENTS AND ADJUSTMENTS	3	Single-double line-feed detent spring	33
Carriage-return and Spacing Mechanism		Mainshaft Mechanism	
Carriage-guide screws	47	Clutch-driven member.....	19
Carriage-return clutch	44	Clutch-throwout-lever spring	18
Carriage-return clutch spring....	46	Mainshaft clutch	17
Carriage-return function-lever spring	45	Mainshaft-clutch spring	18
Carriage-return latchbar	41	Selector cams	17
Carriage-return latchbar latch ...	41	Motor Unit	61
Carriage-return operating-lever spring	45	Platen Roll and Paper Mechanism	
Carriage-return operating-lever stop screw	45	Paper-chute spring	36
Carriage-return reset bar spring.	45	Paper-finger-shaft spring	36
Carriage-return spring	49	Paper-finger-shaft stop-arm.....	36
Carriage-support rollers	17	Paper guides.....	37
Dashpot-lever spring.....	46	Paper-spindle drag-spring	49
Dashpot-vent screw	59	Paper-straightener rod	36
Lock-bar latch.....	44	Paper-straightener-rod springs ..	37
Lock-bar-latch spring.....	44	Platen-friction assembly	49
Function-bail Mechanism		Platen shaft	33
Bail-cam-unit friction-clutch torque	58	Platen unit	27
FIGS, line-feed and LTRS function levers	28	Pressure-roller release cams....	35
Function-bail blade.....	29	Pressure-roller release-lever shafts.....	35
Function-bail spring.....	26	Pressure-roller release shaft....	35
Function-lever bail	23, 24	Pressure-roller release-shaft arm	35
Function-lever bail and blocking plate.....	23	Pressure-roller tension springs ..	35
Space-function-lever spring	29	Ribbon Mechanism	
Line-feed Mechanism		Left bearing plate	5
Line-feed check-lever spring.....	35	Ribbon-feed-pawl spring	4
Line-feed check screw.....	35	Ribbon-feed shaft	5
Line-feed check-screw head.....	33	Ribbon-feed-shaft detent	7
Line-feed detent lever spring.....	33	Ribbon-feed-shaft detent spring...	7
Line-feed pawl.....	33	Ribbon-lockout-bar detent spring .	15
Line-feed pawl spring	33	Ribbon-lockout lever	58, 57
Line-feed pushbar spring	33	Ribbon-oscillator lever	15, 56
Line-feed turnbuckle	33	Ribbon-oscillator-lever spring ...	15
		Ribbon-reverse-arm yield-spring .	10
		Ribbon-reverse-arm ribbon guide slot.....	9

CONTENTS	PAGE
Ribbon-reverse bail springs	13
Ribbon-reverse pawls	10
Ribbon-reverse pawl springs	10
Ribbon-reverse shaft collars	10
Ribbon-reverse shaft links	10
Ribbon-reverse shafts	10
Ribbon-shift-lever spring	15
Ribbon-spool cups	9
Ribbon-spool cups and ribbon-reverse-arm backstop	10
Ribbon-spool shafts	8
Right bearing plate	5
Vertical ribbon-feed-shaft bevel gears	7
Vertical ribbon-feed shafts	8
Vertical ribbon-feed-shaft springs	9
Vertical ribbon-feed-shaft spur gears	8
 Send-receive-break Mechanism	
Blank-function lever and No. 1 vane	52
Blank-function-lever spring	51
Intermediate lever	53
Intermediate-lever spring	53
Intermediate-lever toe	53
Send-receive mechanism plate	52
Send-receive reset-lever down-stop screw	53
Send-receive reset-lever lower adjusting-screw	53
Send-receive reset-lever upper adjusting-screw	53
Send-receive T-lever	51
Send-receive T-lever friction washer	49
Universal-function-lever spring ..	51
 Shift Mechanism	
FIGS stop screw	28
LTRS and FIGS pushbar springs ..	32
LTRS stop screw	28
Platen-balance spring	31
Platen-shift stop post	27
Shift detent	32
Shift-detent spring	32
Shift-link turnbuckle	31
Shift stop-post	31
Unshift-on-space cut-out lever ..	31
 Signal-bell Mechanism	
Signal-bell function-lever spring .	40
Signal-bell-hammer-arm extension	40
Signal-bell-hammer spring	38

CONTENTS	PAGE	
Signal-bell latch-bar	39	
Signal-bell latchbar latch	40	
Signal-bell operating-lever spring.	40	
Signal-bell reset-bar spring	40	
 Spacing Mechanism		
Blank printing and spacing cut-out function-lever spring	29	
Left margin	54	
Margin-bell	58	
Margin-bell hammer	38	
Margin-bell-hammer spring	38	
Margin-bell-pawl spring	15	
Rear-spacing-escapement pawl ...	37	
Right margin	55	
Right-margin adjusting-screw-arm spring	17	
Spacing-clutch torque	58	
Spacing-escapement-pawl spring ..	58	
Spacing rack	48	
Spacing-shaft gear	20	
Spacing-stop-lever	46	
Spacing-stop-lever spring	47	
 Transfer Mechanism		
Code-bar bellcranks	47	
Locking-function-lever spring	49	
Selector vanes	26	
Sixth-vane	26	
Sixth-vane detent spring	49	
Sixth-vane extension	32	
Sixth-vane extension spring	24	
 Typing Mechanism		
Alignment of type	60	
Printing-bail adjusting screw	21	
Printing-bail-shaft right bearing ..	20	
Printing-bail spring	27	
Pullbar bail	3, 4	
Pullbar-bail-plunger guide rollers	3, 17	
Pullbars	17, 21	
Pullbar springs	4	
Typebar backstop (floating type) ..	14	
Typebar backstop (rigid type)	13	
Typebar guide	49	
Typebar heels	60	
Typebars and pullbars	60	
Typebar toes	60	
 3. LIST OF FUNCTION LEVERS		62

1. GENERAL

1.01 This section contains the requirements and adjustments for the 15 typing unit. This section, associated sections, and the teletypewriter general requirements and adjustments section provide the complete adjusting procedures for the maintenance of the 15 typing unit.

1.02 This section is reissued to include the addendum and to bring the section generally up to date. The references formerly shown in this section have been deleted, as this information is now covered in the Numerical Index.

2. REQUIREMENTS AND ADJUSTMENTS

CAUTION: NEVER LAY THE TYPING UNIT ON ITS FRONT, AS THIS WOULD DAMAGE SOME OF THE PARTS.

Note 1: The typing unit should be removed from its base when making adjustments 2.01 to 2.129, inclusive. For 2.130 through 2.145 the typing unit is replaced unless otherwise stated.

TYPEBAR CARRIAGE ADJUSTMENTS (2.01 to 2.33.)

Note 2: Typebar carriage should be removed when making adjustments 2.01 to 2.40, inclusive. To do this, operate the manual-carriage-return lockbar and move the carriage to the extreme right position. Operate the dashpot lever to lock the carriage in this position. With the left hand, pull the draw strap forward under the upper track and grasp

it firmly to keep the drum from unwinding; with the right hand, unhook the draw strap from the carriage and hook it over the margin bell-hammer-arm stop-post while sliding the front end of the margin-bell spring to the left toward the casting. Operate the manual carriage-return lockbar, shift the right-hand margin-adjusting screw to the rear, and slide the carriage off to the right.

2.01 Pullbar Bail: The pullbar bail should be within 0.010 inch of being parallel to the stripper plate when the bail is held forward in a position adjacent to the stripper plate, and the bail plunger should be within 0.002 inch of being parallel to the flanged guide roller. Gauge by eye. See Figures 1 and 4.

To Adjust: Reposition the plunger guide roller bracket to the left or right until the bail is within 0.010 inch or touches the stripper plate at both ends when the bail is in its extreme forward position, and shift the bracket up or down until the plunger and the rollers are parallel.

2.02 Pullbar-bail-plunger Guide Rollers: The pullbar-bail-plunger guide rollers should rotate freely and the upper roller should clear the plunger by not more than 0.004 inch throughout the plunger travel. Gauge by eye.

To Adjust: Reposition the eccentric-mounting stud of the flanged roller. See Figure 1.

Note: Remove the typebar segment assembly for 2.03 and 2.04 by removing the typebar

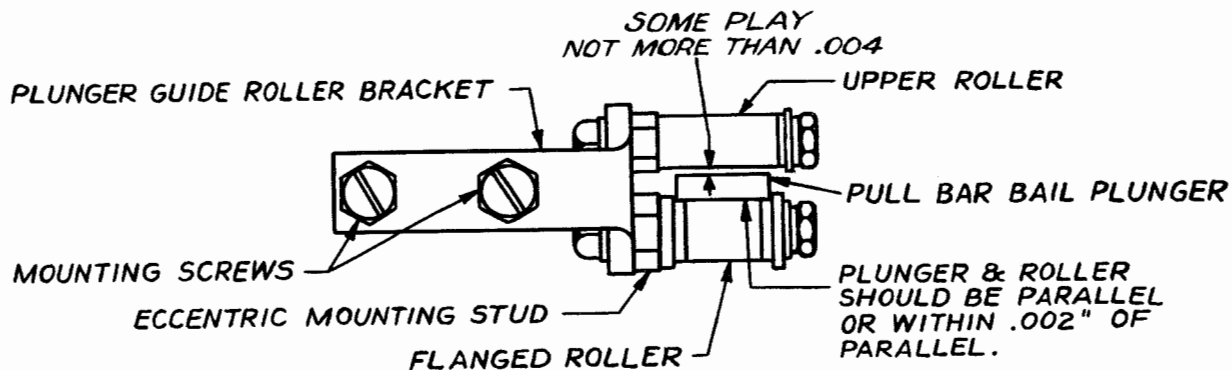

Figure 1

backstop, the ribbon carrier, and typebar-segment mounting-screws and with the pullbars held out of engagement with their guide using a string or wire under the bars, slide the assembly forward.

2.03 Pullbar Springs: The pullbar springs should have a tension of minimum 2-1/2 ounces, maximum 3-1/2 ounces. See Figure 2.

2.04 Ribbon-feed-pawl Spring: The ribbon-feed-pawl spring should have a tension of minimum 2-1/4 ounces, maximum 3-1/4 ounces when the pullbar bail is in its extreme rear position and the type carriage is held in its normal position. See Figure 3.

Note: Reassemble the typebar-segment assembly, the backstop and ribbon carrier, being careful to get the ribbon lockout bar, the

detent spring, and the ribbon oscillator lever in their proper slots.

Note: The bellcrank-mounting-plate assembly should be removed when making adjustments 2.05 to 2.30, inclusive. Be careful not to bend the upper ends of bellcranks.

2.05 Pullbar Bail: The pullbar bail should clear the hump on the pullbars by minimum 0.008 inch, maximum 0.020 inch, when the pullbar play is taken up to make the clearance a minimum. See Figure 4. For the Blank pullbar, if present, check the clearance with the codebars shifted to the left. For all other pullbars, check the clearance with the codebars shifted to the right.

To Adjust: Reposition the pullbar guide.

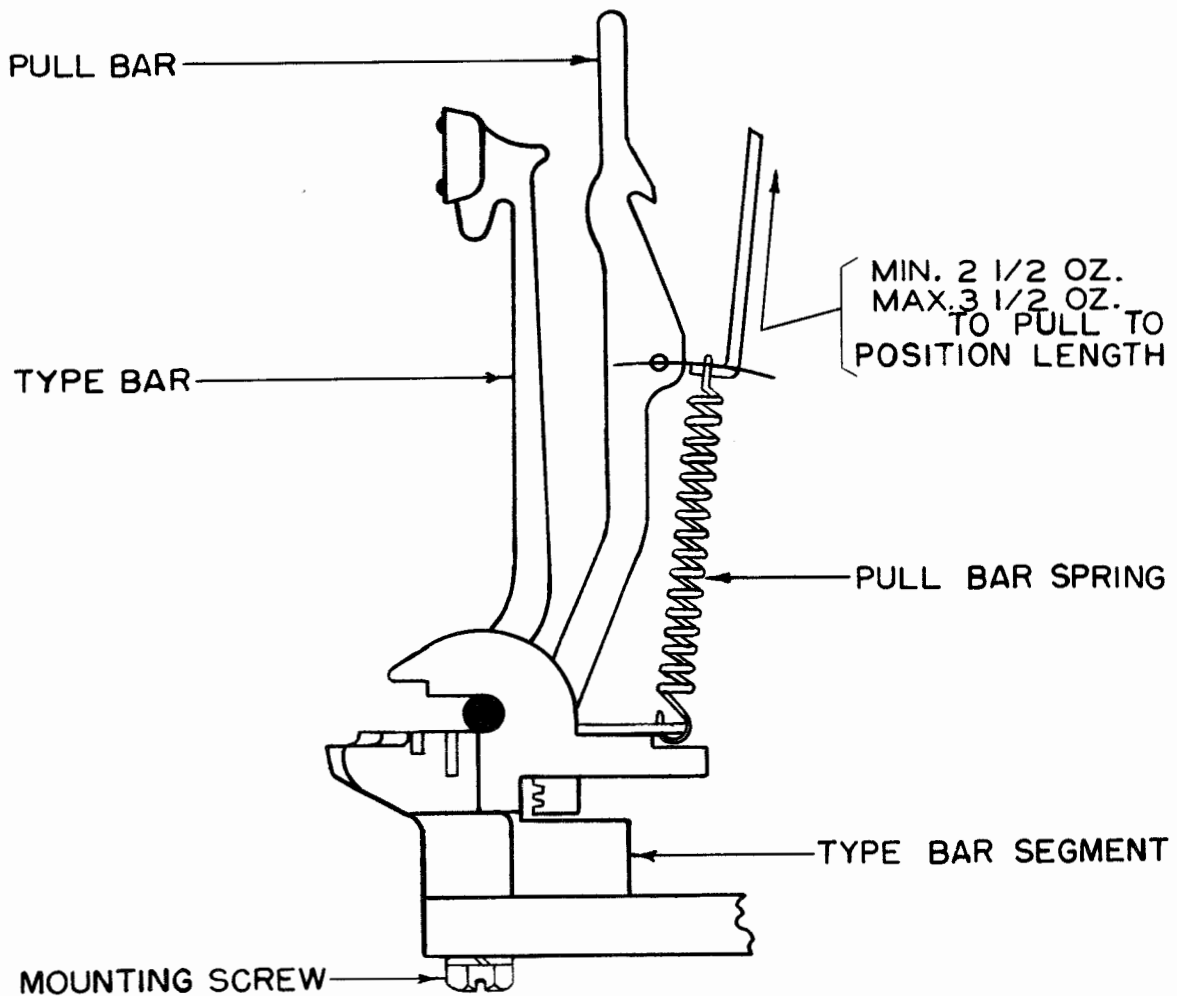

Figure 2

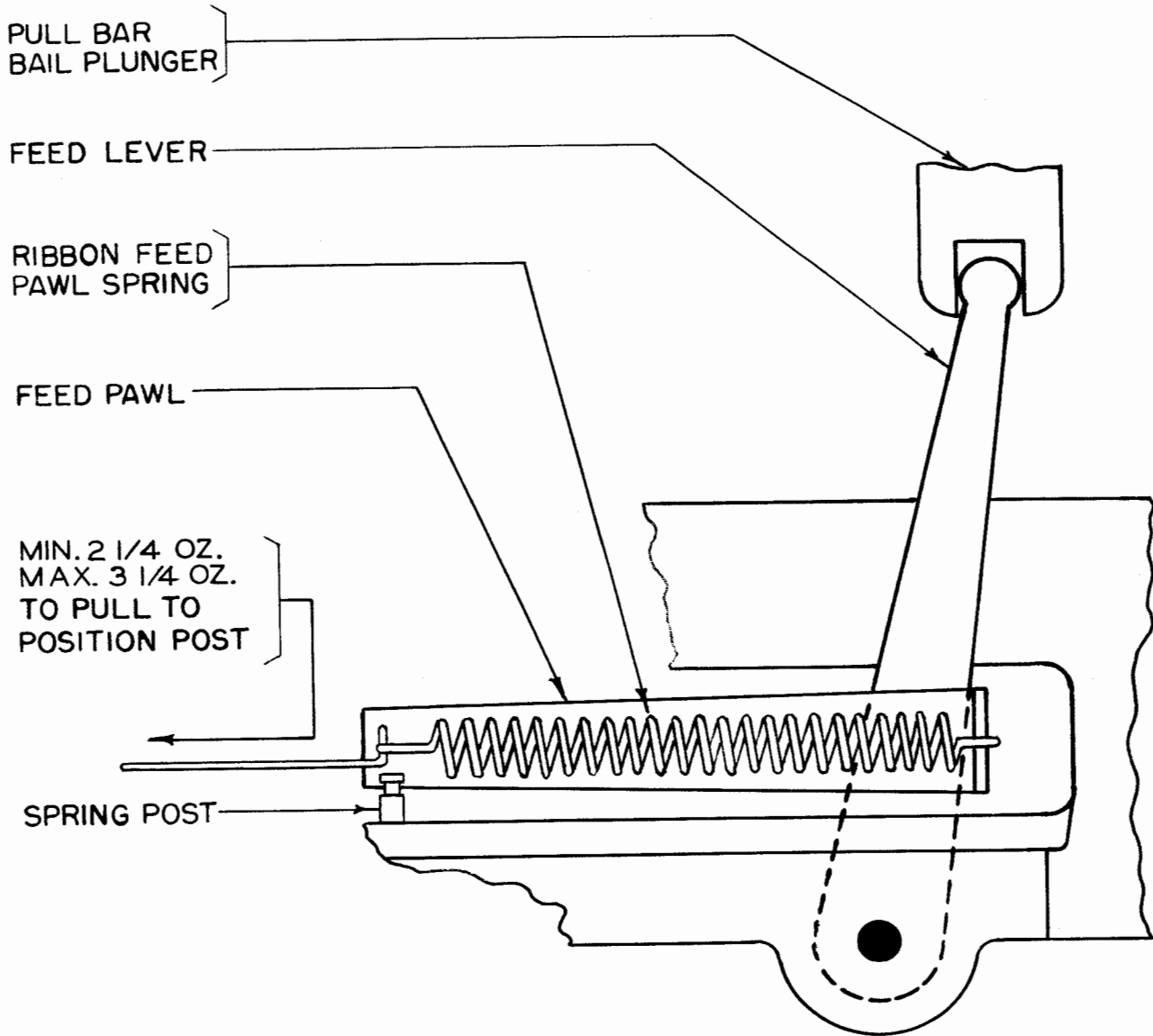

Figure 3

2.06 Ribbon-feed Shaft: The ribbon-feed shaft ends should be flush with, or extend not more than 0.015 inch beyond the inner ends of the teeth on the engaged vertical-feed-shaft gear when the ribbon-feed shaft is in its extreme right and left positions. Gauge by eye. See Figures 5 and 6.

To Adjust: Move both ribbon-spool brackets up as far as the elongated holes will permit and tighten the bracket-mounting screws with the bracket vertical (at right angles to the casting); place the ribbon-feed shaft in the left position and loosen the

ribbon-feed-shaft right-bearing-plate clamp nuts; holding the left vertical-feed shaft gear in engagement with the ribbon-feed shaft gear, reposition the **RIGHT BEARING PLATE** and tighten the bearing-plate clamp nuts. Move the ribbon-feed shaft to the right position and position the **LEFT BEARING PLATE** in the same manner.

Note: The lateral movement of the ribbon-feed shaft (movement from one detented position to the other) should measure at least 3/16 inch. If necessary, refine the ribbon-feed-shaft bearing-plates adjustments.

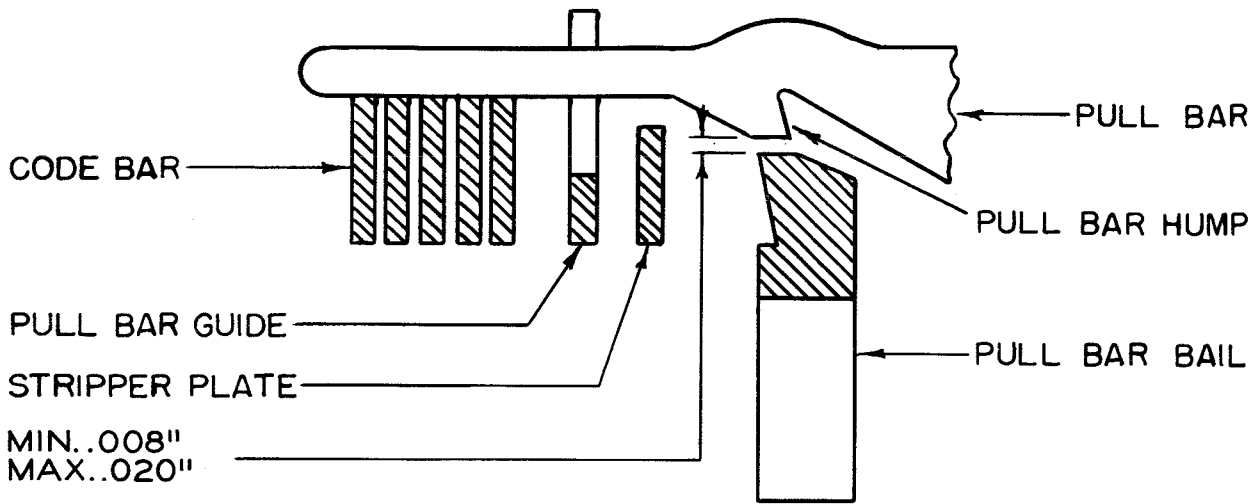

Figure 4

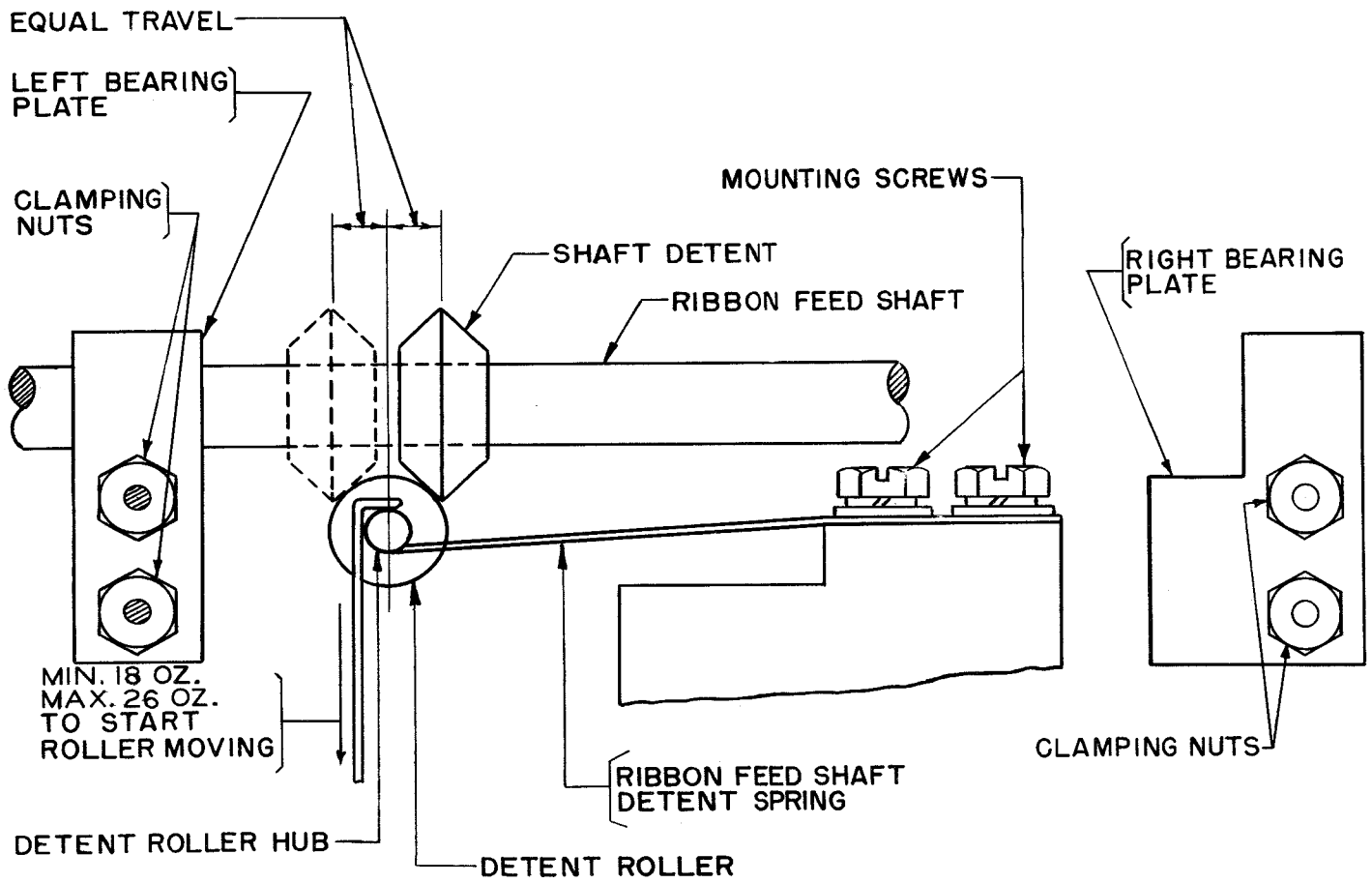

Figure 5

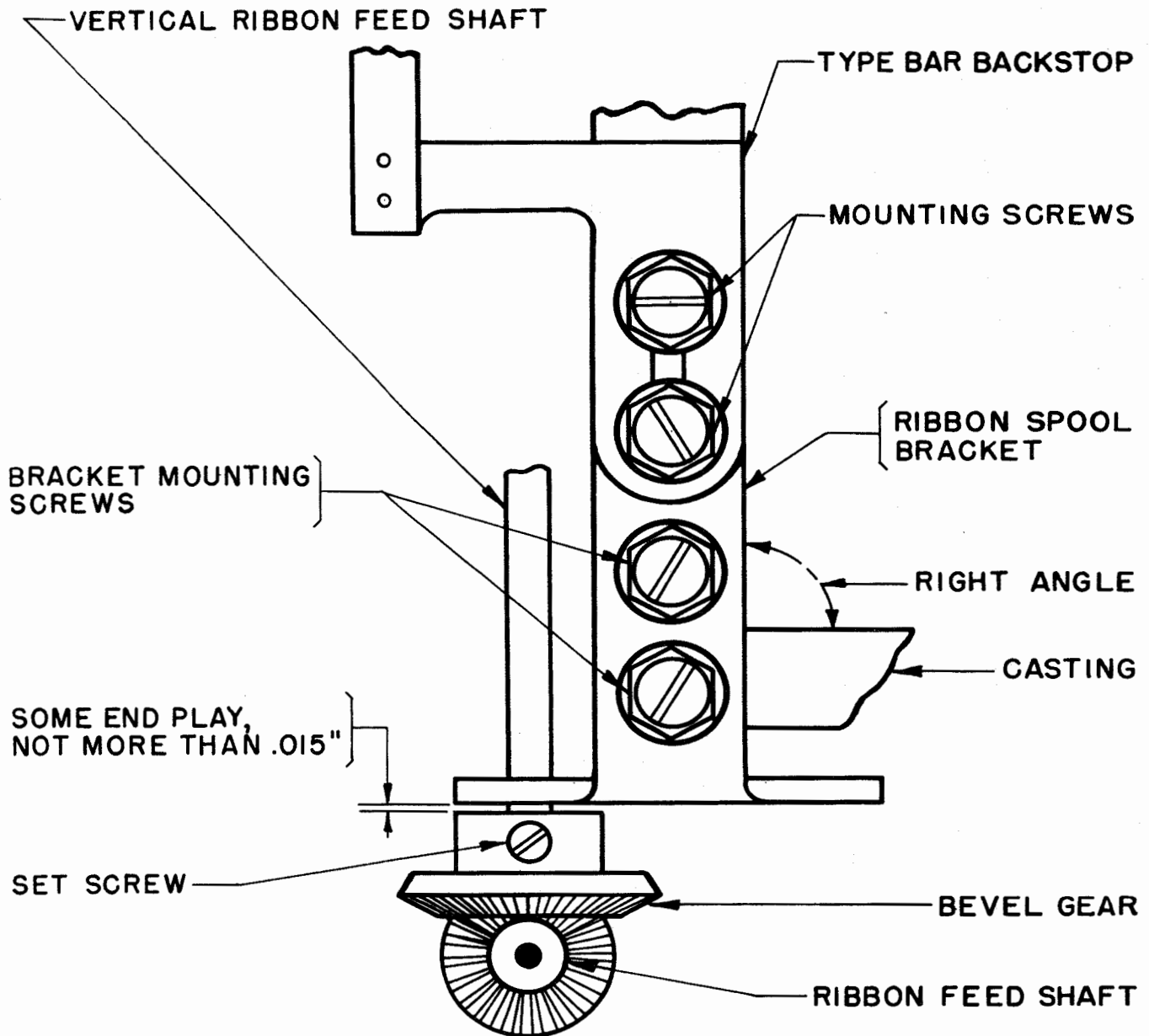

Figure 6

2.07 Ribbon-feed-shaft Detent: The ribbon-feed-shaft detent should travel equally on either side of its detent roller when the shaft is moved from the extreme left to the extreme right or vice versa. Gauge by eye. See Figure 5.

To Adjust: Reposition the detent spring. When tightening the detent spring mounting screws make sure the midplane of the roller passes approximately through the shaft centerline.

2.08 Ribbon-feed-shaft Detent Spring: The ribbon-feed-shaft detent spring should have a tension of minimum 18 ounces, maximum 26 ounces, when the ribbon-feed shaft is in left position and when the shaft is in the right position. See Figure 5.

To Adjust Tension: Bend the spring, and recheck 2.07.

2.09 Vertical Ribbon-feed-shaft Bevel Gears: The vertical ribbon-feed-shaft bevel gears

should be flush with the lower end of the shafts as gauged by eye. See Figure 6.

To Adjust; Reposition the bevel gears making sure that the set screws bear against the flats on the shafts when tightened.

2.10 Vertical Ribbon-feed Shafts: The vertical ribbon-feed shafts should be vertical and should have endplay not to exceed 0.015 inch, gauged by eye and feel, when the bevel gears are in engagement with the associated ribbon-feed-shaft gear. See Figure 6.

Note: When checking, take up the ribbon-feed-shaft bearing play in a direction to make the endplay of the vertical shaft a maximum.

To Adjust: Reposition the ribbon-spool bracket.

2.11 Ribbon-spool Shafts: The ribbon-spool shafts should have endplay, not to exceed 0.006 inch. Gauge by eye and feel. See Figure 7.

To Adjust: Reposition the ribbon-spool-shaft spur gears, making sure the set-screws bear against the flats on the shafts when tightened.

2.12 Vertical Ribbon-feed-shaft Spur Gears: The vertical ribbon-feed-shaft spur gears should line up with the ribbon-spool-shaft spur gears. Gauge by eye. See Figure 7.

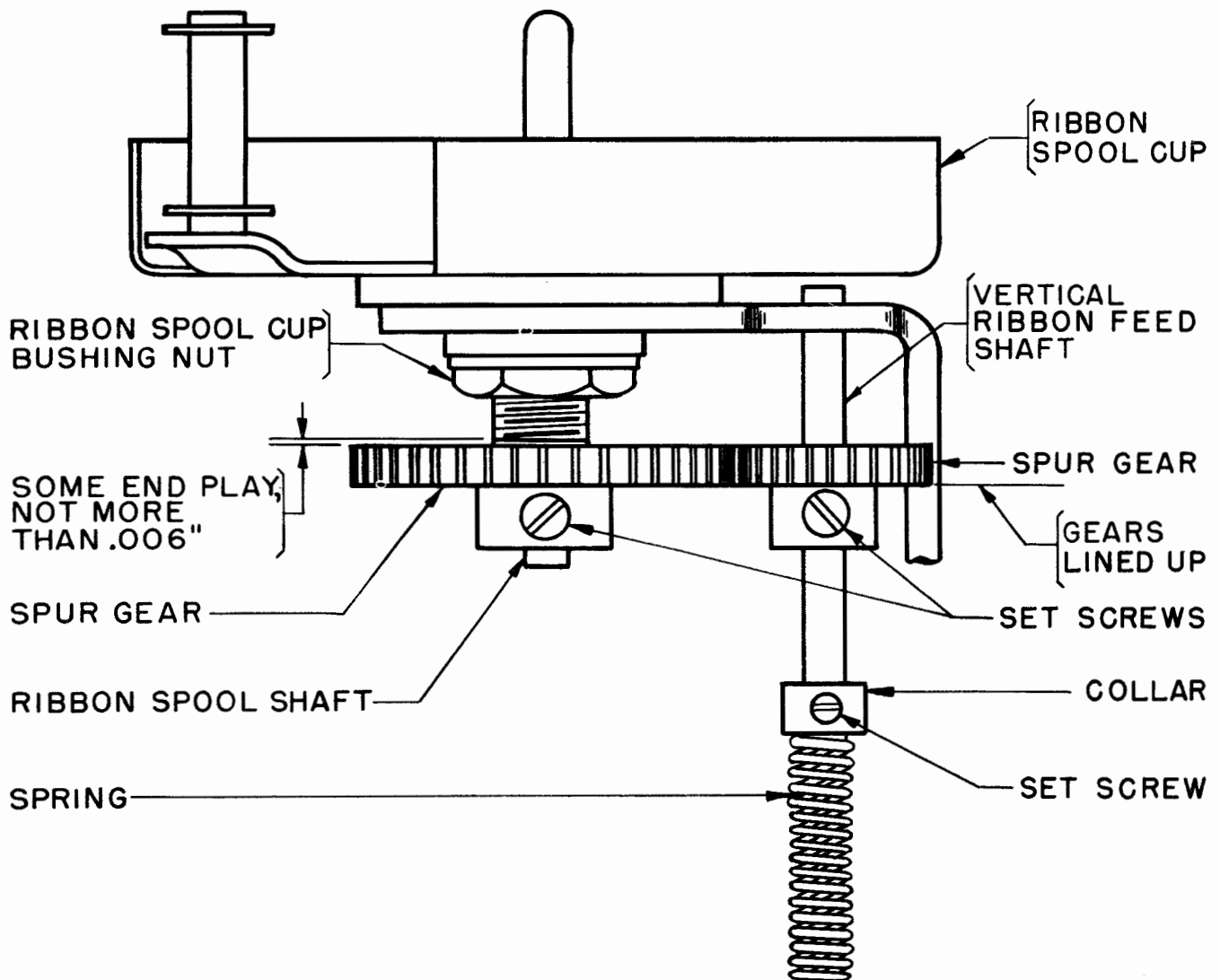

Figure 7

To Adjust: Reposition the vertical feed shaft spur gears, making sure the set-screws bear against the flats on the shaft when tightened.

Note: For units equipped with yield mechanism use requirement 2.19 instead of 2.13.

2.13 **Ribbon-spool Cups:** The ribbon-spool cups should be positioned so that (1) their ribbon roller-bearing pins are minimum $3/4$ inch, maximum $7/8$ inch, in front of a line through the ribbon-spool-shaft centers, and (2) there is no bind between the gears on the ribbon-spool shaft and the vertical ribbon-feed shaft. Gauge by eye and feel. See Figure 8.

To Adjust: Reposition the ribbon-spool cups taking up the play between the cup bushings and the brackets to make the play between the gears a maximum. See Figure 7.

2.14 **Vertical Ribbon-feed-shaft Springs** should exert a pressure of minimum 2 ounces, maximum $4-1/2$ ounces, when the associated horizontal and vertical ribbon-feed-shaft bevel gears are disengaged. See Figure 8.

To Adjust: Reposition the adjusting collar on the vertical feed shaft. See Figure 7.

2.15 **Ribbon-reverse-arm Ribbon Guide Slot** should be minimum 0.025 inch, maximum

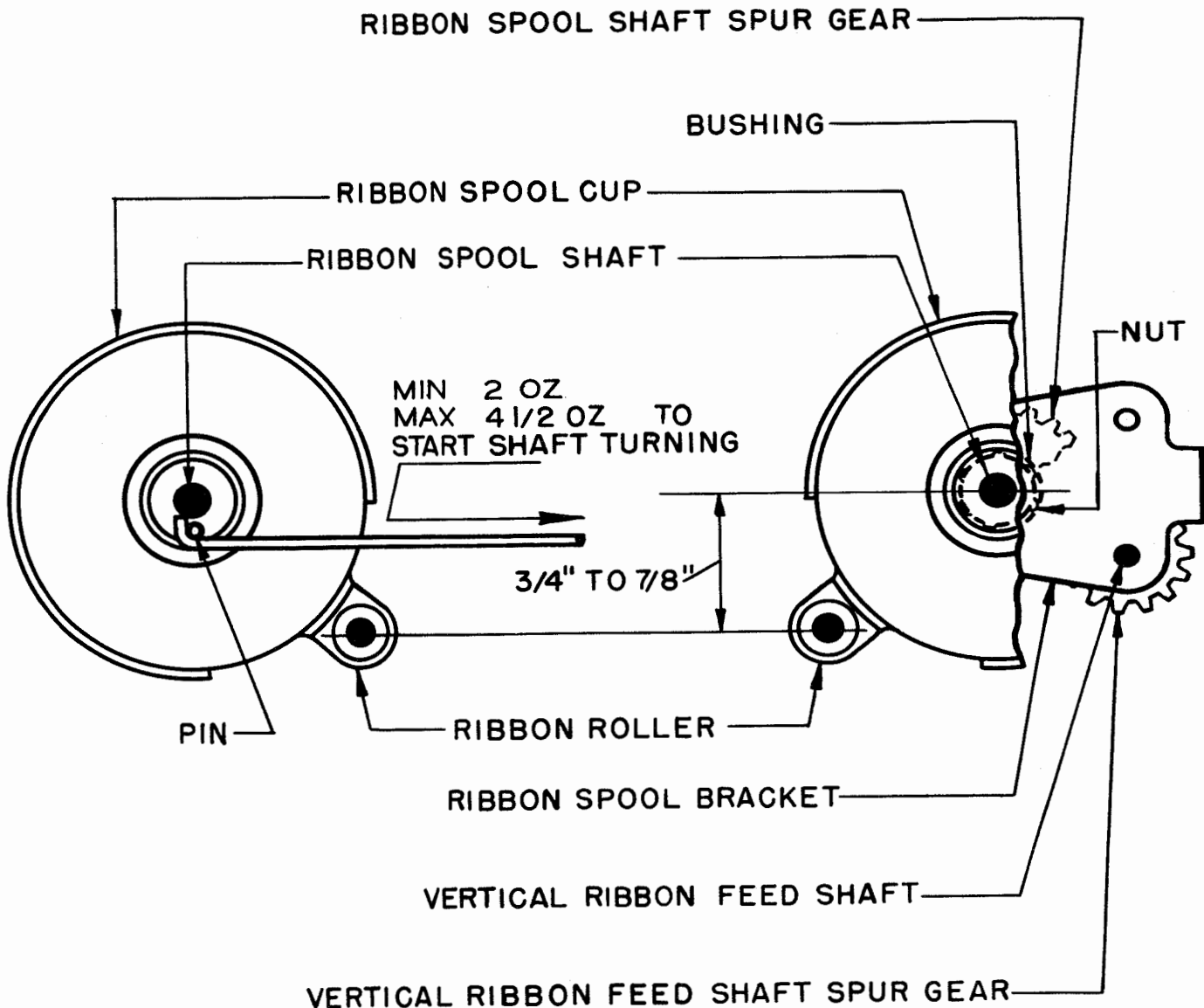

Figure 8

0.035 inch wide and the straight upright piece shall clear the angled arm by minimum 0.010 inch, maximum 0.020 inch. Gauge by eye. See Figure 9.

To Adjust: Bend the upright ends of the ribbon-reverse arms.

2.16 Ribbon-reverse Shafts should rotate freely and clear the ribbon-spool cups by minimum 0.040 inch, maximum 0.060 inch when the associated ribbon-reverse arm is held against the ribbon-spool bracket. See Figure 9.

To Adjust typing units not equipped with ribbon-yield mechanism, loosen the setscrew of the left ribbon-reverse arm, and if necessary, the setscrews of the collars and the link of the left ribbon-reverse shaft. Position the shaft while holding the ribbon-reverse arm up against the ribbon-spool bracket and then tighten the ribbon-reverse-arm setscrew. Adjust the right ribbon-reverse shaft in the same manner. See Figure 9.

To Adjust typing units equipped with the ribbon-yield mechanism, loosen the setscrew of the spring block on the left ribbon-reverse shaft, and, if necessary, the setscrews of the ribbon-reverse-shaft collar and link. Position the shaft while holding the ribbon-reverse arm against the ribbon-spool bracket and the spring block up against the reverse arm. Then tighten the spring-block setscrew. Adjust the right ribbon-reverse shaft in the same manner. See Figure 10.

2.17 Ribbon-reverse Shafts: (Applies only to units not equipped with yield mechanism): The ribbon-reverse shafts should have some endplay, minimum 0.002 inch, maximum 0.010 inch, when the ribbon-reverse arm is held against the ribbon-spool bracket. See Figure 9.

To Adjust: Reposition the ribbon-reverse-shaft collars, making sure that there will be minimum 1/4 inch, maximum 3/8 inch between the center of the setscrew and the ribbon-spool-bracket edge when tightening the setscrews.

2.18 Ribbon-reverse Pawls should clear the ribbon-reverse bail by minimum 0.015 inch, maximum 0.050 inch when the pullbar bail is in its extreme rear position and the associated ribbon-reverse arm is against the hub of the ribbon-spool bushing. See Figure 11.

Note: Take up the play in the bail to make the clearance a minimum when checking the 0.015 inch clearance, and a maximum when checking the 0.050 inch clearance.

To Adjust: Position the ribbon-reverse-shaft links by means of their setscrews, making sure that the ribbon-reverse-pawl links do not bind at their shoulder screws and that the right ribbon-reverse-shaft link clamping screw does not interfere with the screw that anchors the ribbon-feed ratchet-friction spring to the carriage casting.

2.19 Ribbon-spool Cups and Ribbon-reverse-arm Backstop (Applies only to units equipped with yield mechanism.) The centers of the ribbon rollers should be minimum 3/4 inch, maximum 7/8 inch in front of a line throughout the centers of the ribbon-spool shafts. With the ribbon-reverse arms held against their backstops, approximately 3/4 of the tooth on each ribbon reverse pawl should be in a position to be engaged by the ribbon-reverse bail. There should be no bind between the ribbon-spool-shaft spur gears and the vertical ribbon-feed-shaft spur gears at any point in their engagement. See Figures 8, 10, and 11.

To Adjust: Position the ribbon-spool cups and the ribbon-reverse-arm backstops by means of the nuts on the ribbon-spool-cup bushings. When tightening the nuts, take up the play between the ribbon-spool-cup bushings and the ribbon-spool brackets in a direction to make the play between the spur gears a maximum. See Figure 7.

2.20 Ribbon-reverse-arm Yield-spring tension should be minimum 1-1/2 ounces, maximum 4-1/2 ounces to start the ribbon-reverse arm moving, with the ribbon-reverse bail so positioned that it will block the full travel of the ribbon-reverse arm, and with the ribbon-reverse pawl resting against the ribbon-reverse bail apply the push end of the scale, held at a right angle to the ribbon-reverse arm, to the upper end of one of the prongs. See Figure 10.

To Adjust: Remove the spring and bend.

2.21 Ribbon-reverse-pawl Springs should have a tension of minimum 1 ounce, maximum 2 ounces when the associated ribbon-feed-shaft bevel gears are engaged, the pullbar is in its extreme forward position, and the carriage is held so the ribbon spool cups are down. See Figure 11.

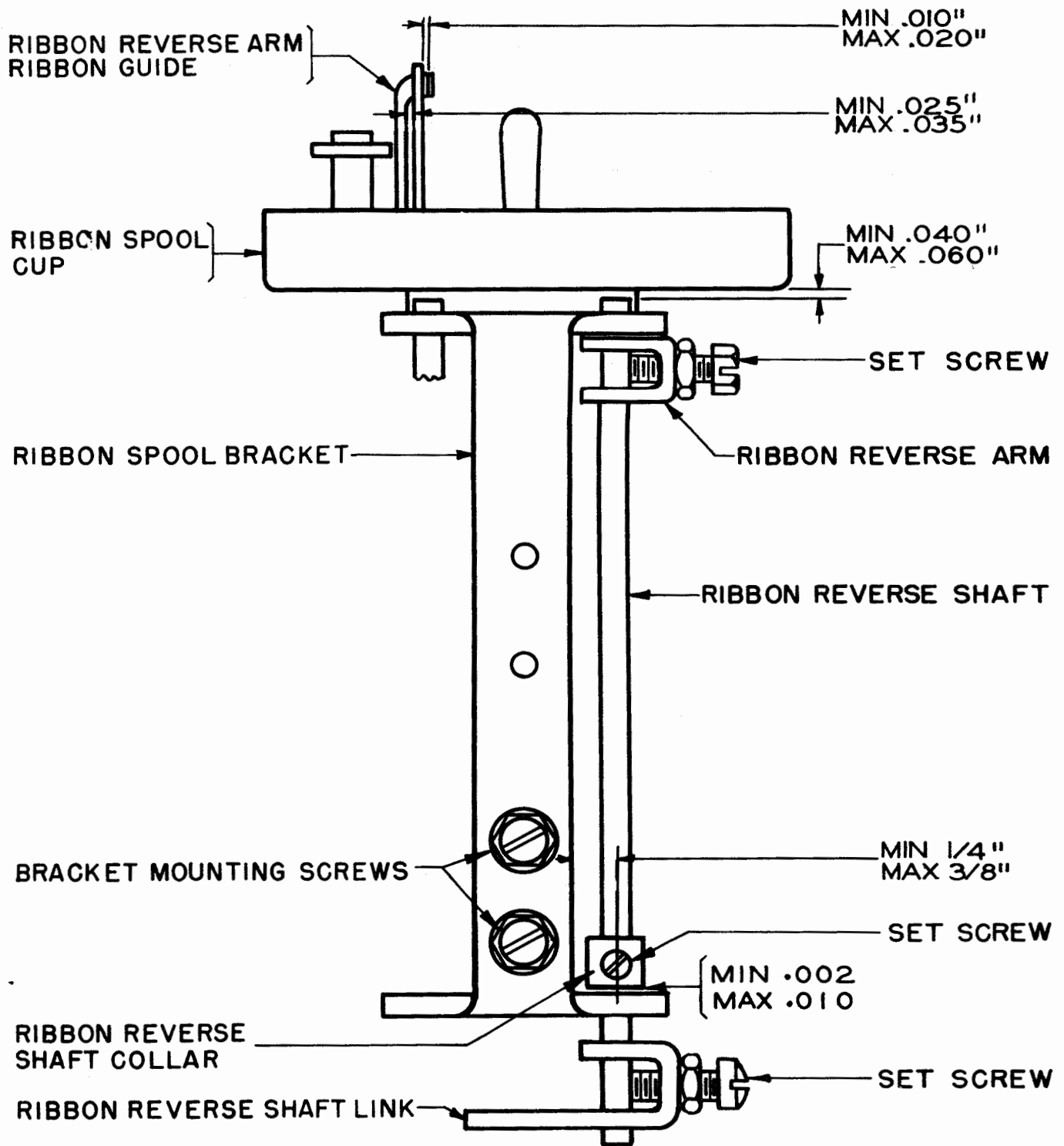
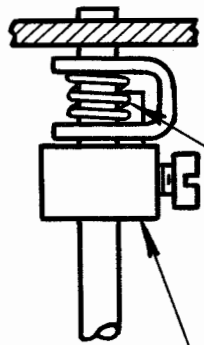

Figure 9

MIN. 1 1/2 OZ.
MAX. 4 1/2 OZ.
TO START ARM MOVING

RIBBON REVERSE ARM

RIBBON SPOOL CUP



RIBBON REVERSE
SPRING BLOCK

RIBBON SPOOL
BRACKET

BRACKET MOUNTING
SCREWS

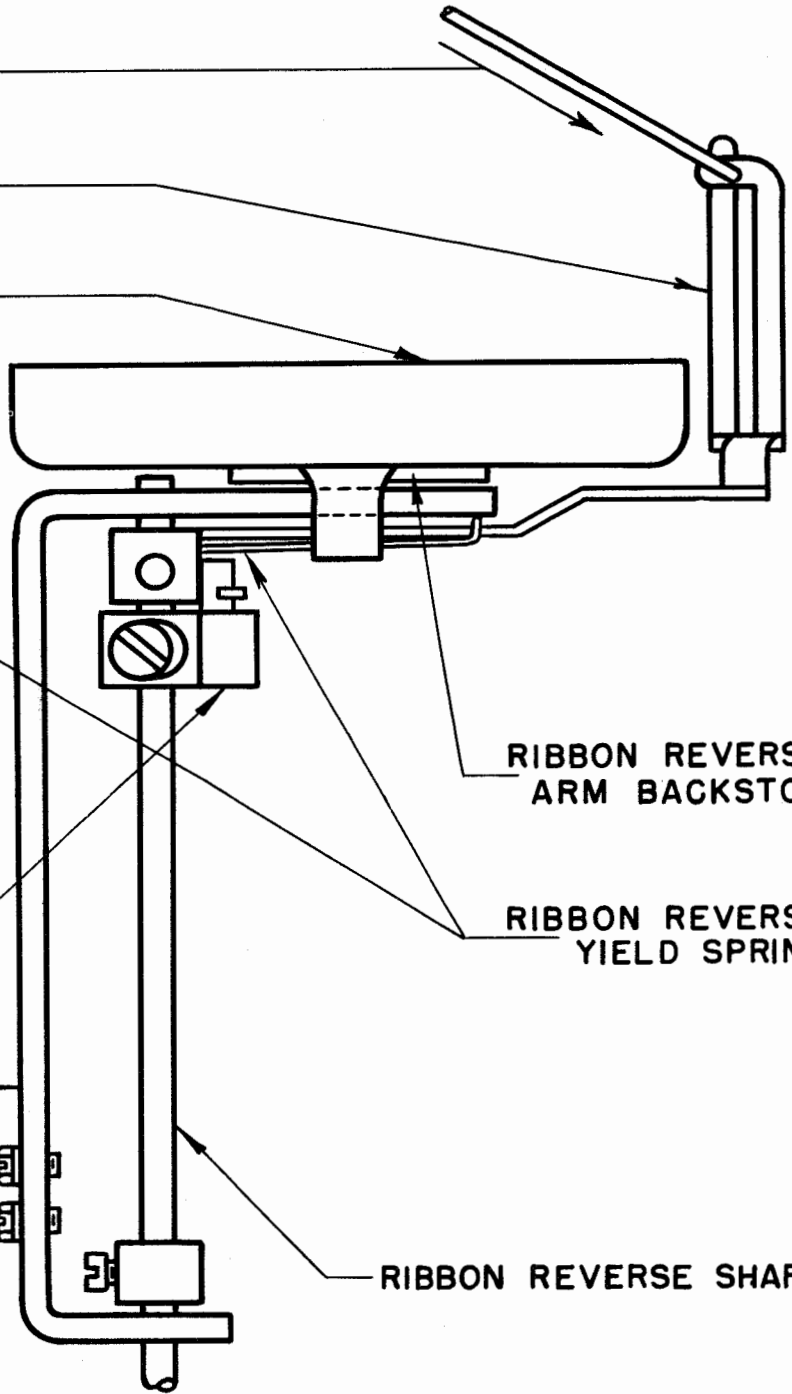

RIBBON REVERSE
ARM BACKSTOP

RIBBON REVERSE
YIELD SPRING

RIBBON REVERSE SHAFT

Figure 10

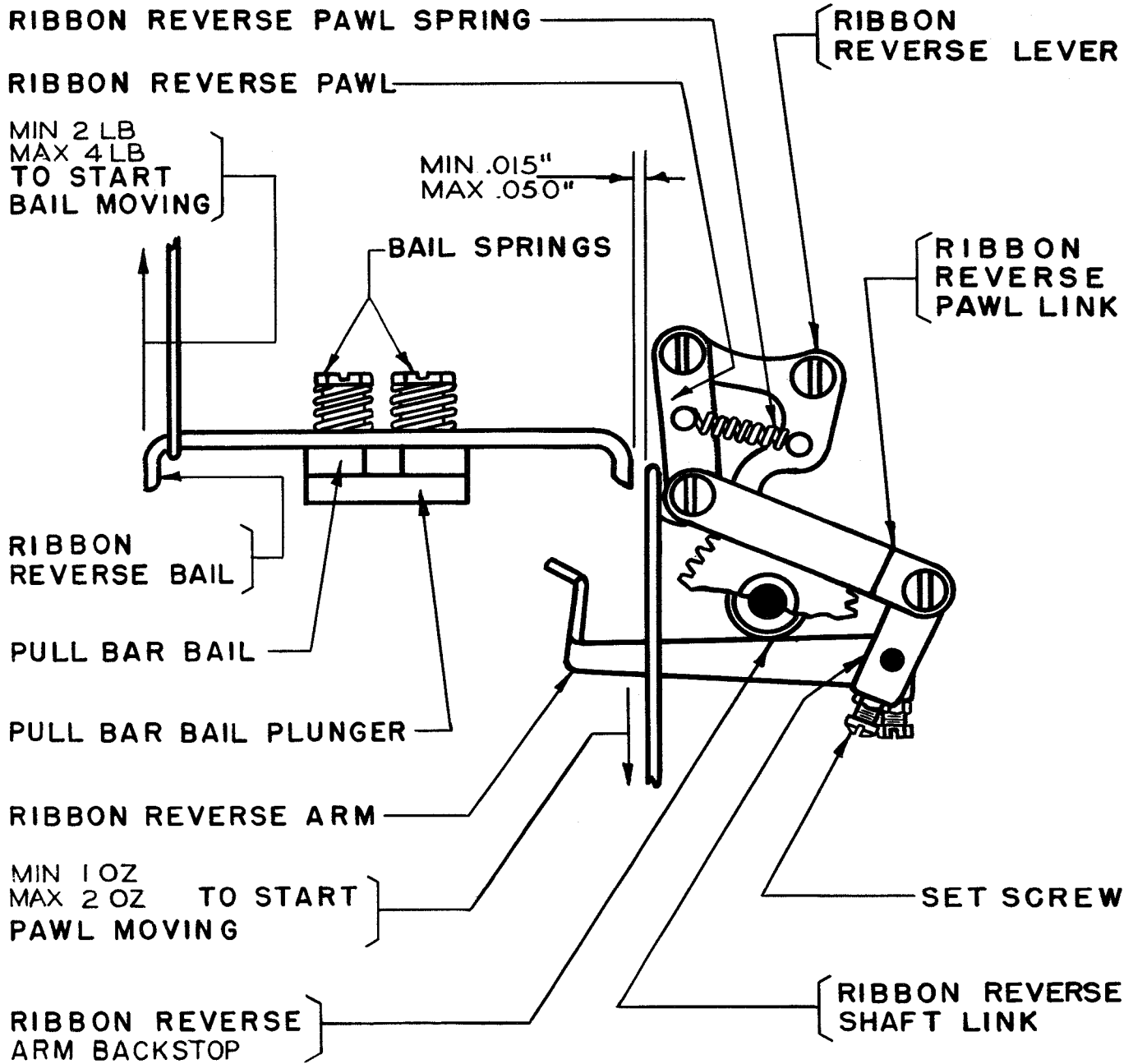

Figure 11

2.22 Ribbon-reverse-bail Springs should exert a pressure of minimum 2 pounds, maximum 4 pounds when the carriage is held so that the ribbon-spool cups are down. See Figure 11.

Note: Gauge the right and left springs in turn by applying a gauge at the right and left end of bail in turn.

2.23 Typebar Backstop (Rigid Type) should clear the center and two end pullbars by

at least 0.010 inch when the typebars are held in the guide and the pullbar bail is in its extreme rear position; the end typebars should rest against the rear edge of the backstop and be within 0.010 inch of touching the front edge. Gauge by eye. See Figure 12.

To Adjust: Reposition the typebar backstop.

Note 1: When meeting the clearance requirement between the backstop and the pullbars,

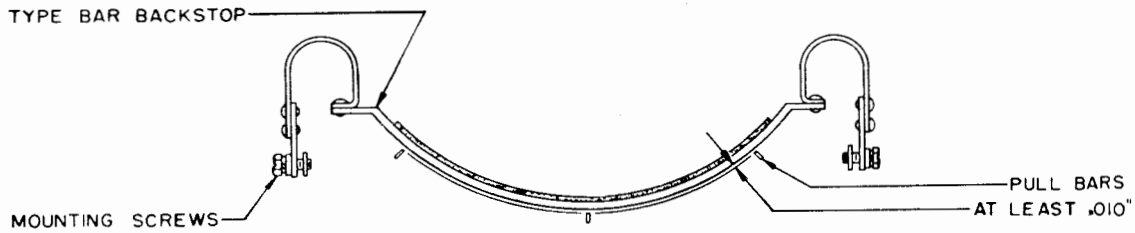

Figure 12

the backstop should be positioned as low as possible in an attempt to eliminate any interference between adjacent typebar assemblies at the pallet ends which would be likely to cause light printing.

Note 2: When making the preceding adjustment, it is desired that the end typebars rest against the backstop strip along the entire width of the strip. It is permissible, however, to allow a clearance of not more than 0.010 inch between the front edge of the backstop strip and the typebars.

2.24 Typebar Backstop (Floating Type) should meet the following requirements:

(a) The right end of the typebar backstop should overlap the outside end of the formed projection of the supporting spring by $1/64$ inch to $1/16$ inch, as gauged by eye, when the play of the backstop is taken up toward the left. The left end of the typebar backstop should be checked in a similar manner when the play in the backstop is taken up toward the right. See Figure 13.

To Adjust: Form the right-hand or left-hand supporting spring as necessary by bending, keeping its projection in a horizontal plane.

(b) There should be at least 0.010-inch clearance between the undersurface of the backstop and the closest pullbar when the play of the backstop is taken up to the left and the left-end typebar and center typebar are raised and held against the platen. This check should be repeated with the play in the backstop taken up toward the right and with the right-end typebar and center typebar held against the platen.

To Adjust: With the pullbar bail in its extreme rear position and with the backstop located at the approximate center, position the typebar backstop brackets upward or downward by means of the elongated holes.

(c) The clearance between the codebars and any pullbars should be at least 0.010 inch when the printing bail is in its rearmost (stop) position and the play in the typebar backstop is taken up toward the left and then toward the right.

To Check: Position the typebar carriage in its extreme right and left positions and take up the play of the pullbars in a direction to make the clearance a minimum.

To Adjust: Refine the adjustments in (a) (To Adjust) and (b) (To Adjust).

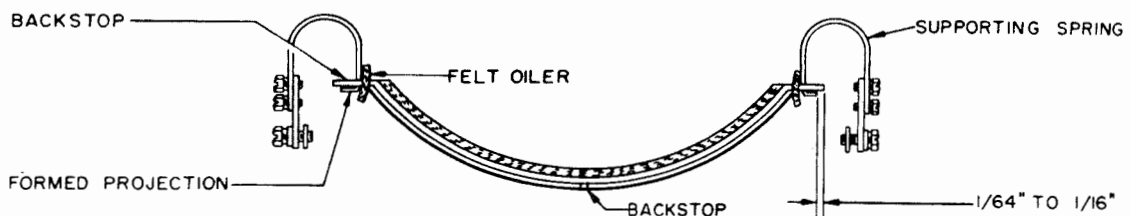

Figure 13

2.25 Ribbon-oscillator Lever should be free in its slot when its spring is unhooked. Gauge by feel. See Figure 14.

To Adjust: Reposition the ribbon-shift-lever bracket. See Figure 15.

2.26 Ribbon-oscillator-lever Spring should have a tension of minimum 2-1/2 ounces, maximum 3-1/2 ounces, when the ribbon-shift-lever spring is removed. See Figure 14.

2.27 Ribbon-shift-lever Spring should have a tension of minimum 1 pound, maximum 1-3/4 pounds, when the ribbon-oscillator spring is unhooked from the lever. See Figure 14.

2.28 Margin-bell-pawl Spring should have a tension of minimum 1/2 ounce, maximum 1-1/2 ounces. See Figure 15.

2.29 Ribbon-lockout-bar Detent Spring on typing units equipped with nonadjustable ribbon-lockout bar, should have a tension of minimum 16 ounces, maximum 32 ounces, when the ribbon-oscillator extension is held clear of the lockout bar and the latter is pushed in. See Figure 16.

To Adjust: Bend the detent spring.

2.30 Ribbon-lockout-bar Detent Spring on units equipped with an adjustable ribbon-lockout bar, should have a tension of minimum 1-1/4

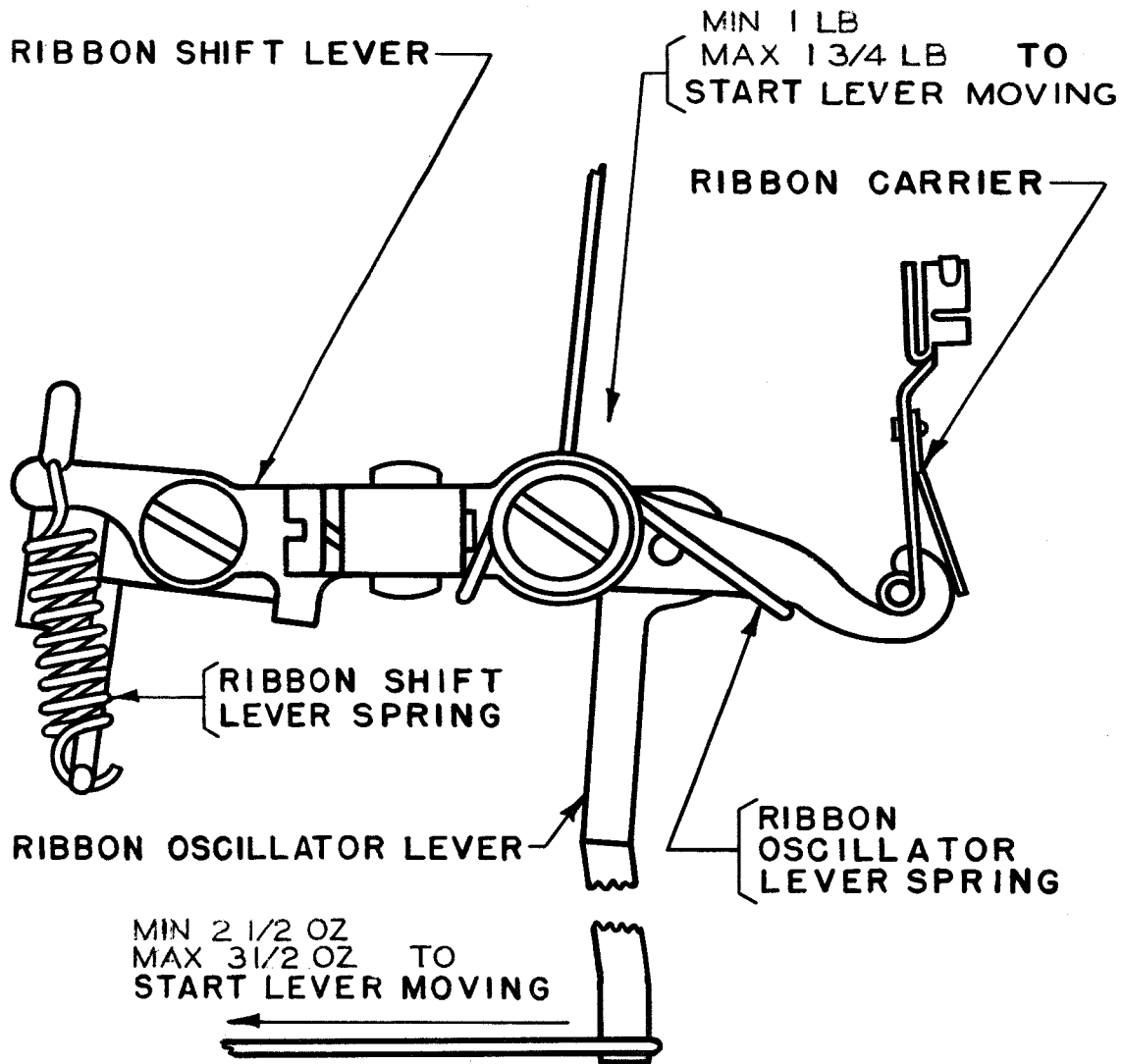

Figure 14

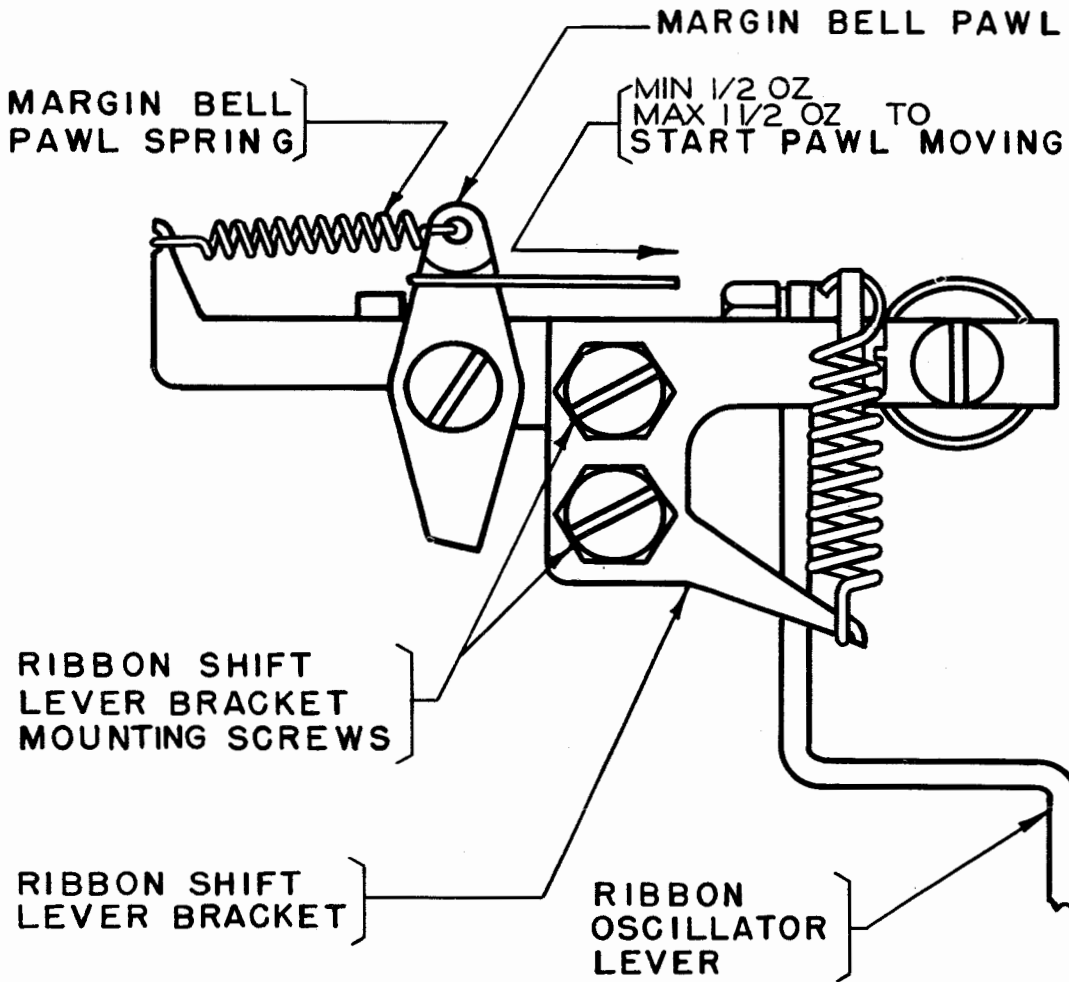

Figure 15

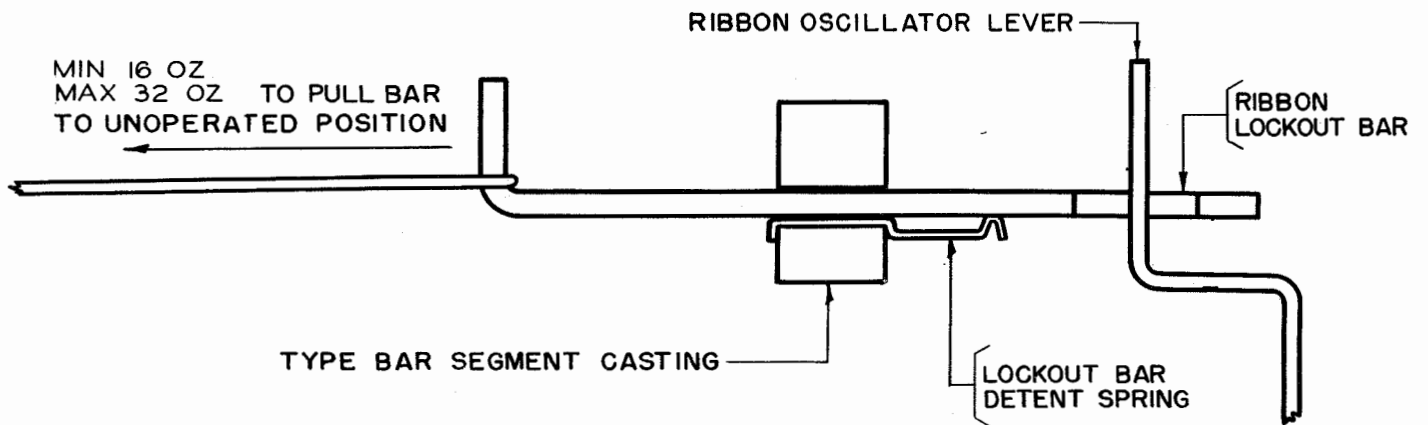

Figure 16

pounds, maximum 6-1/2 pounds as the detent spring disengages from the lockout-bar notch when the lockout bar is in its unoperated position (extreme right). See Figure 17.

To Adjust: Bend the detent spring.

Note: Reassemble the bellcrank assembly on the typebar carriage. First position the eccentric bushings which mount the bellcranks to the mounting plate so that the bellcranks are in their lowest position with respect to the codebars. Insert the right mounting screw and tighten it until the bellcrank mounting plate is held friction tight. Then rotate the mounting plate clockwise, engaging the bellcranks with their respective codebars, insert the left mounting screw and tighten both screws. See Figure 18.

2.31 Pullbars: On units equipped with the three-piece pullbar-spring bracket, the extreme right-end and left-end pullbars and the fourth from the right-end and the third from the left-end (second from left-end when the blank pullbar is not furnished) should have play, not to exceed 0.004 inch, between the spring bracket and the pullbar when the pullbar bail is in its extreme rear position and the corresponding typebar is raised to the typebar guide. See Figure 19.

To Adjust: Reposition the right and left sections of the pullbar-spring bracket.

Note: If the pullbars between those mentioned above bind against the spring bracket when

their typebars are moved to the typebar guide by hand, readjust the spring bracket so that all these pullbars are free and the end pullbar and at least one other pullbar of each group have 0.004 inch play.

2.32 Right-margin Adjusting-screw-arm Spring should have a tension of minimum 2 pounds, maximum 7 pounds. See Figure 20.

To Adjust: Bend the detent spring.

2.33 Pullbar-bail Plunger Roller which engages the printing-bail blades and the carriage-support rollers should rotate freely without perceptible endplay.

To Adjust the Rollers: Loosen the lock-nuts and position bearing cone or bearing nut. Be careful not to allow balls to fall out. See Figure 24.

MAINSHAFT MECHANISM (2.34 to 2.38).

Note: Place the typing unit on its right side.

2.34 Selector Cams should line up with their respective selector levers as gauged by eye.

To Adjust: Reposition the mainshaft in its bearings.

2.35 Mainshaft Clutch: Teeth of members of mainshaft clutch should clear each other by minimum 0.010 inch, maximum 0.020 inch

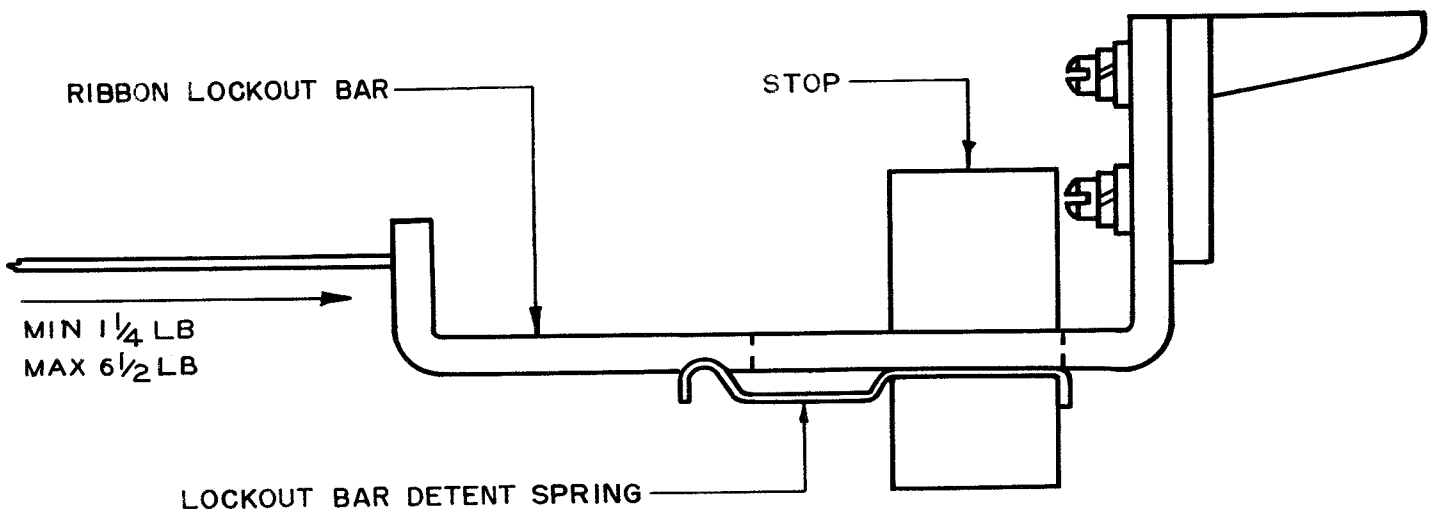

Figure 17

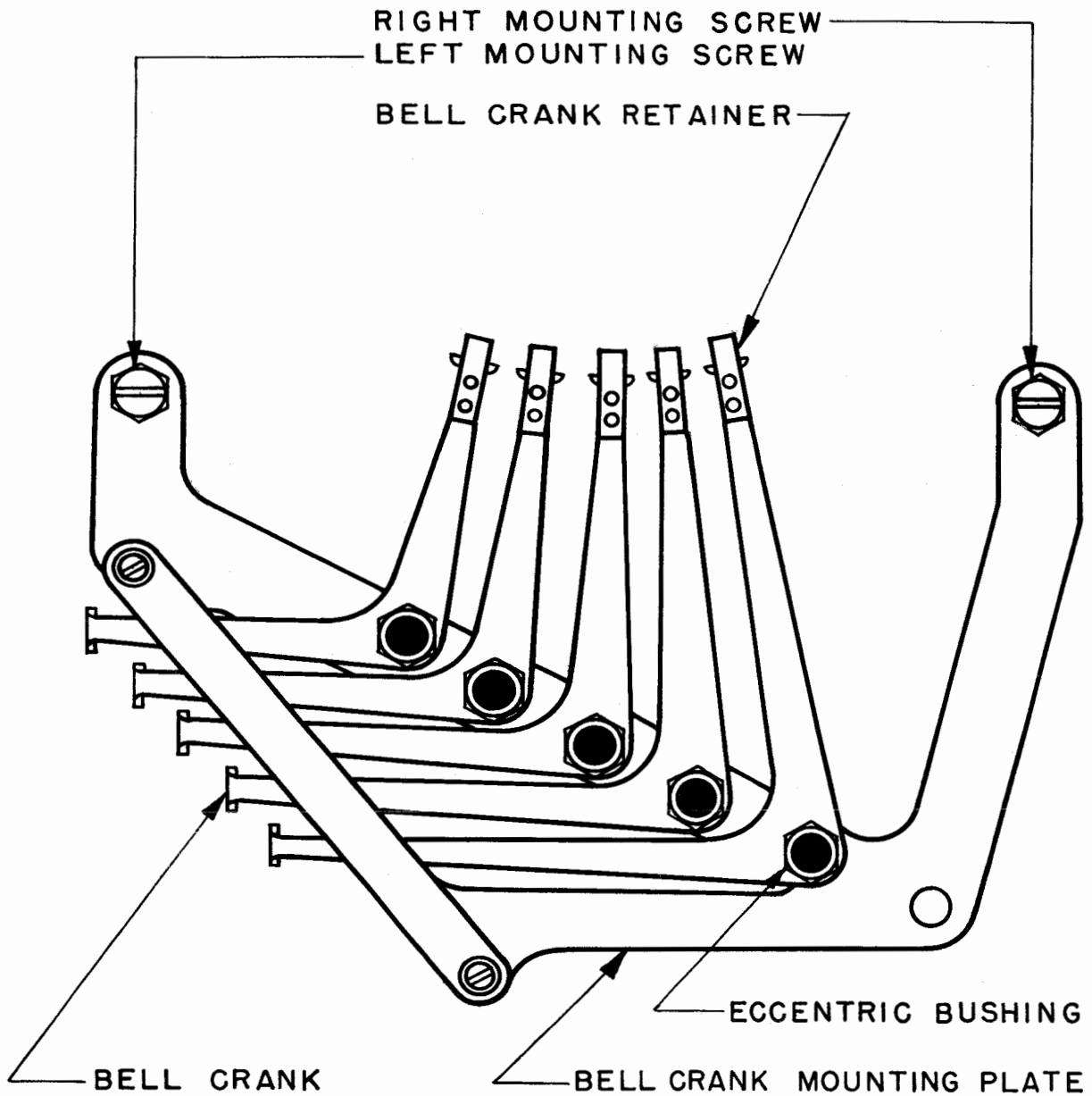

Figure 18

when the clutch is fully cammed out of engagement. See Figure 21.

To Adjust: Reposition the clutch-throwout-lever pilot screw, making sure that the throwout lever is free in its bearings with some endplay, not more than 0.002 inch, when the pilot-screw lock nuts are tightened.

2.36 Clutch-throwout-lever Spring should have a tension of minimum 2-1/2 ounces, maximum 4 ounces, measured at right angles to the throwout lever but with the clutch teeth fully engaged. See Figure 21.

2.37 Mainshaft-clutch Spring

Speed	Tension	Use Spring
60	Min 22 oz, Max 30 oz	TP6993
75	Min 32 oz, Max 42 oz	TP122059

Note: The TP122059 spring has one end painted yellow for identification.

To Gauge: Apply a scale to the driven member of the clutch when the tips of the teeth are resting against each other and the low part of the printing-bail cam is toward the bottom of the typing unit. The

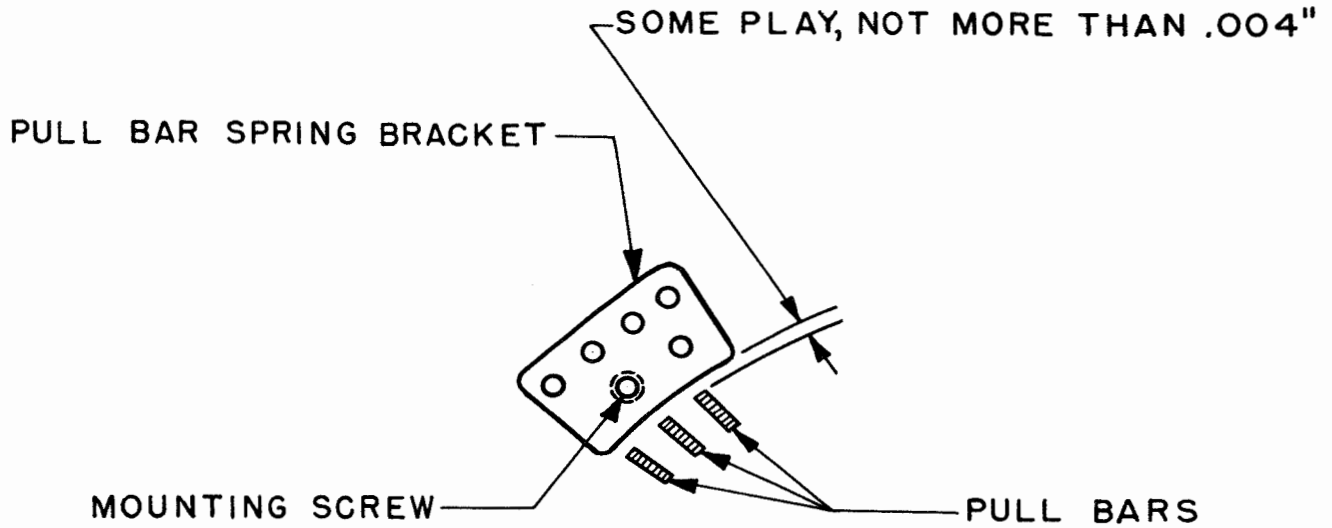

Figure 19

tensions indicated should just separate the clutch teeth. See Figure 22.

2.38 Clutch-driven Member: After being pulled manually to the position of extreme disengagement, the driven member should move freely without bind on the mainshaft.

To Gauge: Pull the driven member to its operated position with the maximum tension specified in 2.37; gradually reduce the tension and permit the driven member to slide until it touches the driving member. The gauge reading should not go below 10 ounces.

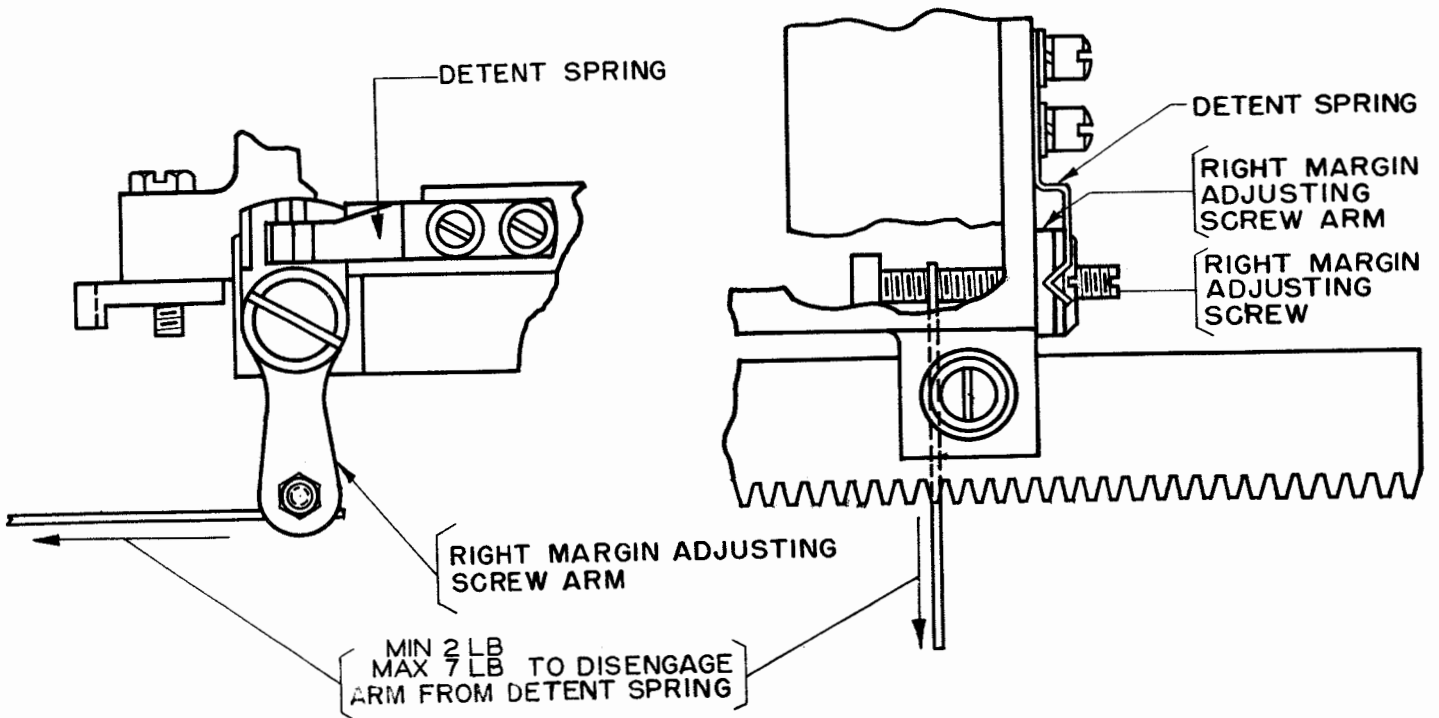

Figure 20

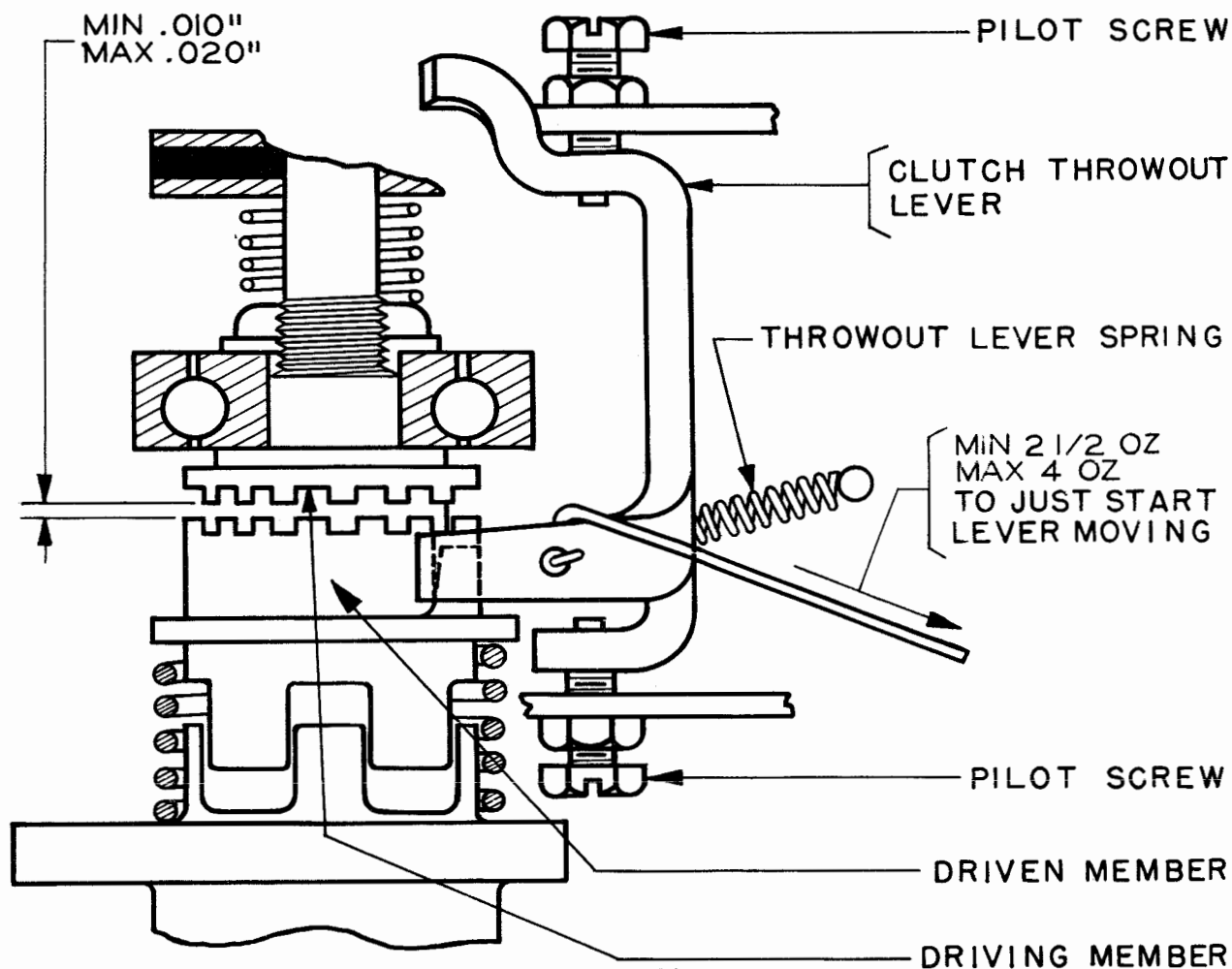

Figure 21

To Adjust: Clean and lubricate the clutch. If the sliding surfaces of the driven member and bushing on which it slides are not smooth and polished, replace these parts.

Note 1: Failure to receive the first character after a period of idleness may be caused by sticking of the mainshaft clutch parts. This trouble may be checked by observing the typing of the first character received directly from the associated keyboard after the mainshaft of the typing unit has been at rest for at least 10 minutes with the power disconnected. This difficulty may be eliminated by replacing the printing and function-bail cam-follower rollers with TP91175 cam-follower roller assemblies (roller-bearing cam followers).

Note 2: Place the typing unit in its normal upright position.

2.39 Spacing-shaft Gear and the mainshaft-spacing gear should engage with minimum backlash without bind at the closest point in a complete revolution of the spacing-shaft gear, gauged by eye and feel, when the carriage-return operating-lever spring is unhooked from its bearing bracket. See Figure 23.

To Adjust: Loosen the spacing-shaft-gear bearing-bracket eccentric screw, reposition the spacing-shaft bracket, and then position the eccentric snugly against the bracket.

2.40 Printing-bail-shaft Right Bearing: The printing bail should have some endplay, not more than 0.015 inch, as measured between the end of the printing-bail casting and the printing-bail-shaft left bearing with the printing bail in its extreme forward position and held

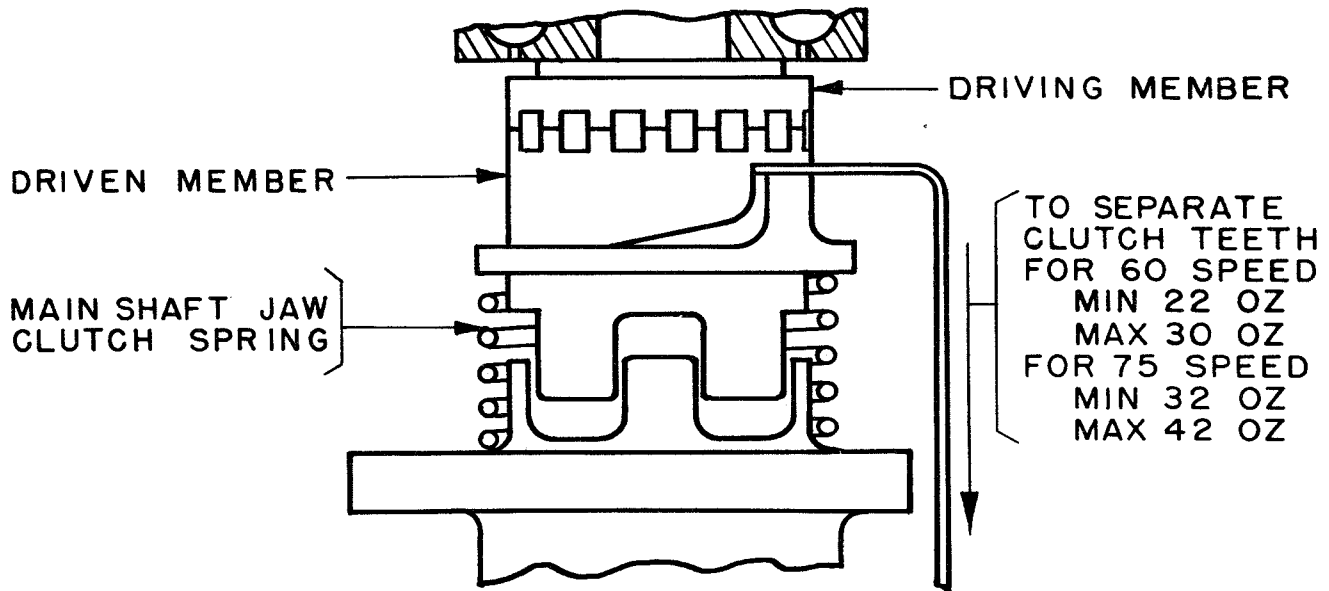

Figure 22

toward the right and the printing-bail spring unhooked. See Figure 29.

To Adjust: Loosen the right-hand bail-shaft-bearing mounting screws and position the bearing.

Note: Reassemble the typebar carriage on the typing unit as follows: With the platen in the FIGS position, the printing bail in its rearmost position, and the carriage right-margin adjusting-screw arm moved to the rear so that it is approximately 45 degrees from the vertical, rest the left front carriage-support roller on the right end of the front carriage track, making sure the carriage guidescrew engages the slot in the carriage track. Position the upper gear of the spacing shaft so that the first full tooth on the carriage-gear rack engages the hollow directly above the numeral 1 (one) of the part number stamped on the upper spacing-gear. Move the carriage slowly to the left until the rear carriage-support roller rests on the upper track, operate the manual carriage-return lockbar, and then force the pullbar bail to the extreme rear position by pushing on the right pullbar-bail roller with the right thumb. Move the carriage further to the left, making sure that the bellcranks engage their respective vanes and that the right front carriage-support roller and the guide-screw properly engage the front carriage track.

After the carriage has been moved far enough to the left to permit the right-margin adjusting-screw to clear the spacing stoplever, restore the screw arm to its normal vertical position and then shift the carriage to a position where the draw strap can be attached. While grasping the draw strap with the left hand to prevent the spring drum from unwinding, unhook the strap from the margin-bell-hammer-arm stop post and hook it over its post on the carriage. Move the carriage to the right until the slack in the strap is taken up and then allow the carriage to restore to its extreme left position. Note that the margin-bell spring is correctly positioned, and where form stationery is used, check the left-hand margin adjustment.

2.41 **Pullbars** should clear the codebars by minimum 0.010 inch, maximum 0.050 inch when the mainshaft is rotated until the printing bail is in its extreme rear position and the play in the pullbars is taken up toward the code bars. See Figure 24.

Note: Check with the carriage at both extreme right and left positions.

To Adjust: Reposition printing-bail adjusting screw.

REMOVE THE TYPEBAR CARRIAGE (SEE NOTE ABOVE 2.01).

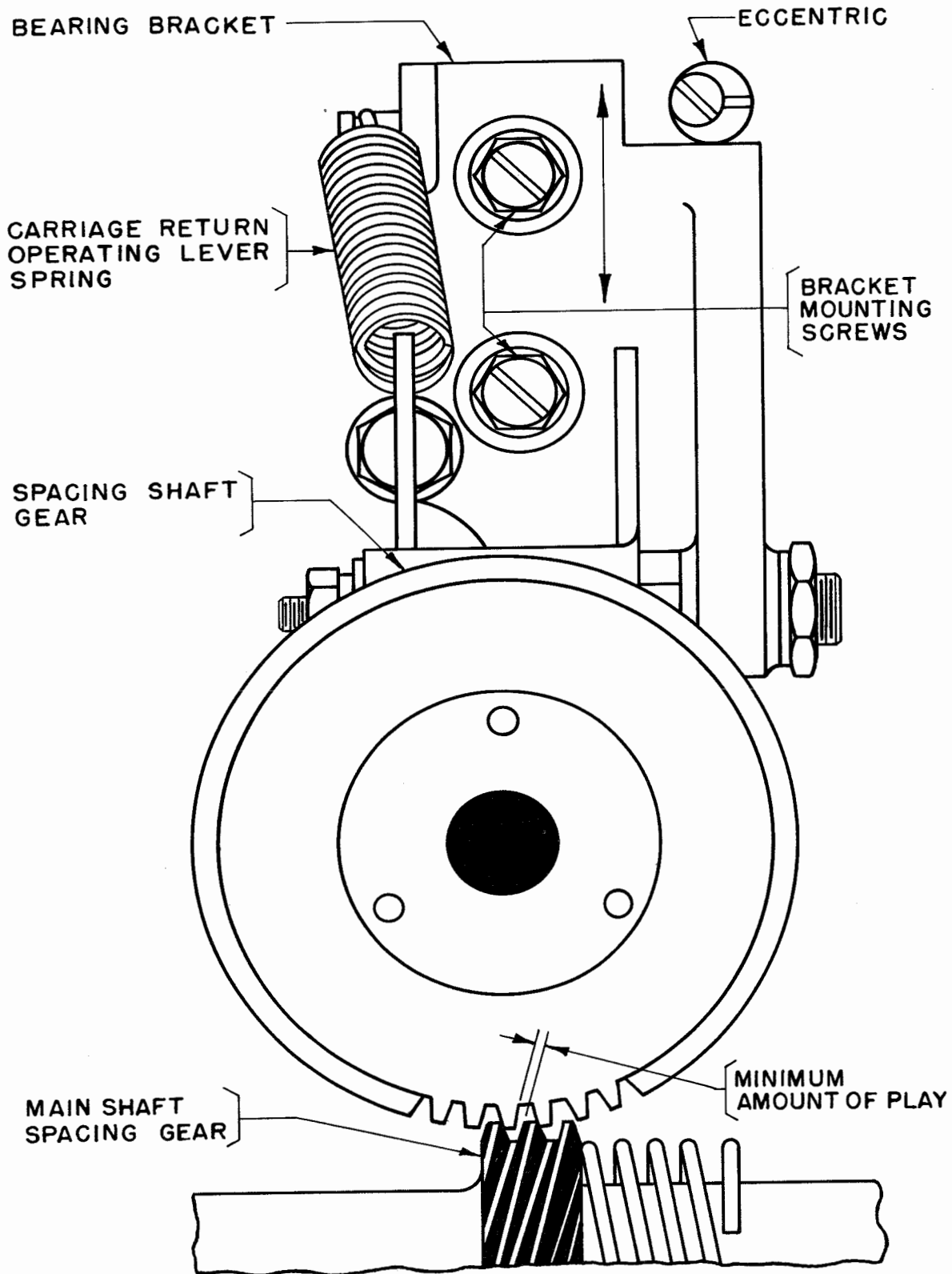

Figure 23

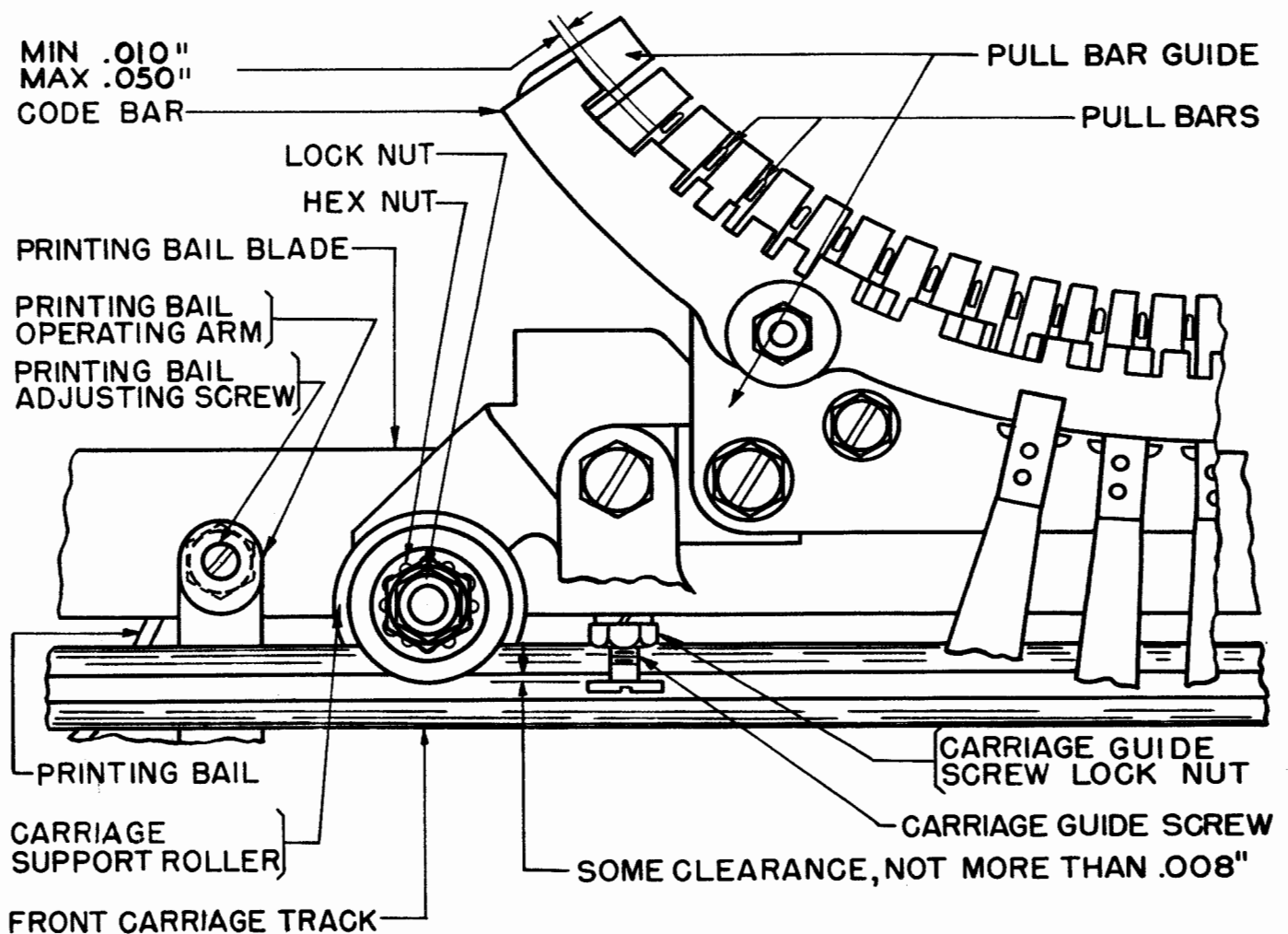

Figure 24

2.42 Function-lever Bail: The front edge of the function levers, except the universal function-lever (position 5), should clear the rear edge of the No.1 vane by minimum 0.040 inch, maximum 0.060 inch when the vane is held midway between the marking and spacing positions and the mainshaft is rotated until the printing bail is in its rearmost position. See Figure 25.

Note: On typing units equipped with one-piece function-lever bail, this clearance should be checked and adjusted after 2.43 and 2.44 have been checked and adjusted.

To Adjust One-piece Bail: Remove or add shims under the bail at the mounting screws; to adjust two-piece bail, reposition the bail toward the front or rear of the teletypewriter.

Note: If clearance on one-piece bail is re-adjusted, recheck 2.43 and 2.44. See Figures 25 and 26.

2.43 Function-lever Bail and Blocking Plate:

The function-lever bail should be blocked by the selected-function lever and the front edge of the bail's right blocking surface should be flush within 0.005 inch of the top front edge of the carriage-return function-lever's rear prong, gauged by eye, when the carriage-return combination is set up and the mainshaft is rotated until the carriage-return function lever is drawn completely into selection with the vanes.

To Adjust One-piece Bail: Reposition right end of the function-lever bail; to adjust two-piece bail, reposition the right end of the blocking-plate. See Figure 26.

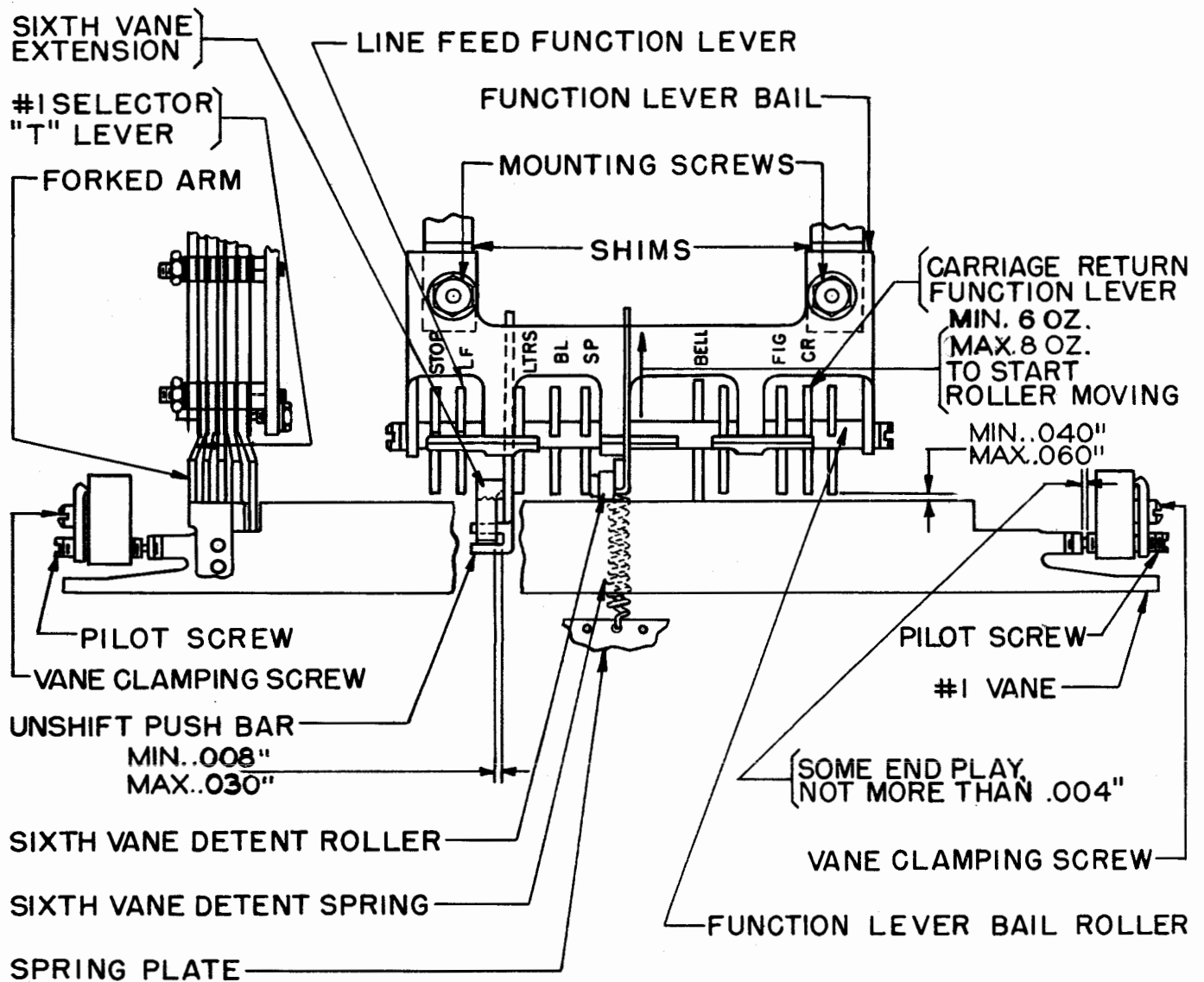

Figure 25

Note: If necessary to readjust one-piece bail, recheck 2.42 after checking 2.44.

2.44 Function-lever Bail should be blocked by the selected-function lever and the front edge of the bail's left blocking surface should be flush within 0.005 inch of the top front edge of the line-feed function-lever's rear prong, gauged by eye, when the line-feed pushbar is removed, the line-feed combination is set up, and the mainshaft is rotated until the line-feed-function lever is drawn completely into selection with the vanes.

To Adjust One-piece Bail: Rotate the left end of function-lever bail around the right

mounting screw. To adjust two-piece bail, rotate the left end of the blocking plate around the right-mounting screw.

Note: If it is necessary to readjust one-piece bail recheck 2.42, if it is necessary to re-adjust two-piece bail recheck 2.43.

2.45 Sixth-vane Extension Spring, on units so equipped, should exert a pressure of minimum 3/4 ounce, maximum 1-1/4 ounces as the extension starts to move away from the vane when the vane is removed from the typing unit and is held in a horizontal position with the extension extending upward. See Figure 27.

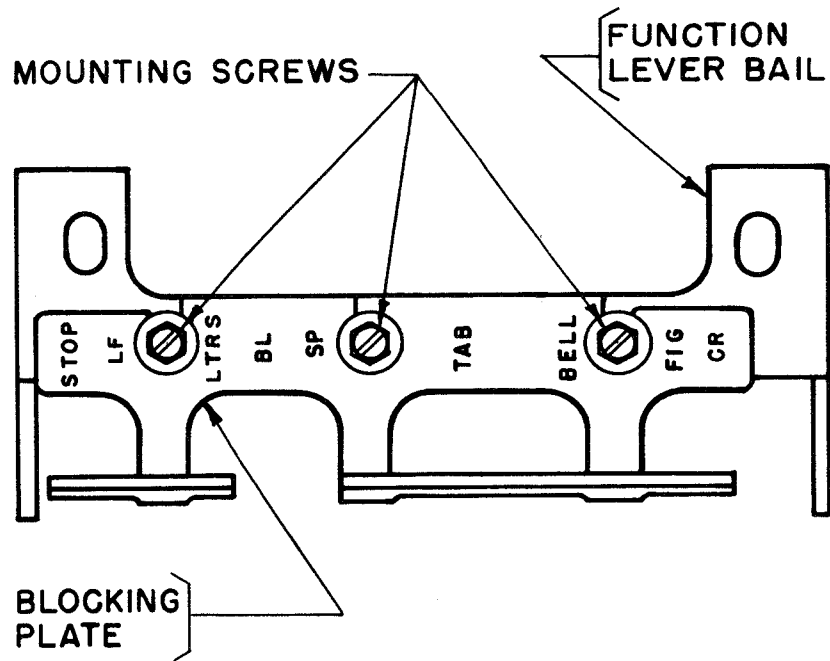

Figure 26

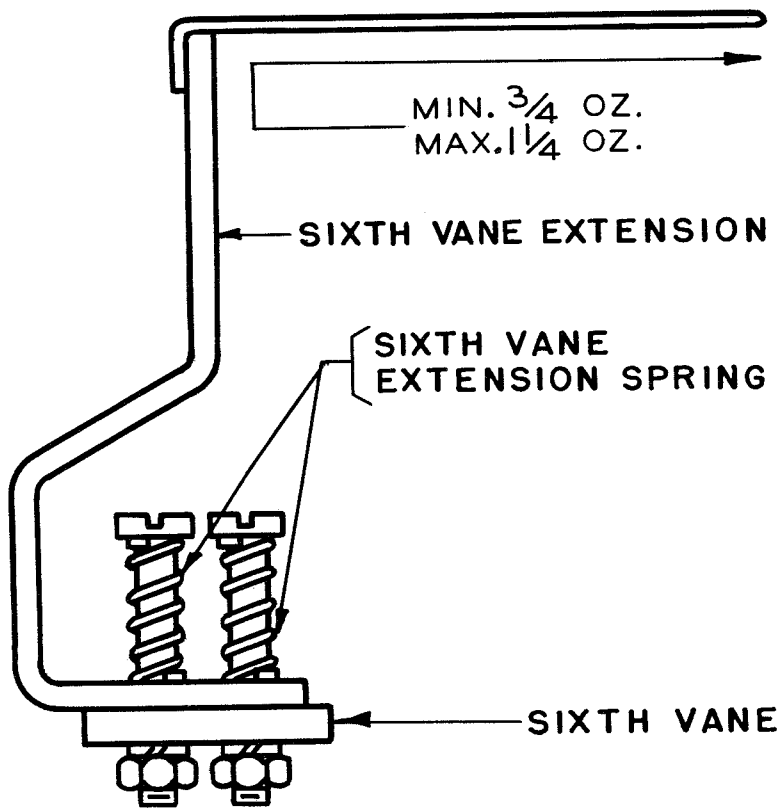

Figure 27

Note: Check this tension in the opposite direction also.

2.46 Selector Vanes should be free of bind and have endplay not to exceed 0.004 inch when the printing bail is in its extreme rear position and, except the sixth (see 2.47), should be positioned so that their forked arm lines up with the corresponding T lever, gauged by eye. See Figure 25.

Note: To check for bind, hold the swords away from the T levers. If a vane has bind and endplay, check for bind in the associated T lever by disconnecting the vane from the T lever.

To Adjust: Reposition the vane pilot screws. Clean the vane and the T lever bearings, if necessary.

2.47 Sixth Vane: With the platen in the LTRS position, the forward edge of the sixth

vane should be held in its lowest position without exerting pressure to spring or bend the parts involved. The vane should be free of bind and have some endplay, not to exceed 0.004 inch, gauged by eye. There should be minimum 0.008 inch, maximum 0.030 inch clearance between the right edge of the vane extension and the right end of the slot in the LTRS pushbar. See Figures 25 and 27.

Note: Extension on old-style sixth vanes is a flat member formed of spring steel. That on the new-style vanes is formed steel mounted by means of shoulder screws, springs, lock-washers, and nuts.

To Adjust: Reposition the vane pilot screws.

2.48 Function-bail Spring should have a tension of minimum 2 pounds, maximum 3 pounds when the bail is in its extreme rear position. See Figure 28.

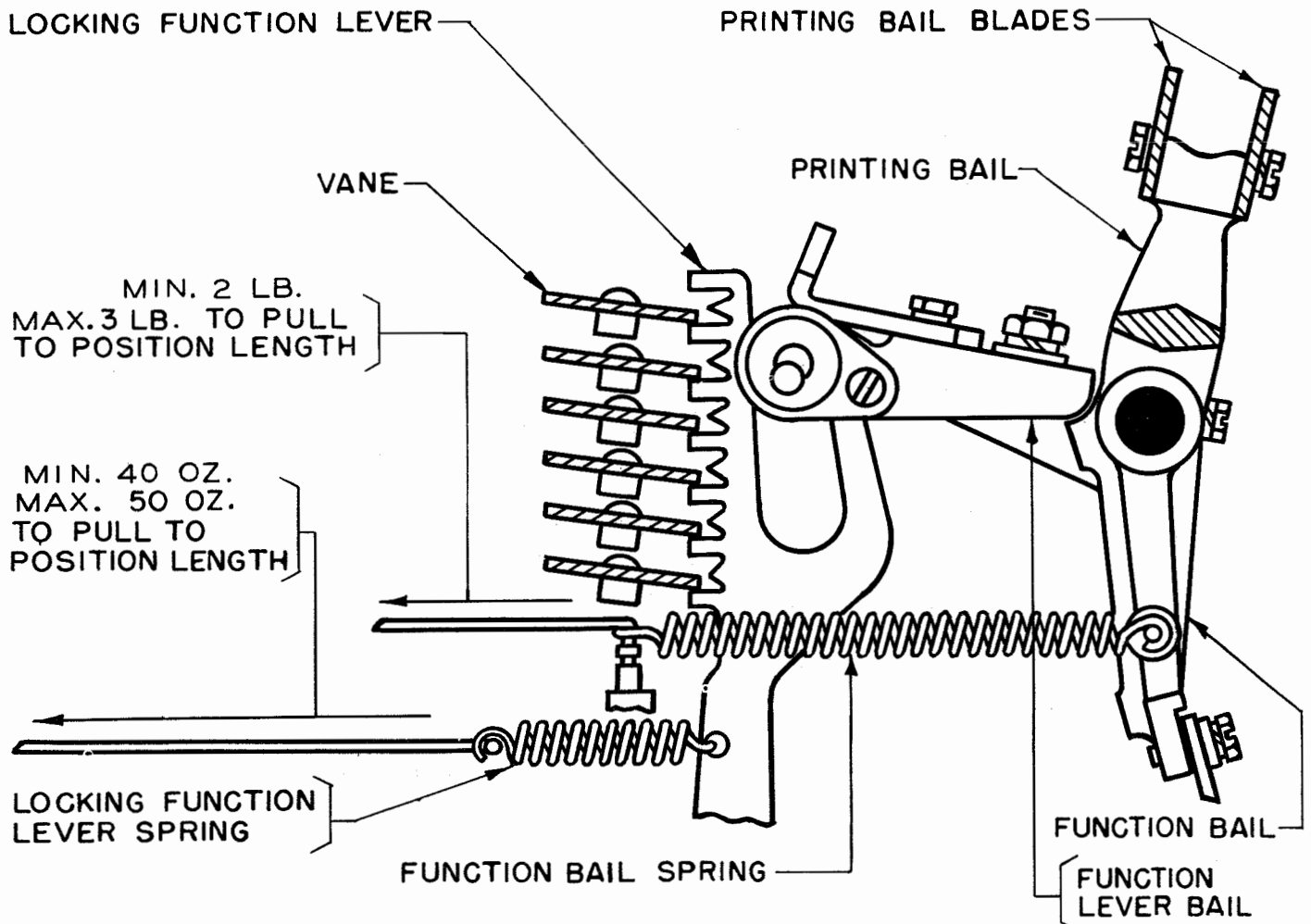

Figure 28

2.49 Printing-bail Spring should have a tension of minimum 6-1/2 pounds, maximum 8-1/2 pounds when the bail is in its extreme rear position. See Figure 29.

Note: For making one or two copies it may be desirable to adjust the tension toward the minimum limit. For more copies, somewhat greater spring tension may be required in order to obtain good carbon copies.

To Adjust: Reposition the spring-adjusting lever.

PLATEN MECHANISM ADJUSTMENTS (2.50 to 2.89).

2.50 Platen Unit should be midway between the side frames and should rotate freely on

its bearings with no endplay as gauged by eye and feel.

To Adjust: Disconnect the Line Feed and the shift vertical links at the upper-shoulder screws, unhook the platen balance and shift-detent springs, and reposition the platen-unit pilot screws. See Figures 30, 34, and 35.

2.51 Platen-shift Stop-post top and bottom surfaces should be parallel to a line through the center of the platen-detent roller and the platen-unit pilot screws as gauged by eye. See Figure 30.

To Adjust: Reposition the post.

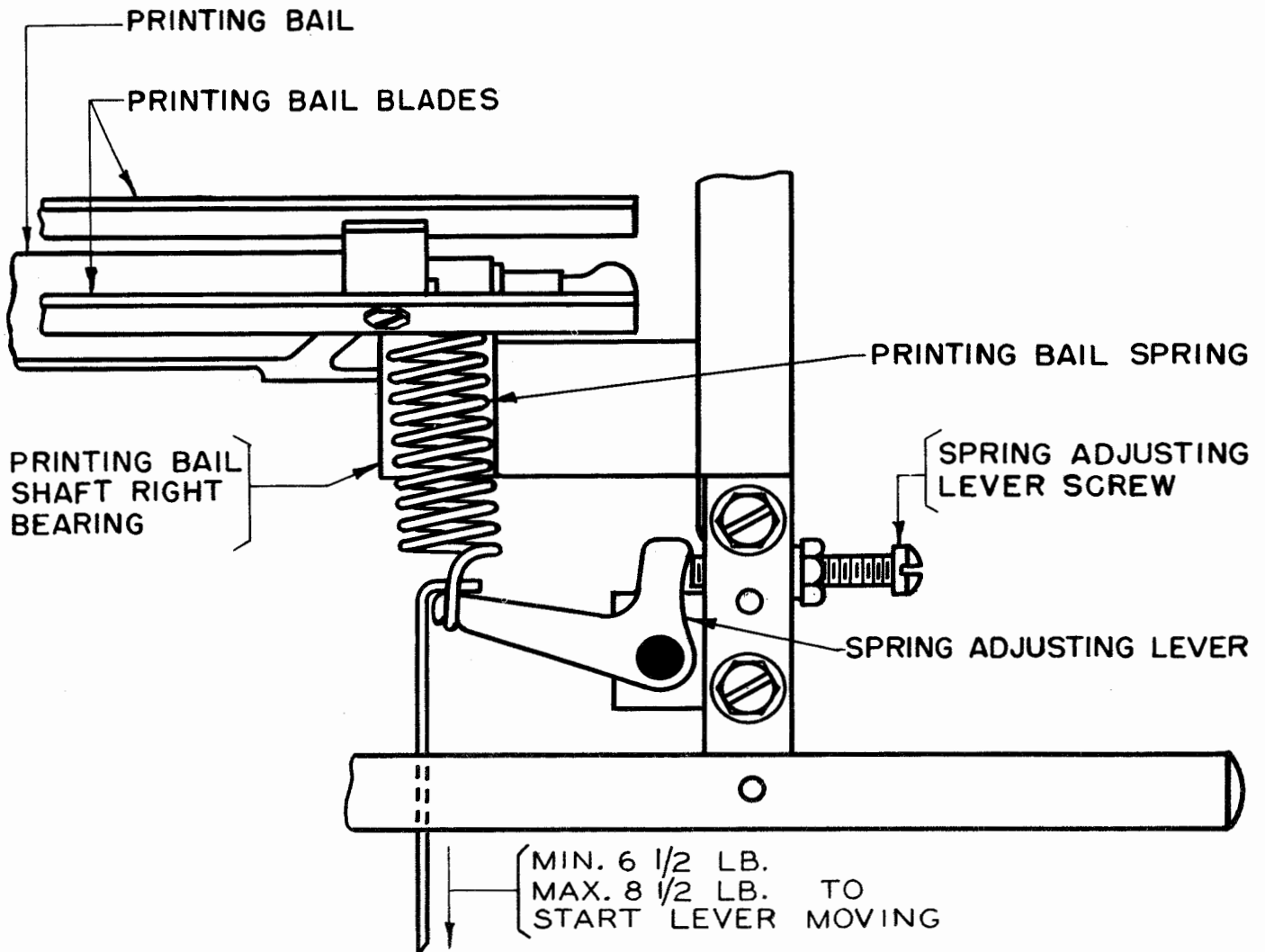

Figure 29

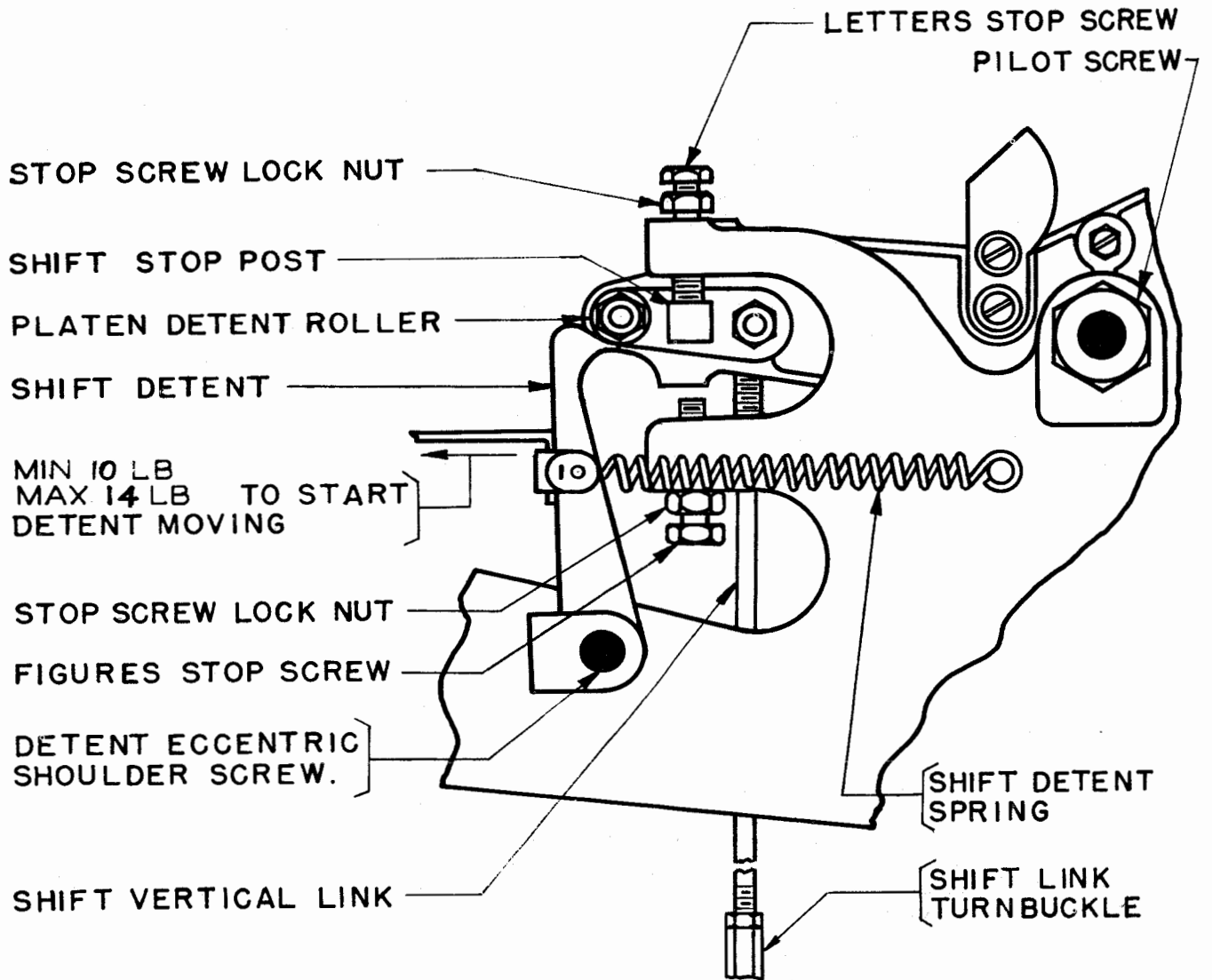

Figure 30

Note: Reassemble the typebar carriage on the typing unit (see note under 2.40).

2.52 LTRS Stop Screw: Letter N should type uniformly top and bottom with the platen in the LTRS position.

To Adjust: Raise the LTRS stop screw if the impression is light at the bottom, and lower the screw if light at top. See Figure 30.

2.53 FIGS Stop Screw: Top of Figure 5 typed with the platen in the FIGS position should type in line with the top of the letter T typed with platen in the LTRS position. Gauge by eye.

To Adjust: Reposition the FIGS stop screw. See Figure 30.

Note: Remove the typebar carriage from the typing unit (see note above 2.01) and place the typing unit on its right side.

2.54 FIGS, Line-feed, and LTRS Function Levers should be free of bind and the tension of their springs should be minimum 15 ounces, maximum 19 ounces, measured as at (b) when (1) the blank combination is set up, (2) the mainshaft is rotated until the printing bail is in its extreme forward position, and (3) the pushbars are held away from the function levers. See Figure 31.

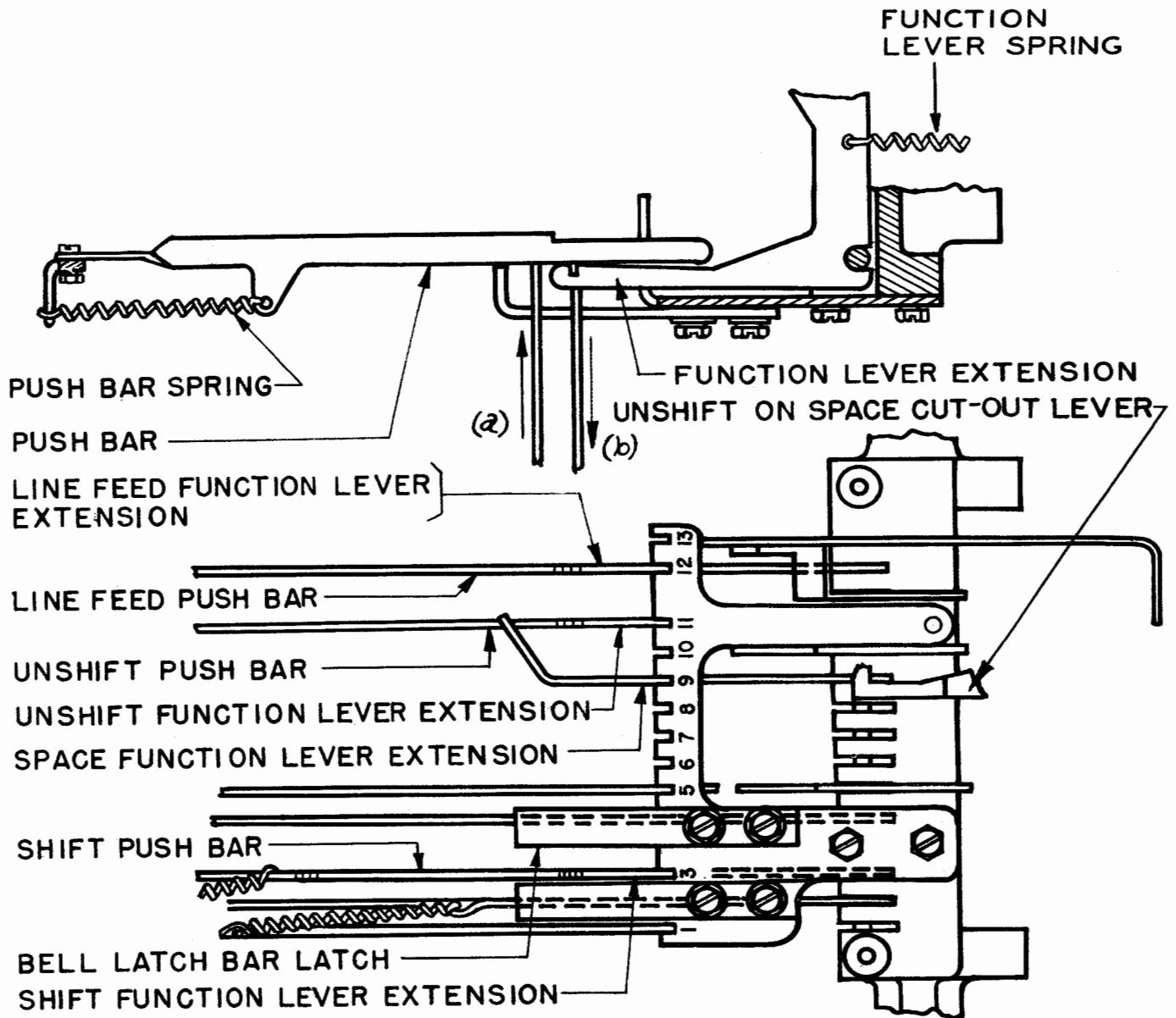

Figure 31

2.55 Space-function-lever Spring should have a tension of minimum 12 ounces, maximum 16 ounces, measured as at (b) when the space-function lever is resting against the vanes but not selected and the letters pushbar is held away from the function lever. See Figure 31.

2.56 Blank Printing and Spacing Cut-out Function-lever Spring on units so equipped should have a tension of minimum 22 ounces, maximum 30 ounces when the printing bail is in the extreme rear position and the spring is unhooked from the spring plate and stretched to position length.

2.57 Function-bail Blade: The FIGS, Line Feed, LTRS, and Space function levers should clear the rear edge of the No.1 (top) vane by minimum 0.004 inch, maximum 0.015 inch when the function combination of the lever being checked has been set up and the mainshaft is rotated until the function-lever bail is blocked by the selected-function lever, except in the case of the space-function lever which should meet the requirement when (1) the unshift on space cut-out lever is released from the lower space-function-lever extension, (2) the platen is in the FIGS position, (3) the space combination is set up, and (4) the mainshaft is rotated until

the function-lever-bail roller just leaves the cam surface of the space-function lever. See Figures 32 and 33.

Note: Before readjusting, check 2.59, and if the shift stop-post does not meet the requirements of 2.59, place the shift-bellcrank-operating-lever bracket in its extreme rear position, proceed with this adjustment and then adjust the shift-bellcrank operating-lever bracket in accordance with 2.59.

To Adjust: Set up the FIGS combination and rotate the mainshaft until the function-lever bail is stopped by the FIGS function-lever bail blade. Similarly reposition the right end of the Line Feed combination and reposition the left end of the function-bail blade. Then check the clearance of the LTRS and space-function levers in turn. If necessary, reposition the blade for clearance of the LTRS or space-function levers, recheck the FIGS and the Line Feed function lever clearances.

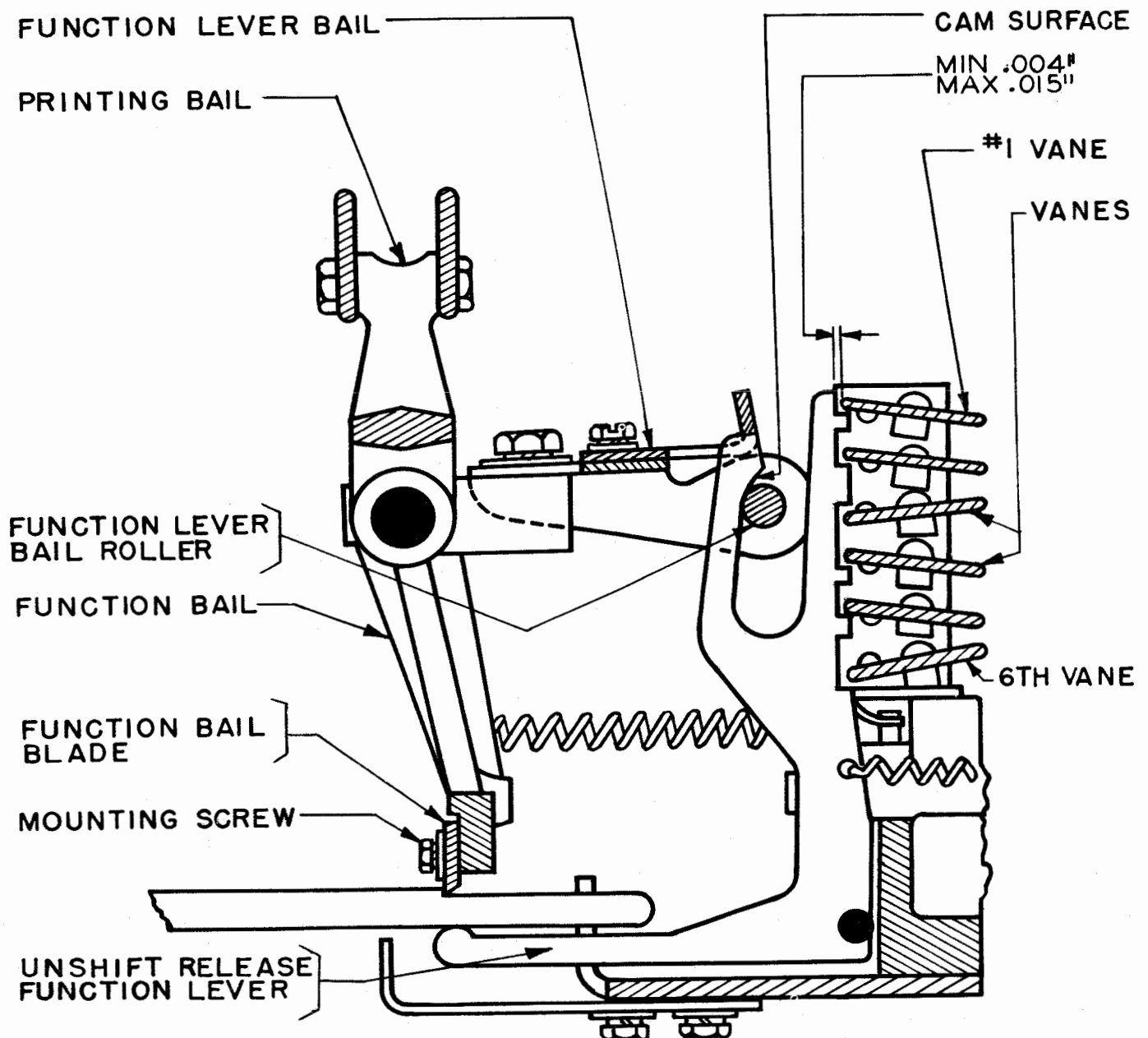

Figure 32

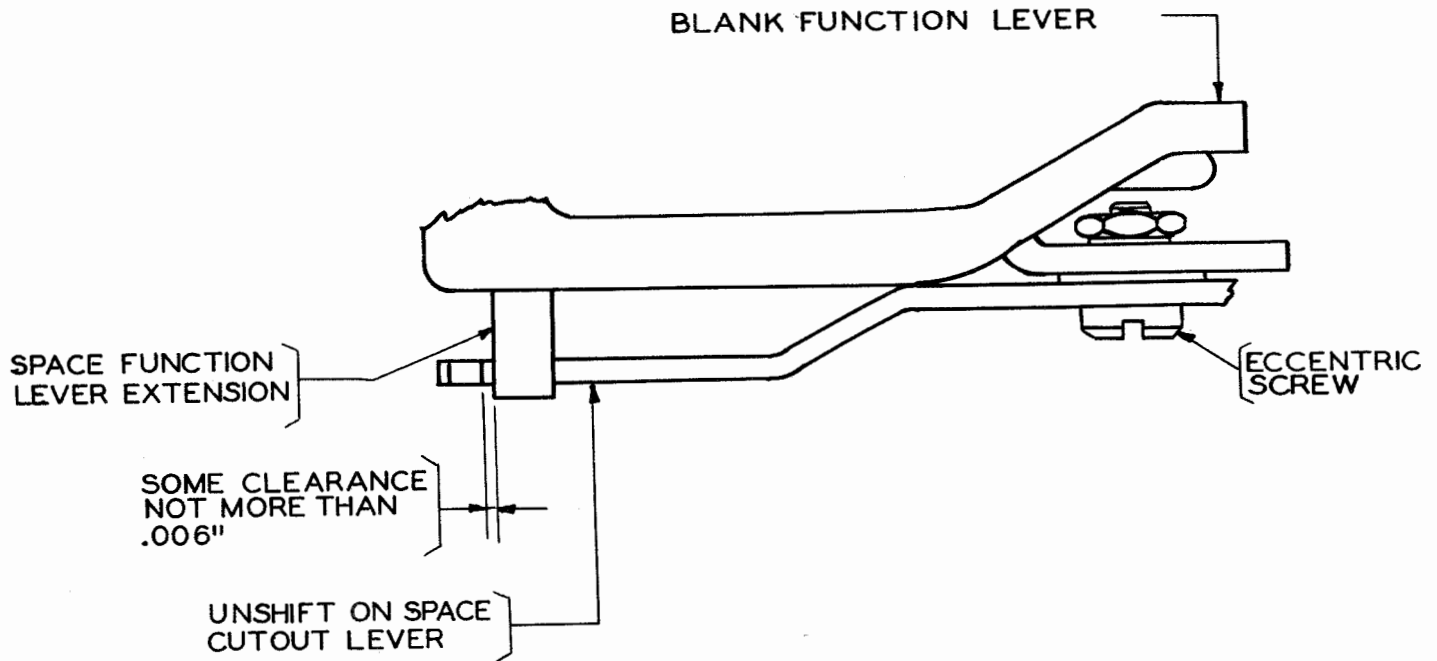

Figure 33

2.58 Unshift-on-space Cut-out Lever should be rotated counterclockwise (viewed from bottom) until it rests against its stop. See Figure 31.

Note: Where it is desired on certain private-line services that the platen should not return to LTRS position when space combination is received, the unshift-on-space cut-out lever should be positioned to touch the side of the space-function lever and the cut-out-lever toe should be to the rear of and clear the space-function lever lower extension by not more than 0.006 inch when the printing bail is in its extreme rear position. See Figure 33.

To Adjust: Reposition the space cut-out lever and its eccentric screw.

Note: T lever and attached mechanism may be removed from its mounting post to facilitate making this adjustment.

2.59 Shift Stop-post should clear the LTRS and FIGS stop screws by minimum 0.010 inch, maximum 0.025 inch, when the shift detent and platen-balance springs are removed, the platen is shifted from one position to another by selecting alternately the LTRS and FIGS selections and rotating the mainshaft until the selected pushbar is moved to its rearmost position

by the function-bail blade. These two clearances should be within 0.010 inch of each other. See Figures 30, 31, and 34.

To Adjust the Shift-link Turnbuckle: Reposition until the two clearances are equal within 0.010 inch, then if either clearance is more than 0.025 inch move the shift-link bracket toward the front of the typing unit, if less than 0.010 inch move the bracket toward the rear. If it is necessary to move the bracket, recheck to see that the clearances are equal.

Note: If the shift-link bracket has been removed for other reasons it should be assembled on the typing unit in the middle of its elongated-mounting holes and the shift-link turnbuckle should be adjusted so that the function-bail blade in its extreme forward position clears the notches in the LTRS and FIGS pushbars by the same amount within 0.010 inch when the latter are selected, before the above adjustment is made.

Note: Place the typing unit in its normal upright position.

2.60 Platen-balance-spring tension, measured when the platen is in the LTRS position, should be: (See Figure 34.)

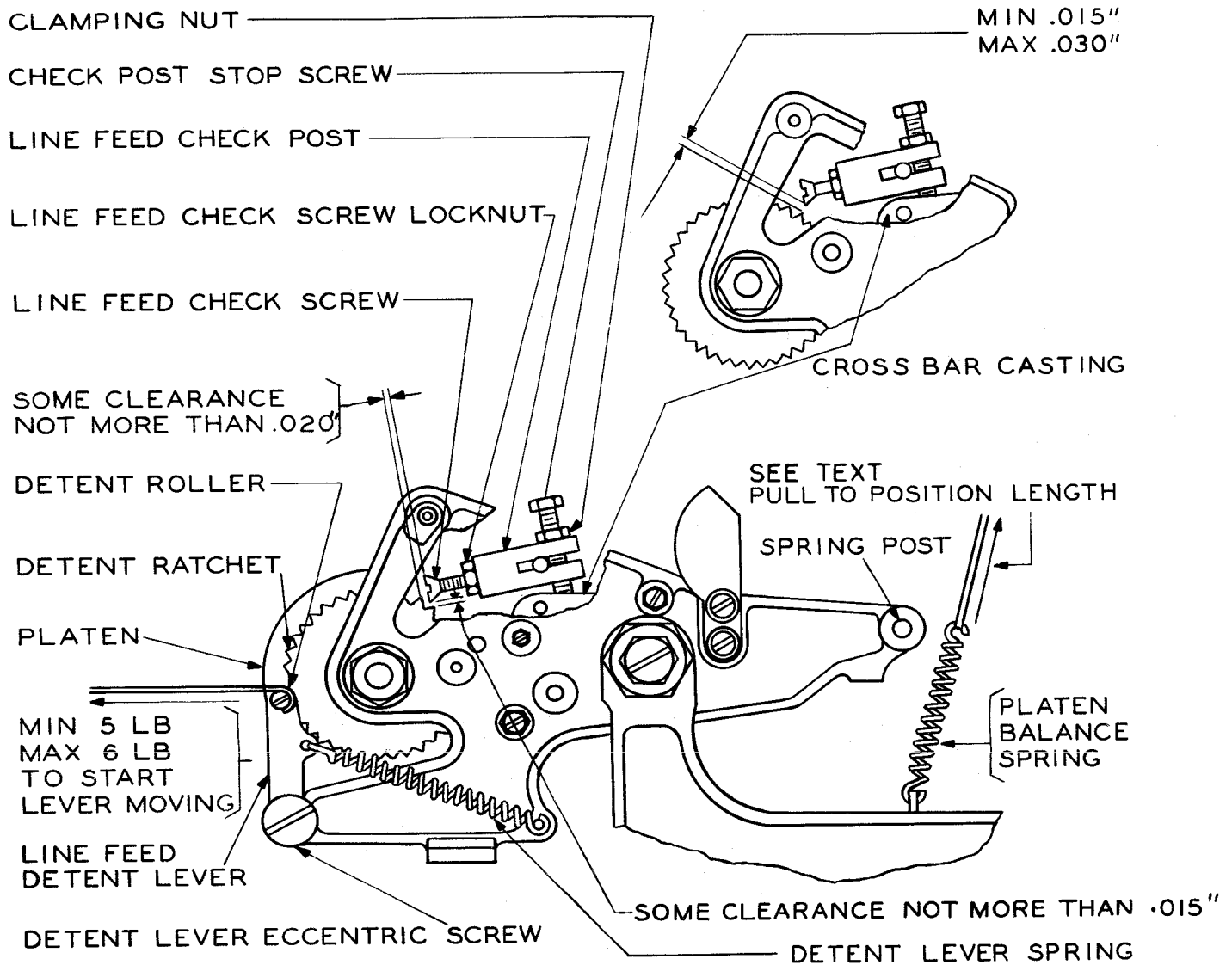

Figure 34

Platen Brackets	Tension
Black-enamelled iron	Min 3-1/2 lb, Max 5 lb
Aluminum	Min 20 oz, Max 32 oz

2.61 Shift Detent should ride the same distance on either side of platen-detent roller, gauged by eye, when the platen is shifted from FIGS to LTRS position. See Figure 30.

To Adjust: Reposition the eccentric shoulder screw of the shift detent.

2.62 Shift-detent Spring: The shift-detent spring should have a tension of minimum 10 pounds, maximum 14 pounds. See Figure 30.

2.63 Sixth-vane Extension: On typing units equipped with the old-style sixth-vane extension (a flat spring formed from spring steel), the sixth vane should travel an equal amount, gauged by eye, either side of the detent in the W notch of the locking-function lever when the vane's detent spring is unhooked from its spring plate and the platen is shifted from the LTRS to FIGS position.

To Adjust: Bend the sixth-vane extension, making sure it does not bind in the slot of the LTRS pushbar when in either the LTRS or the FIGS position. Check 2.45.

2.64 LTRS and FIGS Pushbar Springs should exert a pressure of minimum 3 ounces,

maximum 5 ounces, measured as at (a) in Figure 31 when any character has been selected and the mainshaft is rotated until the printing bail is in its extreme forward position.

2. 65 Platen Shaft should have endplay not to exceed 0.004 inch.

To Adjust: Reposition the friction-drag assembly on the platen shaft.

2. 66 Single-double Line-feed Detent should travel an equal distance on either side of detent-spring hump, gauged by eye, when the detent lever is shifted from the single to the double line-feed position. See Figure 35.

Note: This does not apply on units equipped with the TP87692 set of parts for feeding four lines per inch.

To Adjust: Reposition the detent.

2. 67 Single-double Line-feed Detent Spring should exert a pressure of minimum 1-1/4 pounds, maximum 3-1/4 pounds. See Figure 35.

Note 1: This does not apply on units equipped with the TP87692 set of parts for feeding four lines per inch.

Note 2: On typing units having old-style single-double line-feed levers with a handle formed by an extension on the front lever, the detent spring should exert a pressure of minimum 2-1/2 pounds, maximum 4-1/2 pounds, measured at the end of the lever as the latter is pushed from the single to the double line-feed position.

2. 68 Line-feed Pawl should just clear the edge of a ratchet tooth when the single-double line-feed lever is in single line-feed position, the line-feed detent roller is in the hollow between two ratchet teeth and the line-feed bell-crank is operated manually. See Figure 35.

To Adjust: Reposition the line-feed detent lever eccentric-screw to rotate the platen by means of the detent lever, keeping the eccentric head of the screw to the rear of the screw body. Check the adjustment on four ratchet teeth located 90 degrees apart. See Figure 34.

Note: Place the typing unit on the right side.

2. 69 Line-feed Pawl should have advanced the platen one line space so that the line-feed

detent roller is in the hollow between two ratchet teeth and should then clear the front face of the ratchet tooth by not more than 0.010 inch when (1) the single-double line-feed lever is in the single line-feed position, (2) the Line-Feed combination is set up, (3) the mainshaft is rotated until the line-feed pushbar is being stripped from the function-bail blade.

Note 1: On units equipped with the TP87692 set of parts for feeding four lines per inch, the single-double line-feed lever shall be clamped in the "double" line-feed position.

Note 2: Do not take up the play in the line feed mechanism when checking or making this adjustment. The line-feed pawl may be considered to clear the front face of the ratchet tooth if, when the line-feed pawl is engaged with a spring hook close to the spring post, and lifted just above the top or point of the tooth, and then released from the spring hook, it fully returns (i.e., bottoms in) to the hollow of the teeth.

To Adjust: Reposition the line-feed link turnbuckle. See Figure 35.

2. 70 Line-feed Pushbar Spring should exert a pressure of minimum 1-1/2 ounces, maximum 2-1/2 ounces, measured as at (a) when the printing bail is in its extreme rear position. See Figure 31.

Note: Place typing unit in its normal upright position.

2. 71 Line-feed Detent-lever Spring should have a tension of minimum 5 pounds, maximum 6 pounds. See Figure 34.

2. 72 Line-feed Pawl Spring should have a tension of minimum 2 ounces, maximum 4 ounces when the single-double line feed lever is in the double line-feed position and the line-feed pawl is in the unoperated position. See Figure 35.

2. 73 Line-feed Check-screw Head (for 33-tooth ratchet — Bell System) should enter the 12th notch ahead of the one in which the detent roller rests or 14th notch for 37-tooth ratchet — non-Bell System and the top of the screw head should clear the face of the tooth by not more than 0.020 inch when the check screw is held in the bottom of the notch. Check the adjustment on at least four ratchet teeth located 90 degrees apart. See Figure 34.

SECTION 572-202-700

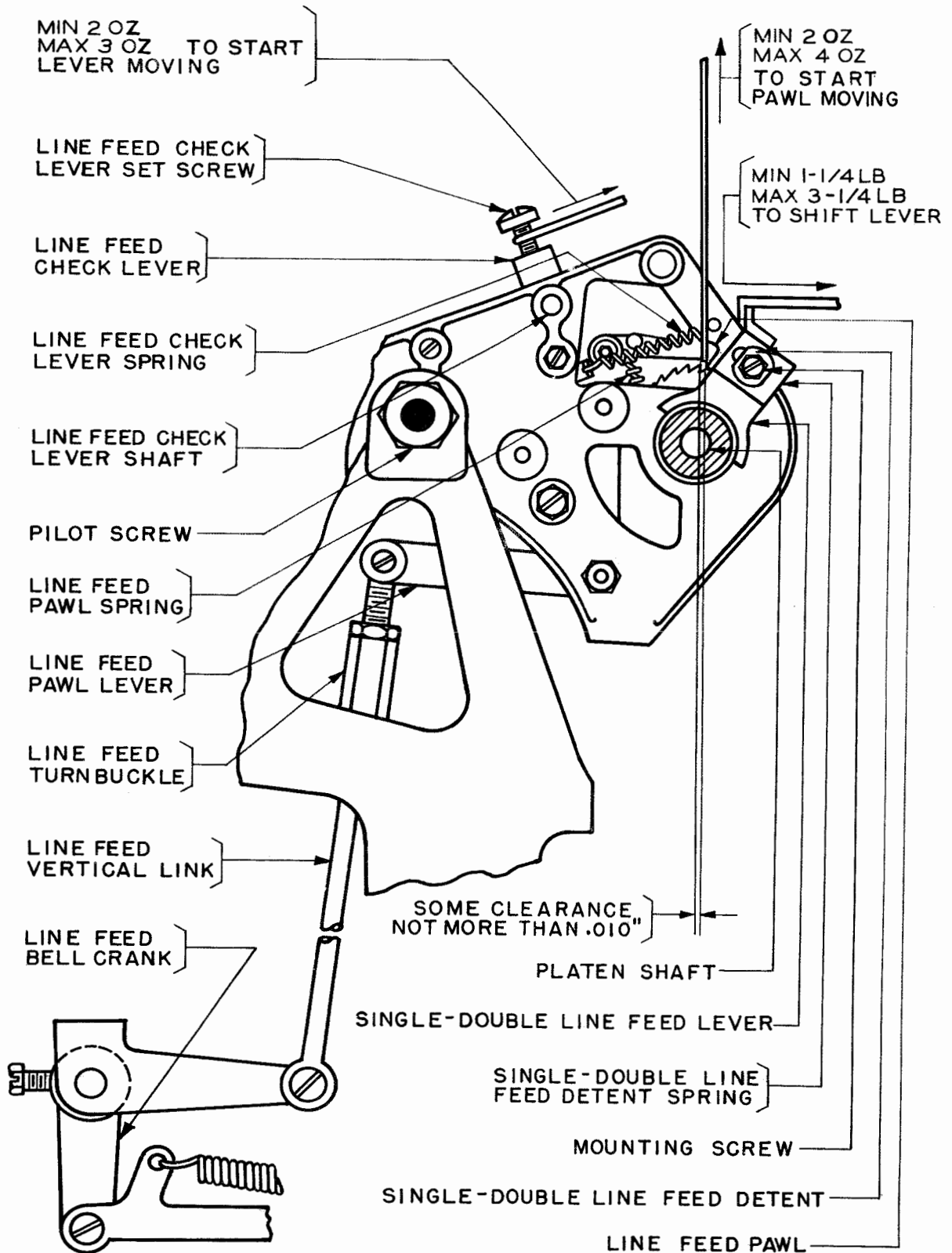

Figure 35

Note: Units equipped with the TP87692 set of parts for feeding four lines per inch should meet this requirement except that the line-feed check-screw head should enter the 8th notch ahead of the one in which the detent roller rests.

To Adjust: Reposition the line-feed check screw. On old-style line-feed check screws having a slotted head with flat sides, the flat sides should be vertical and the adjustment made by turning the screw in or out 1/2 turn at a time. It may be necessary to back off the line-feed check-post stop-screw when making this adjustment.

2.74 Line-feed Check-screw should clear the detent-ratchet teeth by minimum 0.015 inch, maximum 0.030 inch when the line-feed check-stop post is resting on the cross-bar casting. Check the adjustment on four ratchet teeth located 90 degrees apart. See Figure 34.

To Adjust: Turn the platen so that the ratchet tooth showing minimum clearance is opposite the line-feed check-screw and reposition the line-feed check-post. Before tightening the clamping nut, position the check-post against the inner edge of the casting and position the end of the shaft flush with the outside edge of casting.

2.75 Line-feed Check-screw should clear the bottom of each notch on the detent ratchet by not more than 0.015 inch when (1) the Line-Feed combination is set up, (2) the mainshaft is rotated until the line-feed pawl has reached the end of its travel in feeding platen, (3) the line-feed check-lever is against the line-feed pawl lever, and (4) the play of check-lever shaft's right bearing is taken up to make this clearance a maximum. See Figures 34 and 35.

To Adjust: Reposition the line-feed check-lever on the shaft. When tightening the set screw make sure the line-feed check-lever shaft has endplay not to exceed 0.008 inch.

2.76 Line-feed Check-lever Spring should have a tension of minimum 2 ounces, maximum 3 ounces. See Figure 35.

Note: Requirements 2.77 to 2.87 inclusive should be omitted on the sprocket-feed typing units.

2.77 Pressure-roller Release-shaft Arm should clear the boss just to the rear of the

platen-shaft boss by minimum 5/32 inch, maximum 7/32 inch when the right pressure-roller release-shaft collar is against the casting and the arm is opposite the boss. Gauge by eye. See Figure 36.

To Adjust: Reposition the right pressure-roller release-shaft-locating collar. Check 2.78.

2.78 Pressure-roller Release Shaft should have endplay not to exceed 0.004 inch. Gauge by feel. Check 2.79. See Figure 36.

To Adjust: Reposition the left pressure-roller release-shaft-locating collar.

2.79 Pressure-roller Release Cams: With the pressure-roller release-shaft arm in its rear position, the camming surfaces should line up with the release levers. With all the travel of the front pressure rollers taken up manually in a downward direction so that the rear pressure rollers are resting against the platen, there should be at least 0.060 inch between the front pressure rollers and the platen. With all the travel of the rear pressure rollers taken up manually in a downward direction so that the front pressure rollers are resting against the platen, there should be at least 0.060 inch between the rear pressure rollers and the platen.

To Adjust: Position the cams on the release shaft by means of their set screws. See Figure 36.

2.80 Pressure-roller Tension Springs should have a tension of minimum 5 pounds, maximum 6 pounds when the pressure-roller release-shaft arm is in its forward position. The tensions of the springs should also be equal. When a paper winder is used, this tension should be minimum 6-1/2 pounds, maximum 7 pounds. See Figure 37.

To Adjust: Reposition the spring-adjusting levers. In case the paper does not feed straight, adjust with special care and toward the minimum value.

2.81 Pressure-roller Release-lever Shafts: The left end of the left pressure-roller release-lever shaft (viewed from the rear of the teletypewriter) should project beyond the outer surfaces of the left paper-chute-mounting extension and the butt against the platen bracket when the inner surfaces of the two paper-chute-mounting extensions are touching the outer

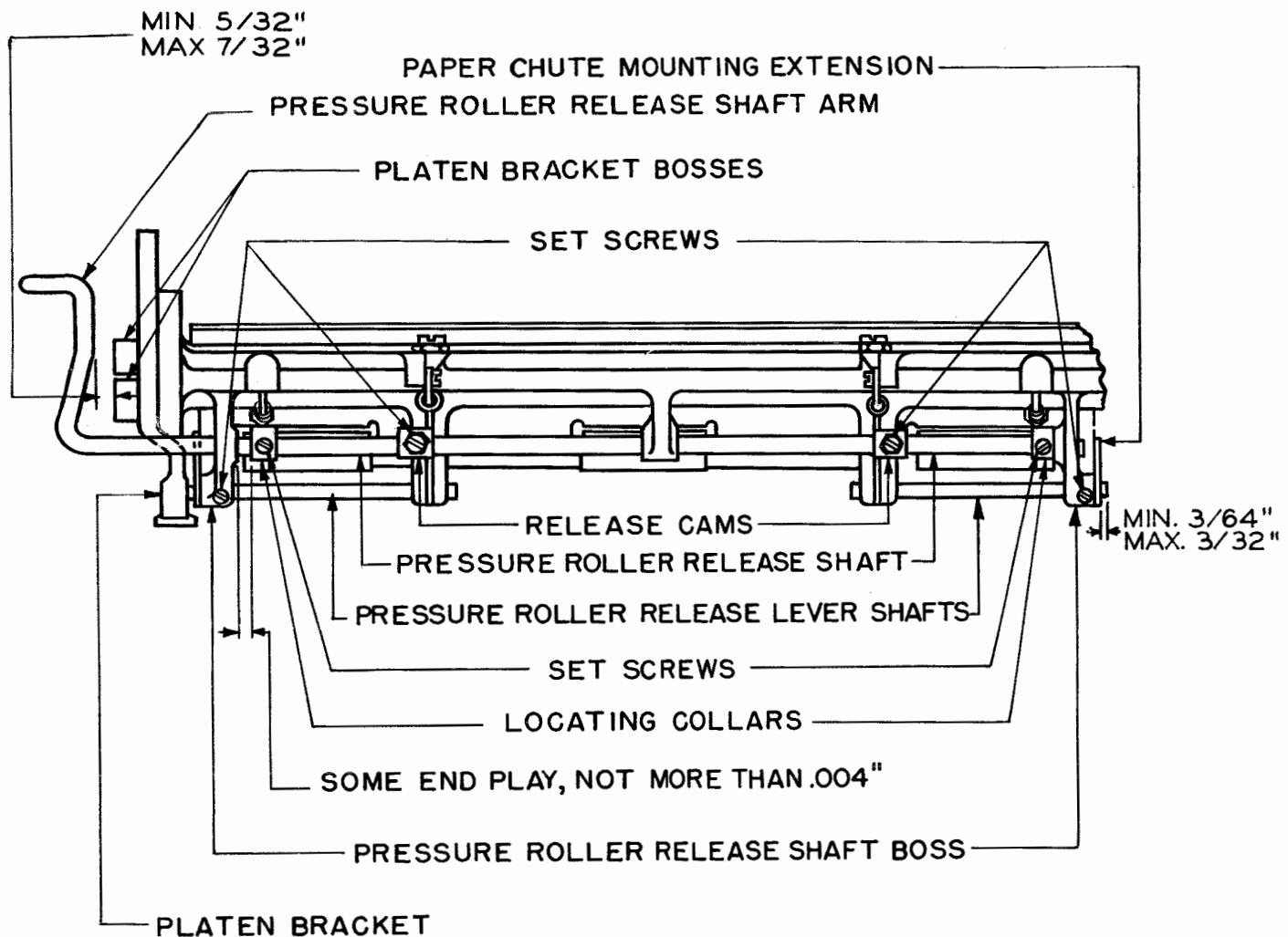

Figure 36

bosses of the two release-lever shafts. The outer end of the right release-lever shaft should project beyond the outer surface of the right paper-chute extension by minimum $3/64$ inch, maximum $3/32$ inch. See Figure 36.

To Adjust: Reposition the release shafts by means of their set screws.

2.82 Paper-chute Spring should have a combined tension of minimum 2 ounces, maximum 7 ounces midway between the side frames when the pressure-roller release-shaft arm is in its operated (rear) position. See Figure 38.

2.83 Paper-finger-shaft Stop-arm should clear its stop post by minimum 0.004 inch, maximum 0.020 inch when the paper fingers are resting against the platen. See Figure 38.

To Adjust: Reposition the paper fingers, keeping the outer edges of the lower extension $3/32$ inch from the end of the platen if 8-1/2-inch paper is used. Gauge by eye. For paper narrower than 8-1/2 inches located at right-hand side of platen, the left-paper finger should be moved in accordingly; for narrow paper centrally located, both fingers should be moved in as required.

2.84 Paper-finger-shaft Spring should have a tension of minimum 16 ounces, maximum 22 ounces. See Figure 38.

2.85 Paper-straightener Rod should clear its stops by minimum 0.030 inch, maximum 0.050 inch when the rod is in its extreme upward position. See Figure 39A.

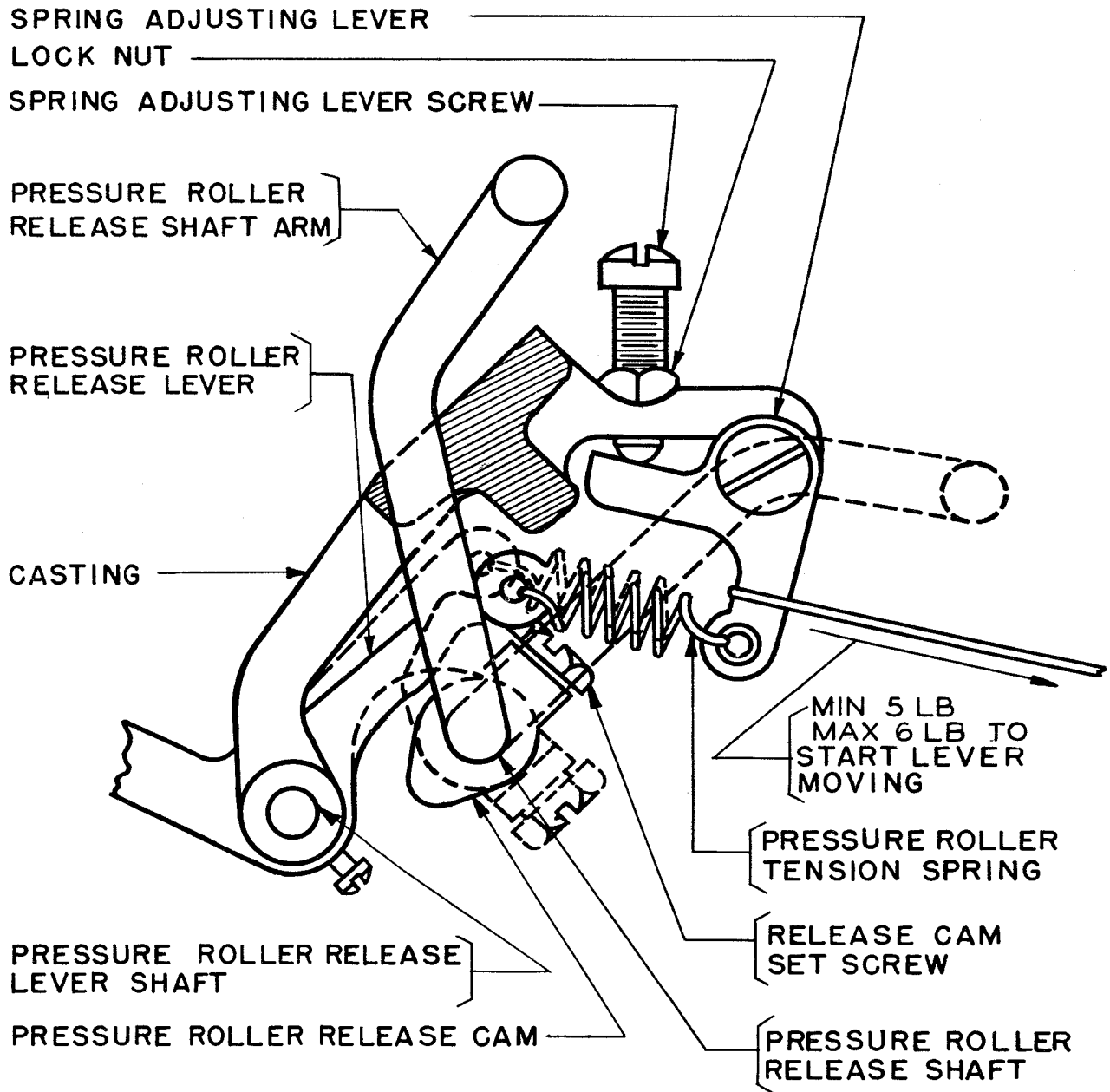

Figure 37

To Adjust: Reposition the paper-straightener-rod stops.

2.86 Paper-straightener-rod Springs should have a tension of minimum 8 ounces, maximum 12 ounces on the paper-straightener-rod levers. See Figure 39A.

2.87 Paper Guides: Outer sides of paper-guide discs should clear the shoulders on the paper-straightener rod by minimum 0.040 inch,

maximum 0.050 inch when 8-1/2-inch paper is used. For narrower paper, move the discs in correspondingly. See Figure 39B.

To Adjust: Reposition the paper-guide discs.

2.88 Rear-spacing-escapement Pawl should clear the low part of the spacing-escapement ratchet by minimum 0.020 inch, maximum 0.040 inch when the Line Feed combination is

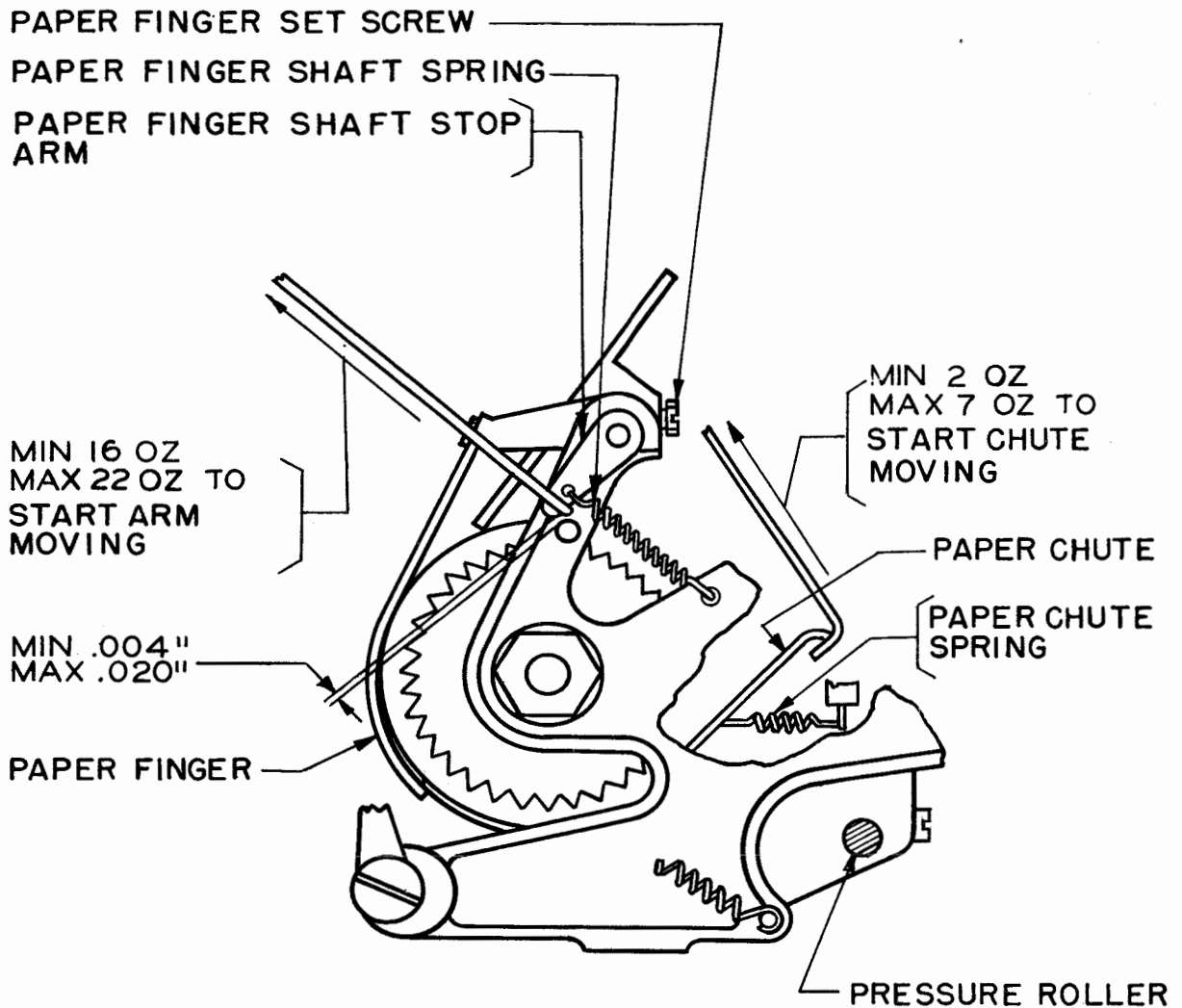

Figure 38

set up and the mainshaft is rotated until the function-lever bail rests on top of the line-feed function lever. See Figure 40.

To Adjust: Reposition the spacing-escapement-pawl operating arm.

Note: For machines arranged for horizontal tabulation with an adjustable front-spacing-escapement pawl to improve operation at 75 speed, refer to the section covering 15 teletypewriter, tabulator mechanism, transmitter-distributor control, and tabulator cut-out requirements and adjustments.

2.89 Spacing-escapement-pawl Spring: The spacing-escapement-pawl spring should have a tension of minimum 10 ounces, maximum 14 ounces when the mainshaft has been rotated until the printing bail is in its extreme rear position. See Figure 40.

2.90 Margin-bell Hammer should clear its bell by minimum 0.020 inch, maximum 0.060 inch when the hammer arm is resting against its stop-post. Gauge by eye. See Figure 41.

To Adjust: Loosen the margin-bell-hammer-bracket mounting screws and shift the bracket. If this does not give the required clearance, bend the bell-hammer arm along the entire length, avoiding a sharp bend at any point.

2.91 Margin-bell-hammer Spring should have a tension of minimum 10-1/2 ounces, maximum 13-1/2 ounces. See Figure 41.

SIGNAL BELL (2.92 through 2.98)

2.92 Signal-bell-hammer Spring on units so equipped, should have a tension of

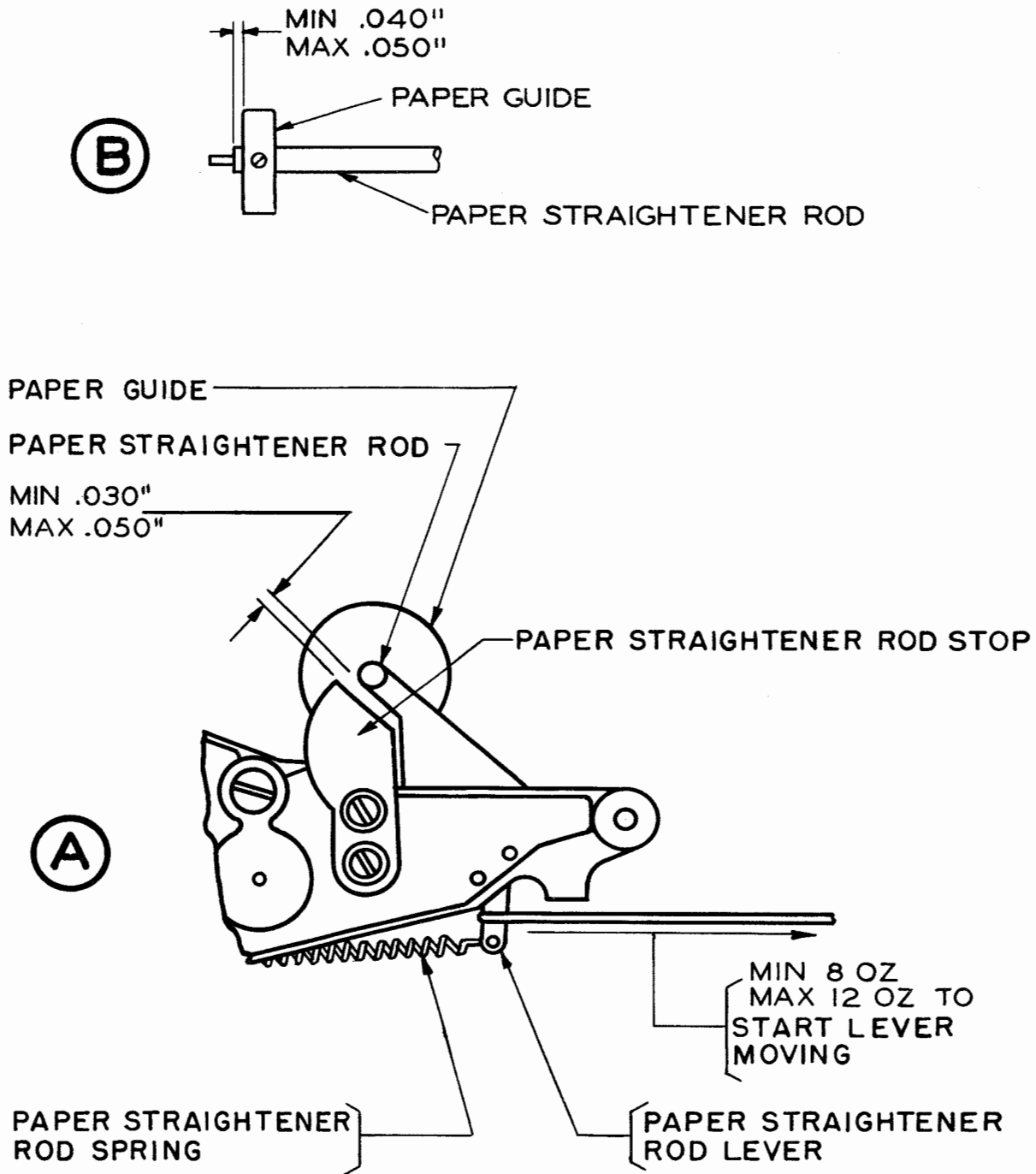

Figure 39

minimum 3 ounces, maximum 5 ounces when bell latchbar is in its latched position. See Figure 42.

Note: Place typing unit on its right side.

2.93 Signal-bell Latch-bar should clear the lobe on the bell-function-lever rear

extension by minimum 0.004 inch, maximum 0.010 inch when (1) the platen is in LTRS position, (2) the letter S combination is set up, (3) the mainshaft is rotated until the printing bail is in its extreme forward position, and (4) the front shoulder on bell latchbar is fully latched on latch. See Figure 43.

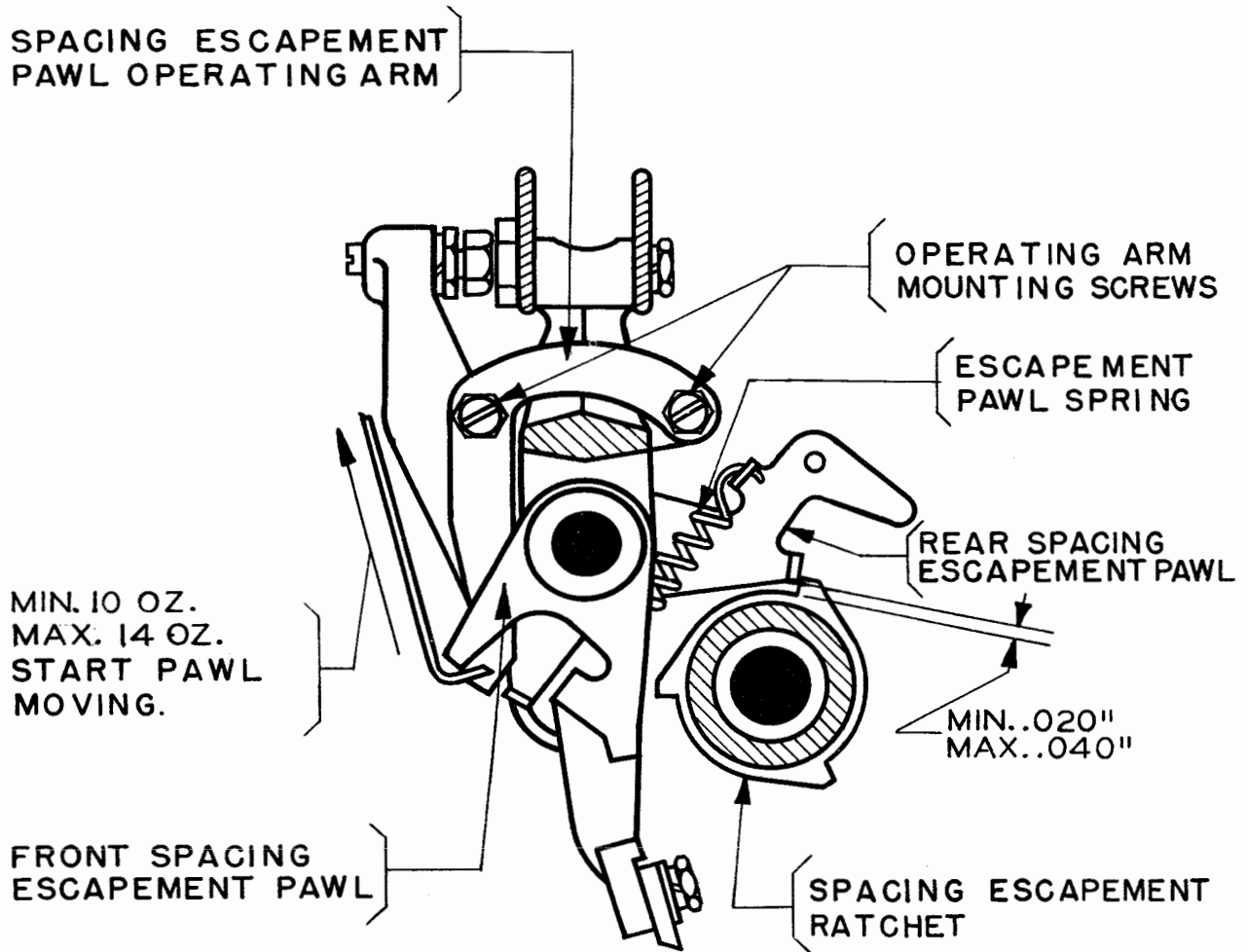

Figure 40

To Adjust: Add or remove shims between the bell latch-bar latch and the function lever comb.

2.94 Signal-bell Latchbar Latch: The signal-bell latchbar latch should clear the front shoulder on the bell latchbar by minimum 0.010 inch, maximum 0.020 inch when the mainshaft has been rotated until the function bail is in its extreme rear position and the bell-reset-bar shoulder is fully engaged with the function bail blade. See Figure 43.

To Adjust: Reposition the bell latchbar latch to the front or rear.

2.95 Signal-bell-hammer-arm Extension should clear the bell-operating lever by minimum 0.020 inch, maximum 0.040 inch when the bell latchbar is in its latched position. See Figure 42.

To Adjust: Reposition the bell-hammer backstop; see Figure 42 for the standard backstop.

2.96 Signal-bell Operating-lever Spring should have a tension of minimum 1-1/4 pounds, maximum 2-1/4 pounds when the bell-reset-bar spring is removed and the rear shoulder of the bell latchbar is resting against the bell-latchbar latch. See Figure 42.

2.97 Signal-bell Reset-bar Spring: The signal-bell reset-bar spring should have a tension of minimum 3 ounces, maximum 5 ounces when the mainshaft has been rotated until the function bail is in its extreme forward position and the front shoulder of the bell-latchbar is resting against the latch. See Figure 44.

2.98 Signal-bell Function-lever Spring should have a tension of minimum 1-3/4 pounds,

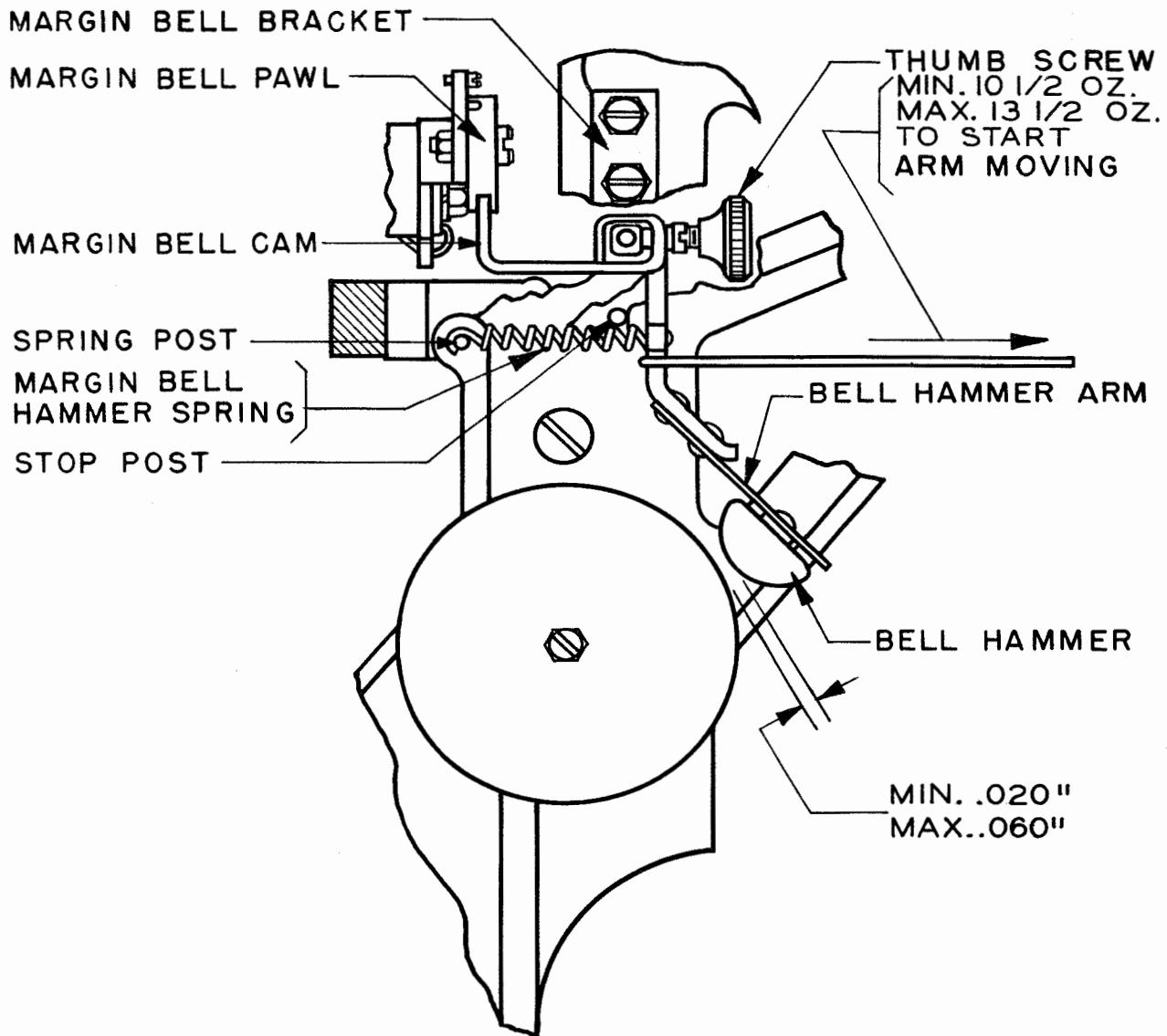

Figure 41

maximum 2-1/4 pounds when any character is selected and the mainshaft is rotated until the bell-function lever rests against the vanes but is not selected. See Figure 43.

CARRIAGE-RETURN MECHANISM ADJUSTMENTS (2.99 to 2.109).

2.99 Carriage-return Latchbar should clear the lobe on the carriage-return function-lever's rear extension by minimum 0.004 inch, maximum 0.010 inch when the letter O combination is selected, the mainshaft is rotated until printing bail is in its extreme forward position and the carriage-return latchbar shoulder is

fully latched on its latch. (See Figure 43 for similar adjustment of the signal-bell latchbar.)

To Adjust: Use shims between the carriage-return latchbar latch and function-lever comb. See Figure 45.

2.100 Carriage-return Latchbar Latch should clear the shoulder on the carriage-return latchbar by minimum 0.010 inch, maximum 0.020 inch when the mainshaft has been rotated until the function bail is in its extreme rear position and shoulder of carriage-return reset-bar is fully engaged with the function-bail blade.

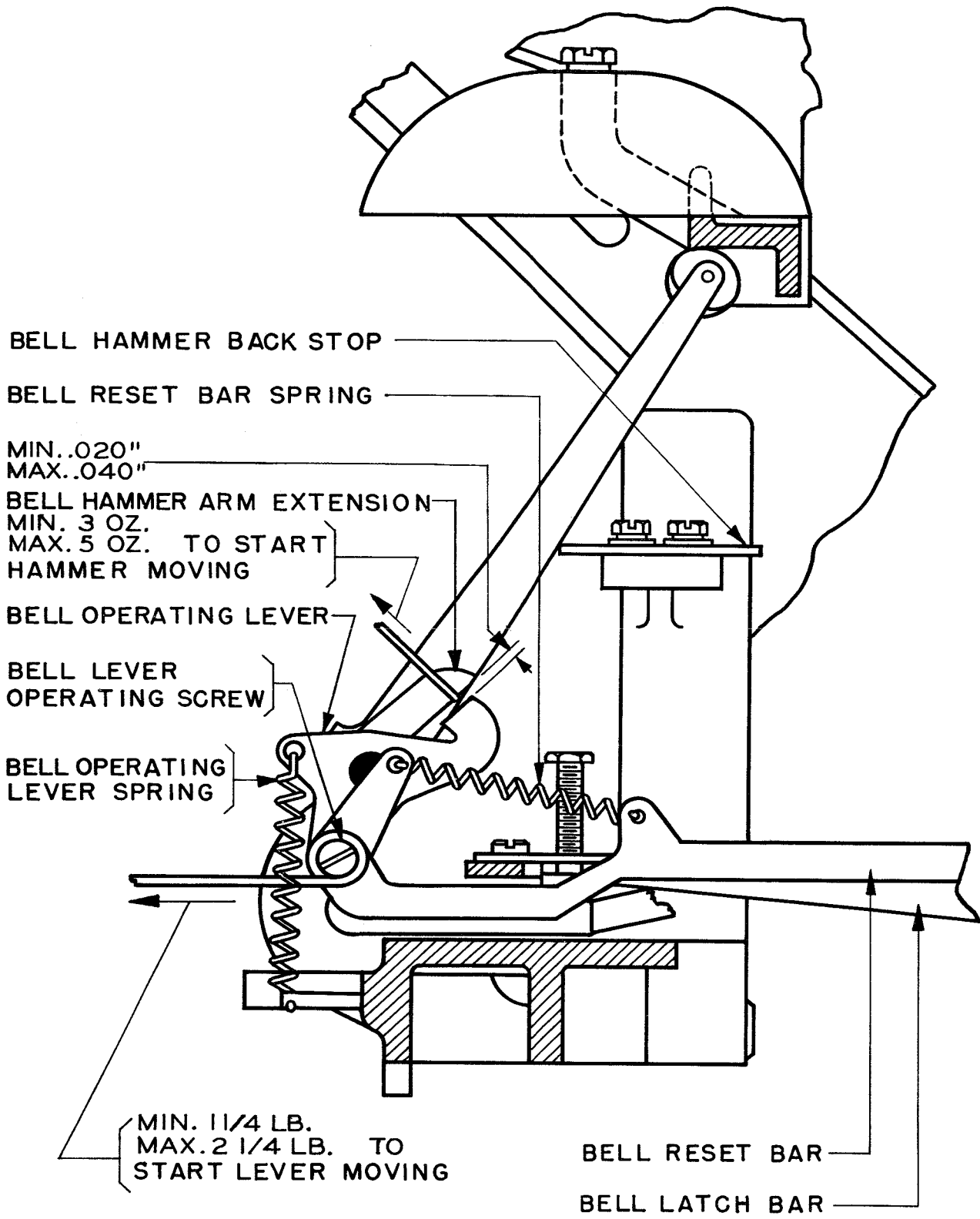

Figure 42

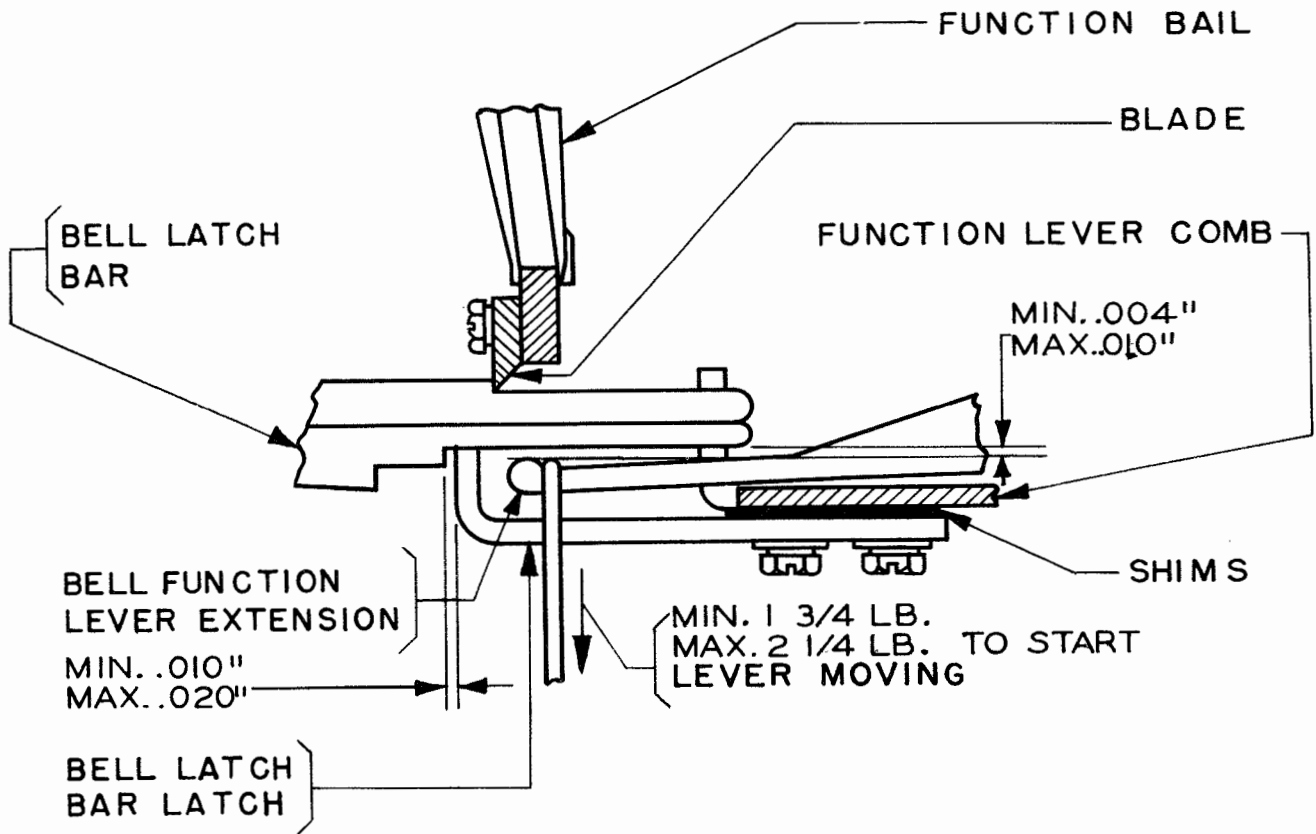

Figure 43

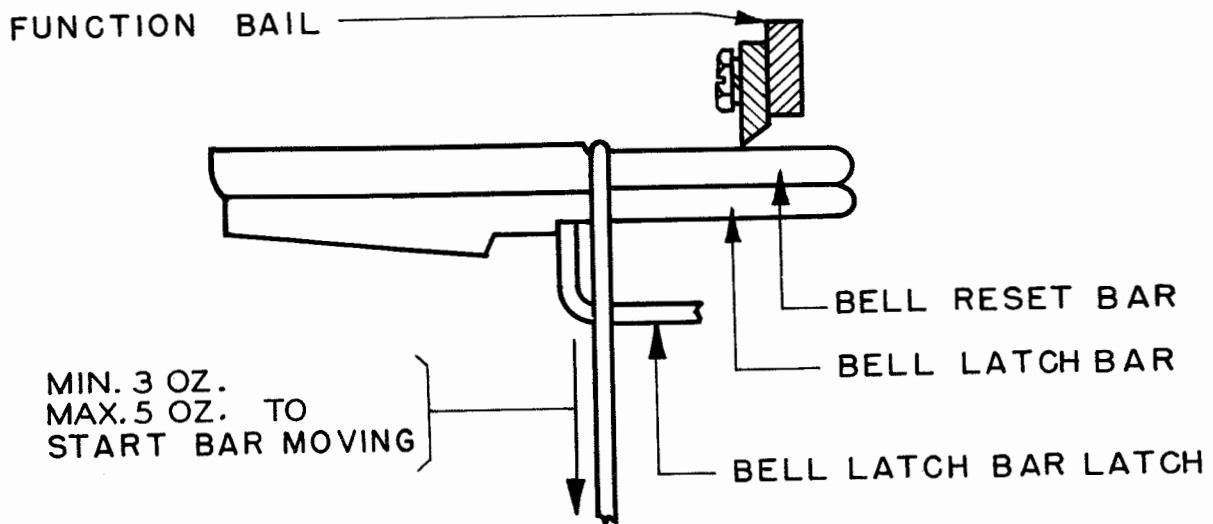

Figure 44

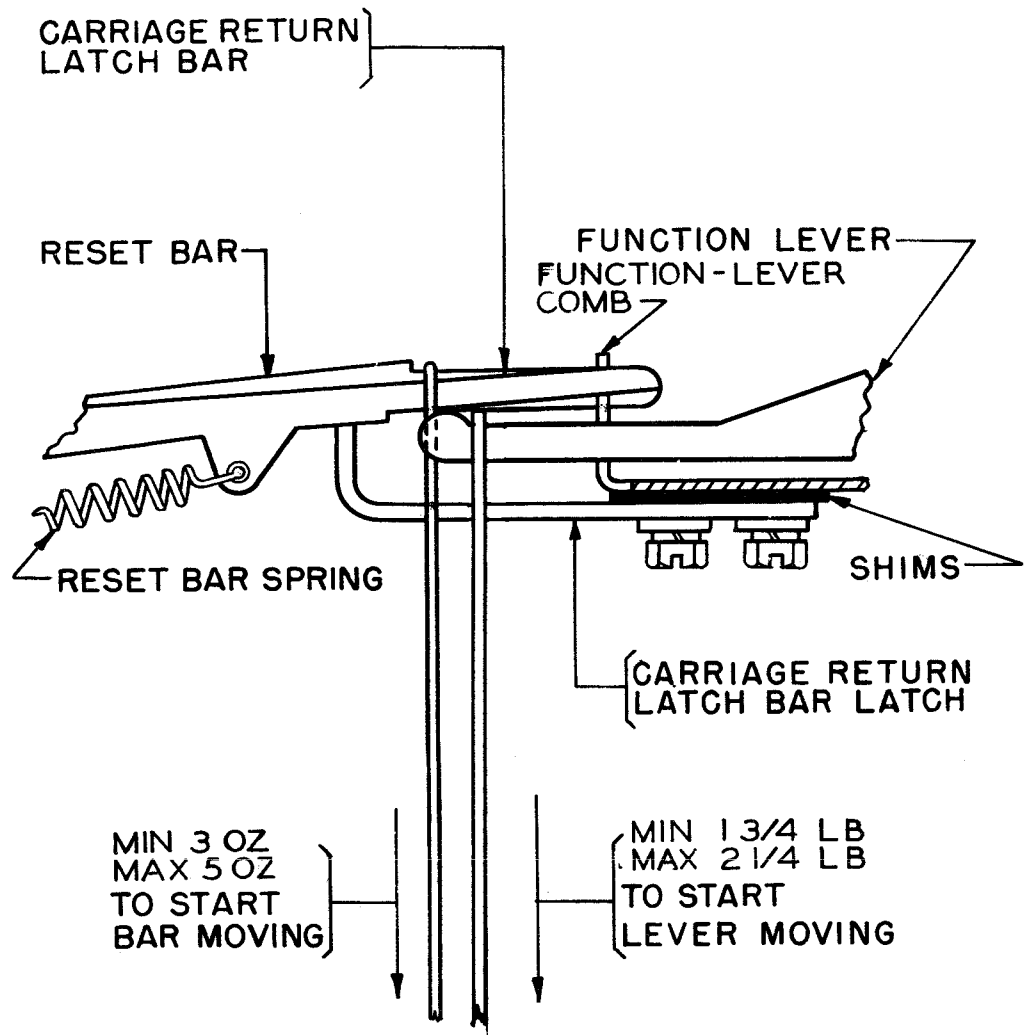

Figure 45

To Adjust: Reposition the carriage-return latchbar latch by means of its elongated mounting holes. See Figure 45.

Note: Place typing unit in its normal upright position.

2.101 Lock-bar Latch should clear the lockbar by minimum 0.006 inch, maximum 0.020 inch when the front end of the dashpot lever is held to its extreme left and play between the lockbar and the shoulder stud is taken up in a direction to make the clearance a minimum. See Figure 46.

To Adjust: Reposition the lock-bar-latch-eccentric screw.

Note: Use the position of the eccentric screw which will give the greater tension to the lock-bar-latch spring.

2.102 Lock-bar-latch Spring (new-style light spring) should have a tension of minimum 7 ounces, maximum 10 ounces when the carriage-return lock-bar latch is unlatched (resting on upper part of lockbar). (See Note, 2.101.) See Figure 46.

Note: Tension of old-style (short heavy) spring should be minimum 1-1/2 pounds, maximum 2-1/4 pounds, measured in same manner. New-style springs should be used when old-style springs require replacement.

2.103 Carriage-return Clutch: The teeth of the carriage-return clutch members should clear each other by minimum 0.010 inch, maximum 0.020 inch when the carriage-return lockbar is latched and the shoulder of lockbar is held against the edge of the latch. See Figure 47.

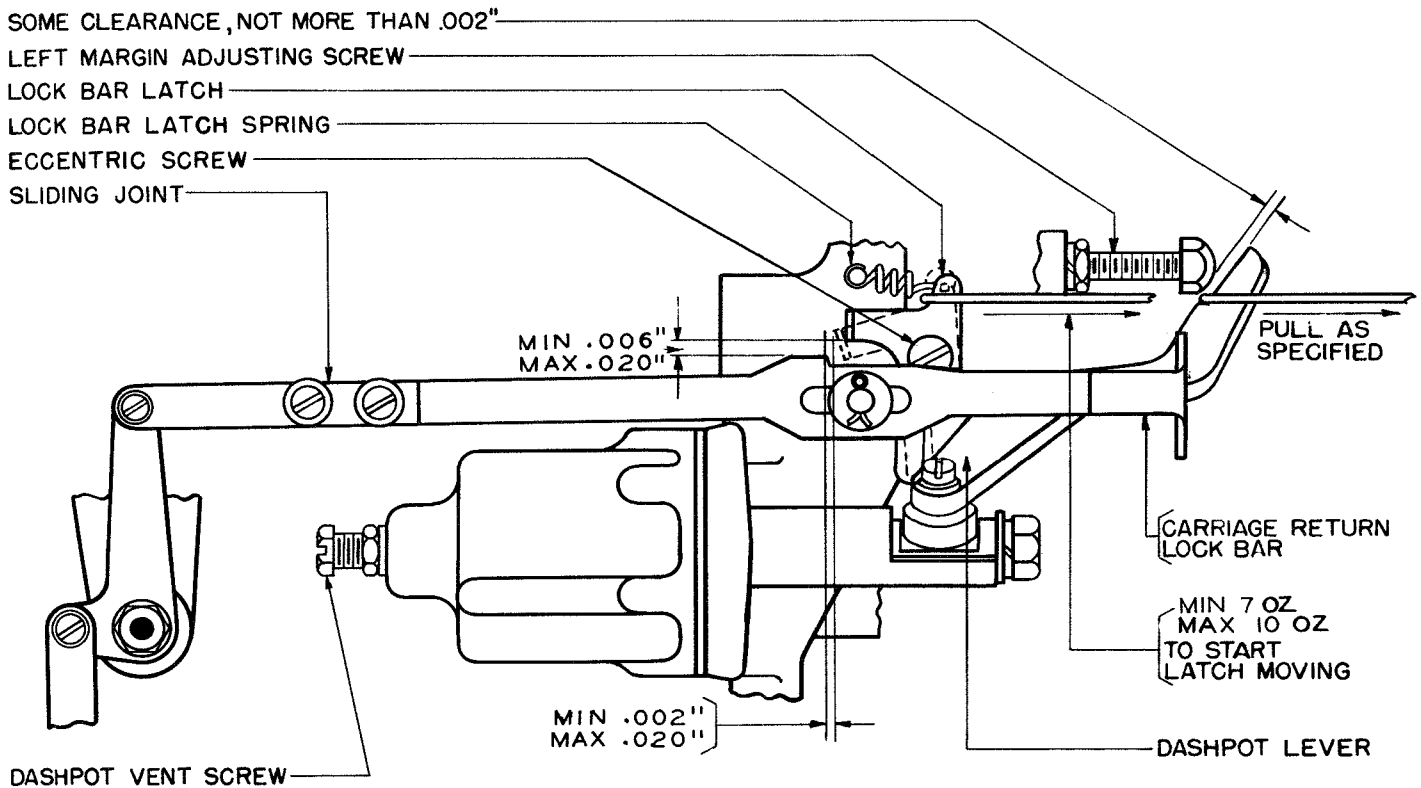

Figure 46

To Adjust: Loosen the lock-bar sliding-joint clamping screws and change the length of the lockbar. See Figure 46.

Note: Before readjusting, place the typing unit on its back, rotate the spacing shaft until the mounting screw of the driven-clutch member is accessible and operate the dashpot lever to engage the clutch teeth. Loosen the driven-clutch member mounting-screw and take up the play between the driven member and the mounting-screw by rotating the lower spacing gear in a clockwise direction viewed from the lower end of the shaft. Tighten the mounting-screw.

2.104 Carriage-return Operating-lever Stop Screw: Select the CAR RET combination and rotate the mainshaft until the carriage-return function lever just trips the carriage latch-bar off the latch. There should be a clearance of minimum 0.002 inch, maximum 0.020 inch between the latchbar shoulder and the inner edge of the lock-bar-latching lever.

Note: When making this adjustment all the play in the mechanism should be taken up in

a direction to make the clearance a minimum. This can be done by applying a scale on the lockbar and pulling and holding the lockbar outward with a tension of 6 ounces.

To Adjust: Set the height of the carriage-return operating-lever stop-screw. See Figures 46 and 47.

Note: Place typing unit on its right side.

2.105 Carriage-return Reset Bar Spring should have a tension of minimum 3 ounces, maximum 5 ounces, measured when the function bail is in its extreme forward position and the carriage-return latch-bar is tripped off its latch. See Figure 45.

2.106 Carriage-return Function-lever Spring should have a tension of minimum 1-3/4 pounds, maximum 2-1/4 pounds when any character combination is selected and the mainshaft is rotated until the carriage-return function lever is resting against the vanes but not selected. See Figure 45.

2.107 Carriage-return Operating-lever Spring (new style) should have a tension of

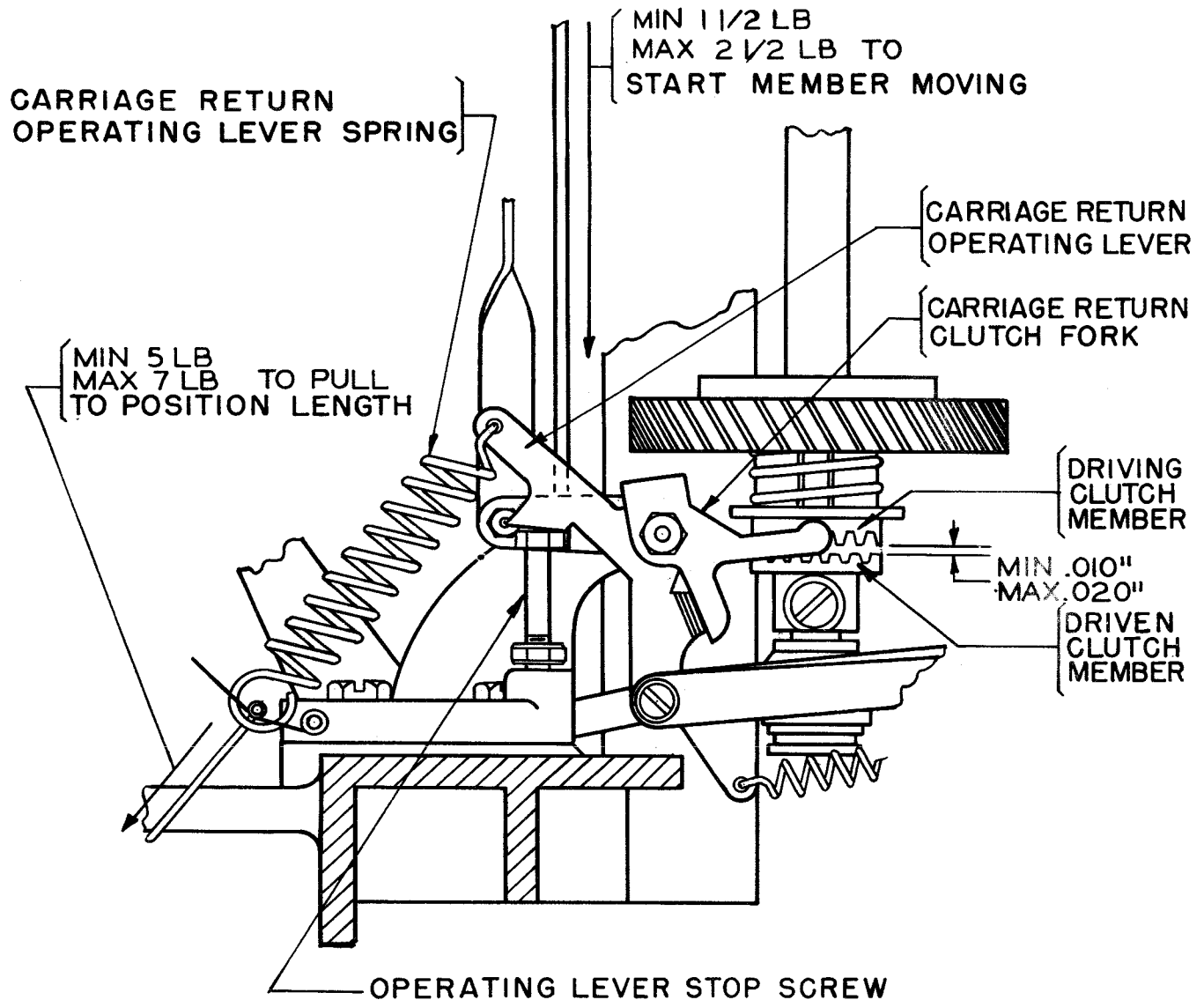

Figure 47

minimum 5 pounds, maximum 7 pounds when the shoulder of the carriage-return latchbar is against its latch. See Figure 47.

Note: Old-style springs had tension of minimum 7 pounds, maximum 10 pounds. New-style springs should be used when old-style springs require replacement.

2.108 Carriage-return Clutch Spring should have a tension of minimum 1-1/2 pounds, maximum 2-1/2 pounds, measured on the carriage-return clutch fork adjacent to the lock-bar link when the carriage-return latchbar shoulder is resting against its latch and

carriage-return lock-bar latch is held away from the lockbar. See Figure 47.

2.109 Dashpot-lever Spring should have a tension of minimum 16 ounces, maximum 22 ounces, measured when the front end of the dashpot lever is in the extreme right position and the spring is unhooked from the dashpot lever and stretched to position length.

2.110 Spacing-stop Lever should clear the mainshaft driving disc by minimum 0.060 inch, maximum 0.080 inch, and the right side of a spacing stop-sleeve tooth by minimum 0.040 inch, maximum 0.080 inch when the lever is

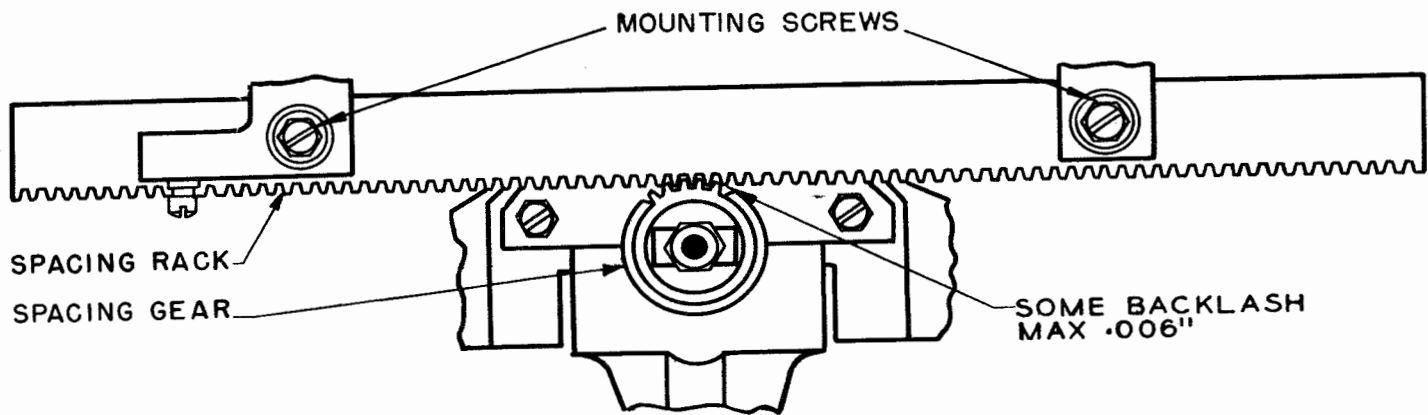

Figure 50

To Adjust: Remove one end of the draw strap and place it on the bell-hammer arm stop post, loosen the spacing rack mounting screws and position the rack toward the front or rear. Adjust with the carriage in its extreme left, right, and center positions. Retighten the screws and put back the draw strap.

2.115 Typebar Guide should clear the platen at its nearest point by $3/16$ inch $\pm 1/64$ inch gauged by eye, when the platen is in the LTRS position.

To Adjust: Use shims TP73427 between the typebar guide adapter plate and the typebar segment.

2.116 Locking-function-lever Spring should have a tension of minimum 40 ounces, maximum 50 ounces, measured when the mainshaft has been rotated until the printing bail is in its extreme rear position and the locking-function lever is held against its pivoting shaft. See Figure 28.

2.117 Sixth-vane Detent Spring should have a tension of minimum 6 ounces, maximum 8 ounces. See Figure 25.

2.118 Carriage-return Spring should have a tension of minimum $3-3/4$ pounds, maximum $4-1/4$ pounds, measured at the lower part of the right ribbon-spool bracket as the carriage starts to move from its extreme left position when (1) the mainshaft has been rotated until the printing bail is in extreme rear position, (2) the carriage-return lockbar is held in its latched position to disengage the clutch teeth, and

(3) the dashpot lever is held in its operated position. To increase the tension, turn the center shaft of the carriage-return-spring drum. To decrease the tension, operate the carriage-return-spring drum-escapement lever.

Note: Requirements 2.119 and 2.220 should be omitted on sprocket-feed typing units, which should be adjusted in accordance with the section covering the 15 teletypewriter sprocket feed mechanism.

2.119 Paper-spindle Drag-spring should have a tension of minimum 5 pounds, maximum 8 pounds, viewed from the rear of the typing unit when an empty paper spindle is locked in its slots with the retaining plates and both ends of the spindle shaft are resting in the bottom of their slots. See Figure 51.

To Adjust: Bend the spindle drag spring.

2.120 Platen-friction Assembly should require a pull of minimum 5 ounces, maximum 9 ounces to start the platen rotating when the pressure-roller-release shaft arm is in its extreme rear position, the line-feed detent-lever spring is unhooked, and the platen handle is placed vertically upward. See Figure 52.

To Adjust: Reposition the adjusting nuts of the friction assembly.

2.121 Send-receive T-lever Friction Washer on units equipped for double-blank break, should exert a drag of minimum 5 ounces, maximum $6-1/2$ ounces when the printing bail is in its extreme rear position and the T lever right arm has been positioned to clear the universal-

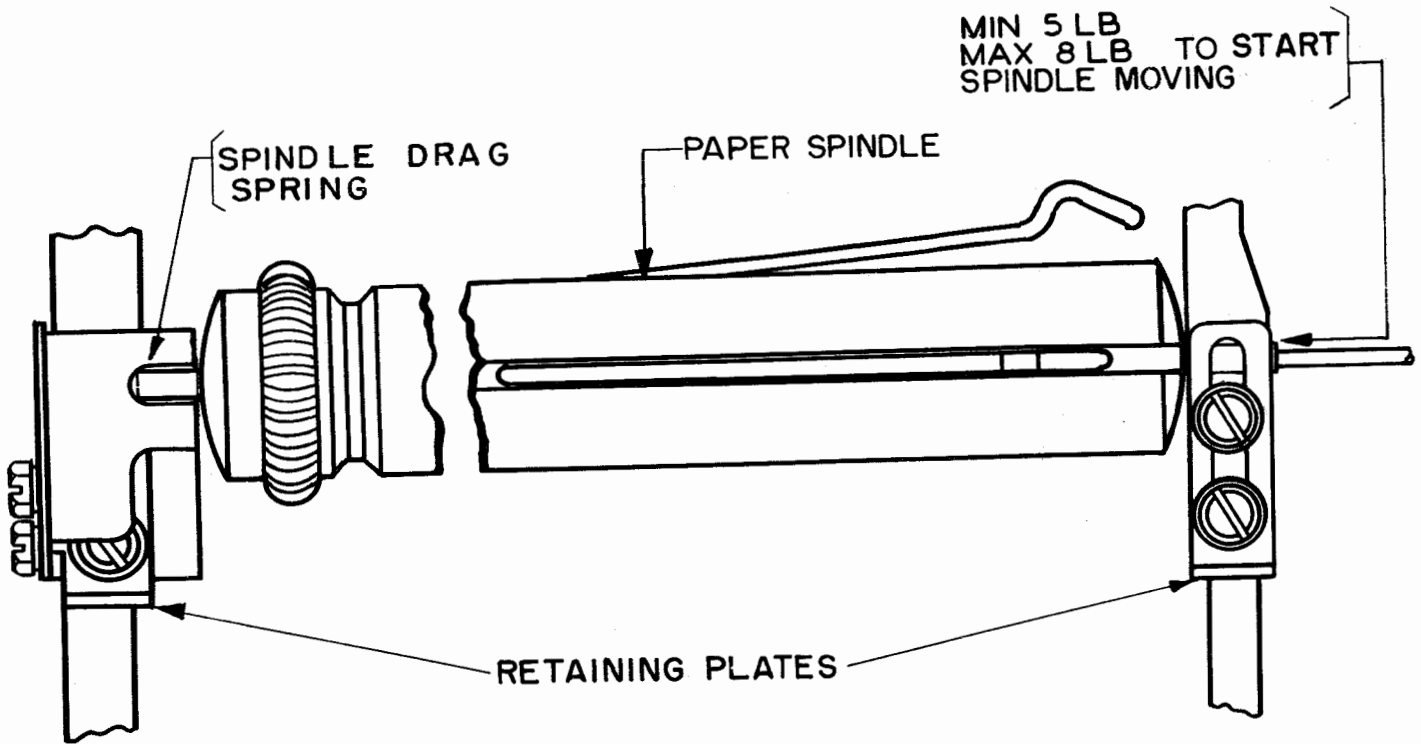

Figure 51

function-lever extension by minimum 0.040 inch, maximum 0.060 inch. See Figure 53.

To Adjust:

- (1) T-levers equipped with the TP3598 nut and TP2191 lock washer, clean the

friction surface free of oil and grease by wiping. Replace the friction washer if necessary.

- (2) T-levers equipped with the TP119925 elastic stopnut and TP71047 shim, reposition the stopnut.

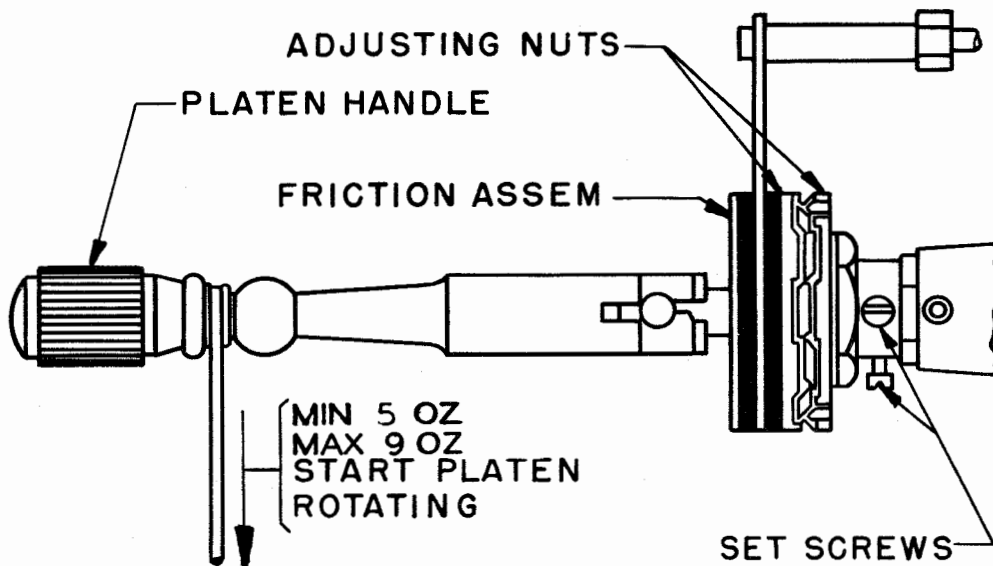

Figure 52

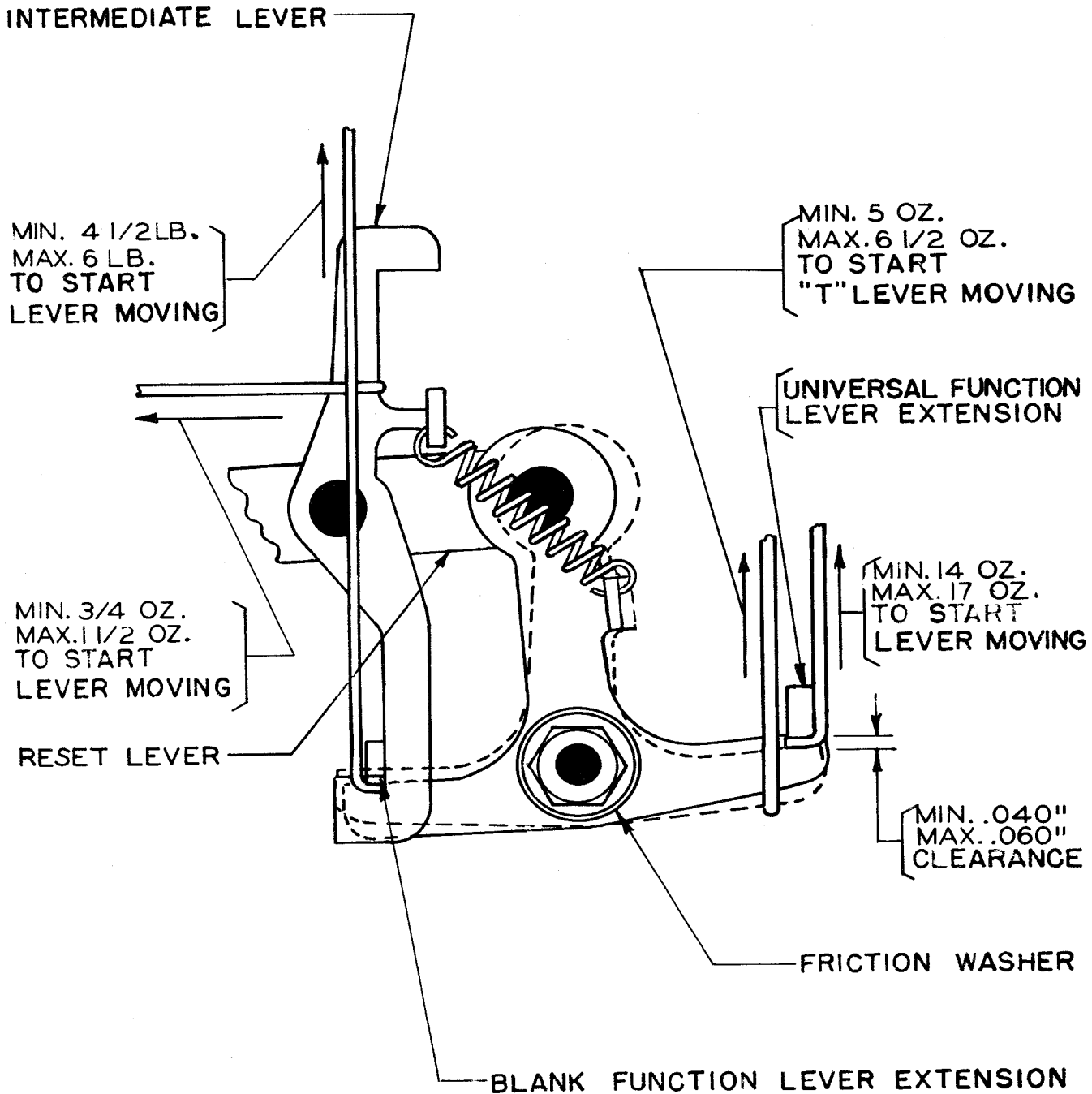

Figure 53

2.122 Universal-function-lever Spring should have a tension of minimum 14 ounces, maximum 17 ounces when the printing bail is in its extreme rear position. See Figure 53.

2.123 Blank-function-lever Spring should have a tension of minimum 4-1/2 pounds, maximum 6 pounds when the printing bail is in the extreme rear position. See Figure 53.

2.124 Send-receive T-Lever right arm, on units equipped with the double-blank break, should clear the universal-function-lever extension by not more than 0.008 inch. The required clearance should be measured when the left arm of the T-lever is in contact with the blank-function-lever extension, the blank combination is set up, and the mainshaft is rotated until the blank function-lever is

completely selected and the function-bail roller is just leaving the cam surface of the blank-function lever. See Figure 54.

Note: On typing units equipped with the blank printing-spacing cut-out function-lever, the mainshaft should be rotated until the function-lever bail rests on top of the blank printing-spacing cut-out function lever.

To Adjust: Reposition the send-receive mechanism plate by means of its elongated mounting holes. When making this adjustment, the intermediate lever should be clear of the blank-function-lever extension.

Note: Paragraphs 2. 125 and 2. 126 apply only to units equipped for single-blank break.

2. 125 Send-receive Mechanism Plate, on units not equipped with universal-function levers, should clear the function-lever spring-plate by minimum 0.020 inch, maximum 0.030 inch at both ends.

To Adjust: Reposition the send-receive-mechanism-mounting plate by means of its elongated holes.

2. 126 Blank-function Lever and No. 1 Vane:

The clearance between the blank-function lever and No. 1 vane or between the blank-function-lever extension and the T-lever should be maximum 0.002 inch, with the blank combination set up on the vanes, the intermediate lever held clear of the blank-function-lever extension, and the mainshaft rotated until the function-lever roller leaves the cam surface of

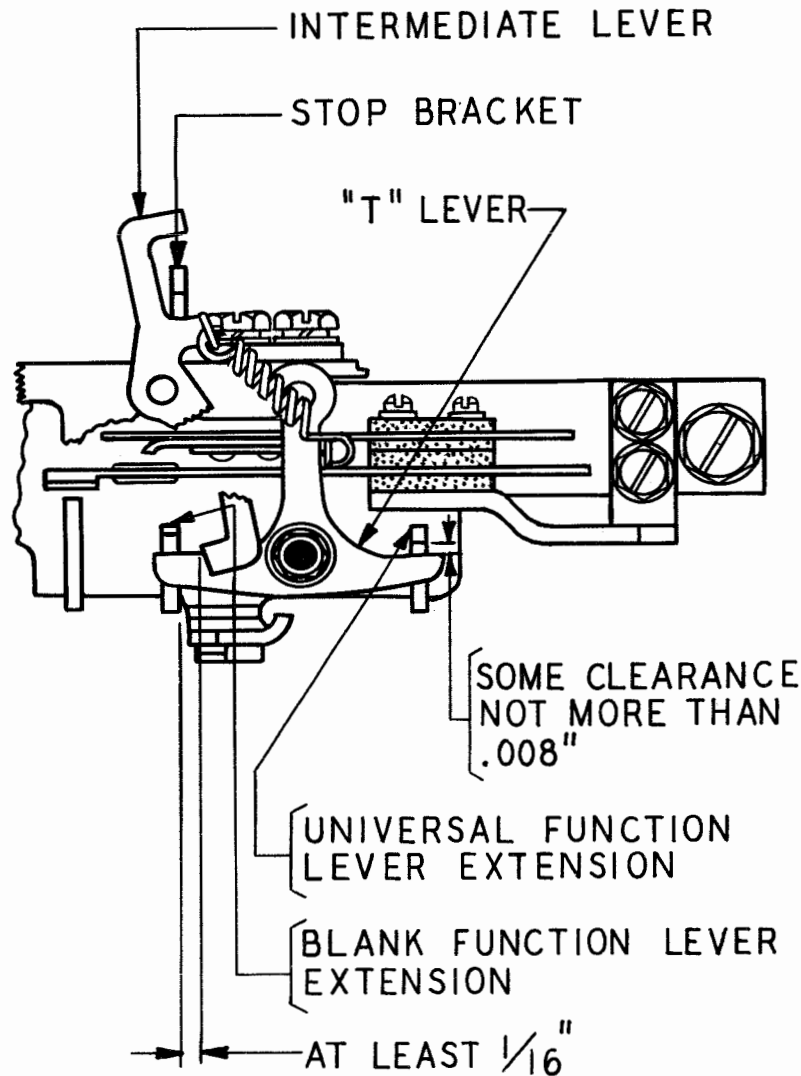

Figure 54

the blank-function lever, and under these conditions the blank-function lever should be in contact with either the No.1 vane or the T-lever, or both.

To Adjust: Loosen the T-lever clamping nut, set up the blank combination on the vanes, hold the intermediate lever clear of the blank-function lever, rotate the mainshaft until the function-lever roller leaves the cam surface of the blank-function lever, rotate the T-lever clockwise until it just touches the blank-function-lever extension and tighten the clamping nut.

Note: Paragraphs 2.127 and 2.128 do not apply when units are equipped with Single Blank Break.

2.127 Intermediate Lever should be approximately vertical, gauged by eye, when the blank combination is selected and the mainshaft is rotated until the intermediate-lever toe is under the blank-function-lever extension.

To Adjust: Reposition the intermediate-lever-stop bracket and check 2.126.

2.128 Intermediate-lever Toe: Left end of intermediate-lever toe should be to the right of the blank-function-lever extension by at least 1/16 inch when the letter T combination is set up and mainshaft is rotated until the printing bail is in its extreme forward position. Gauge by eye. See Figure 54.

To Adjust: Readjust the intermediate-lever stop-bracket and check 2.125.

2.129 Intermediate-lever Spring: It should require a tension of minimum 3/4 ounce, maximum 1-1/2 ounces to start the intermediate-lever moving when the printing bail is in its extreme rear position, the T-lever's right end is in contact with the universal-function-lever extension and the reset lever is held so that its upper edge is horizontal. See Figure 53.

To Gauge: Hook the scale on the intermediate lever just above the lug that holds the intermediate lever spring as indicated in the figure. Pull at right angles to the intermediate lever.

Note: Put the typing unit back on the base.

2.130 Send-receive Reset-lever Upper Adjusting-screw:

(a) Units Equipped with Double Blank Break (Units with Universal Function-lever): The upper edge of the intermediate-lever toe should clear the blank-function-lever extension by minimum 0.004 inch, maximum 0.006 inch when (1) the printing bail is in the extreme rear position, (2) the send-receive-break lever is in the send (up) position, (3) the intermediate-lever toe is moved under the blank function lever, (4) the T-combination is set up, and (5) the motor is rotated until the blank function-lever overlaps the toe of the intermediate lever by half the thickness of the blank function-lever. See Figure 55.

To Adjust: Reposition the reset-lever upper adjusting-screw.

(b) Units Equipped with Single Blank Break (Units Where Universal Function-lever is Omitted): The upper edge of the intermediate-lever toe should clear the blank-function-lever extension by minimum 0.004 inch, maximum 0.006 inch when (1) the send-receive-break lever is in the send (up) position, (2) the intermediate-lever toe is under the blank function-lever, (3) the T-combination is set up, (4) and the motor is rotated until the function-lever roller leaves the cam surface of the blank function-lever.

To Adjust: Reposition the reset-lever upper adjusting screw.

2.131 Send-receive Reset-lever Lower Adjusting-screw should clear the motor-stop-function lever's front extension by not more than 0.002 inch when (1) the platen is in the LTRS position, (2) the motor stop combination is selected, (3) the motor is rotated until the printing bail is in its extreme forward position, and (4) the send-receive lever is in the send position. See Figure 56.

Note: This requirement applies only to units equipped with mechanical motor-stop mechanism.

To Adjust: Reposition the reset-lever lower adjusting screw.

2.132 Send-receive Reset-lever Down-stop Screw: The upper contact lever or the operating lever of the send-receive-break mechanism of the associated base should over-travel the latching surface of the stop-lever plate by not more than 0.002 inch; gauged by eye, when (1) the send-receive lever or handle

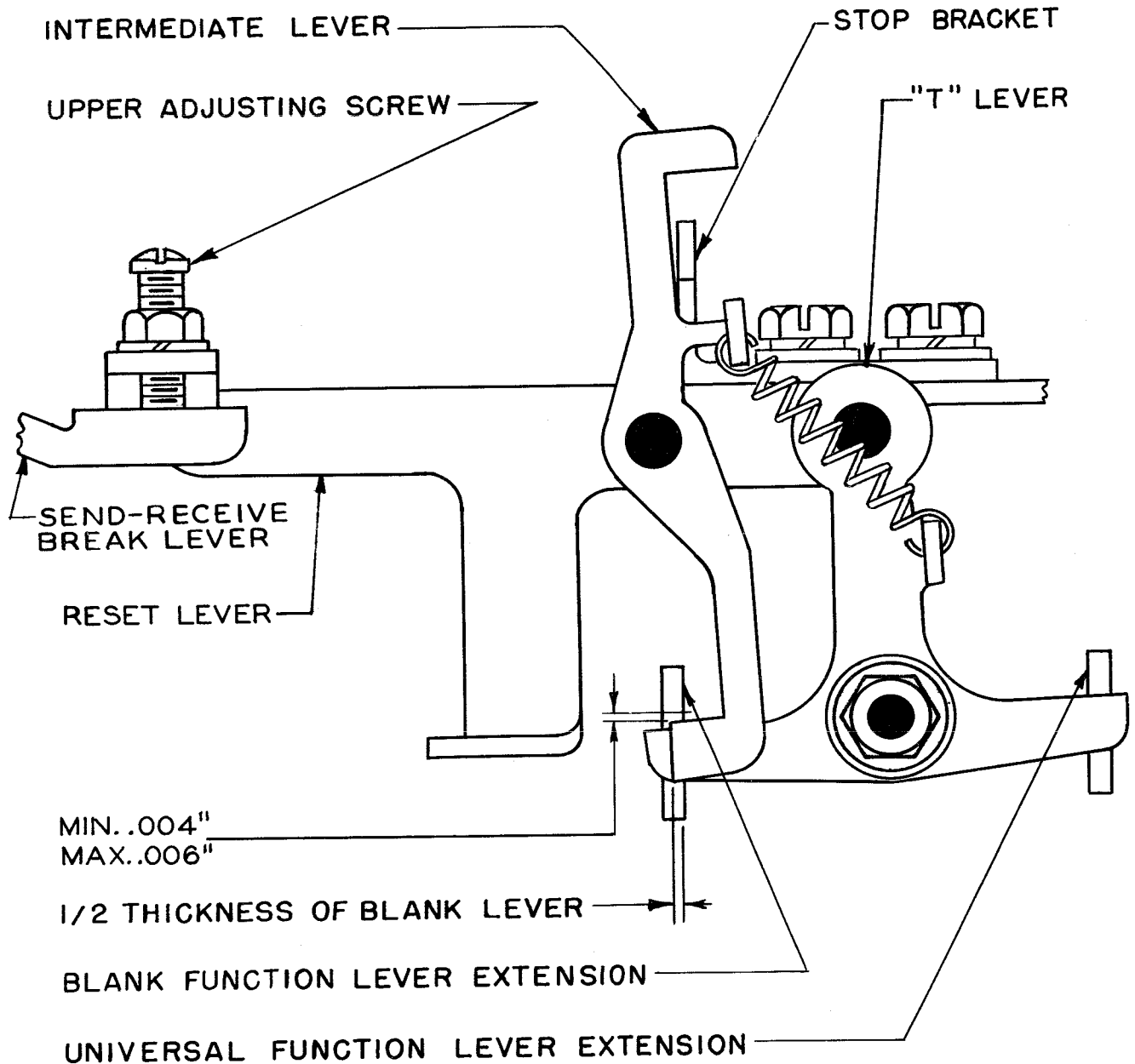

Figure 55

is in the send position, (2) the intermediate-lever toe is under the blank function-lever extension, (3) the blank combination is set up, (4) the mainshaft is rotated until the function-bail roller just leaves the cam surface of the blank-function lever, and (5) the send-receive-break-mechanism break-lever (key) is depressed and immediately released. See Figure 57.

Note: On old-style send-receive-break mechanism having single set upper-break contact springs, upper contact-lever (or operating

lever) should overtravel the latching surface of the stop-lug on the safety pawl by not more than 0.002 inch.

To Adjust: Reposition the send-receive reset-lever downstop-screw.

2.133 **Left Margin:** First character of a line should be typed within 1/16 inch of the specified margin, normally 7/8 inch from the platen's left end. Gauge by eye.

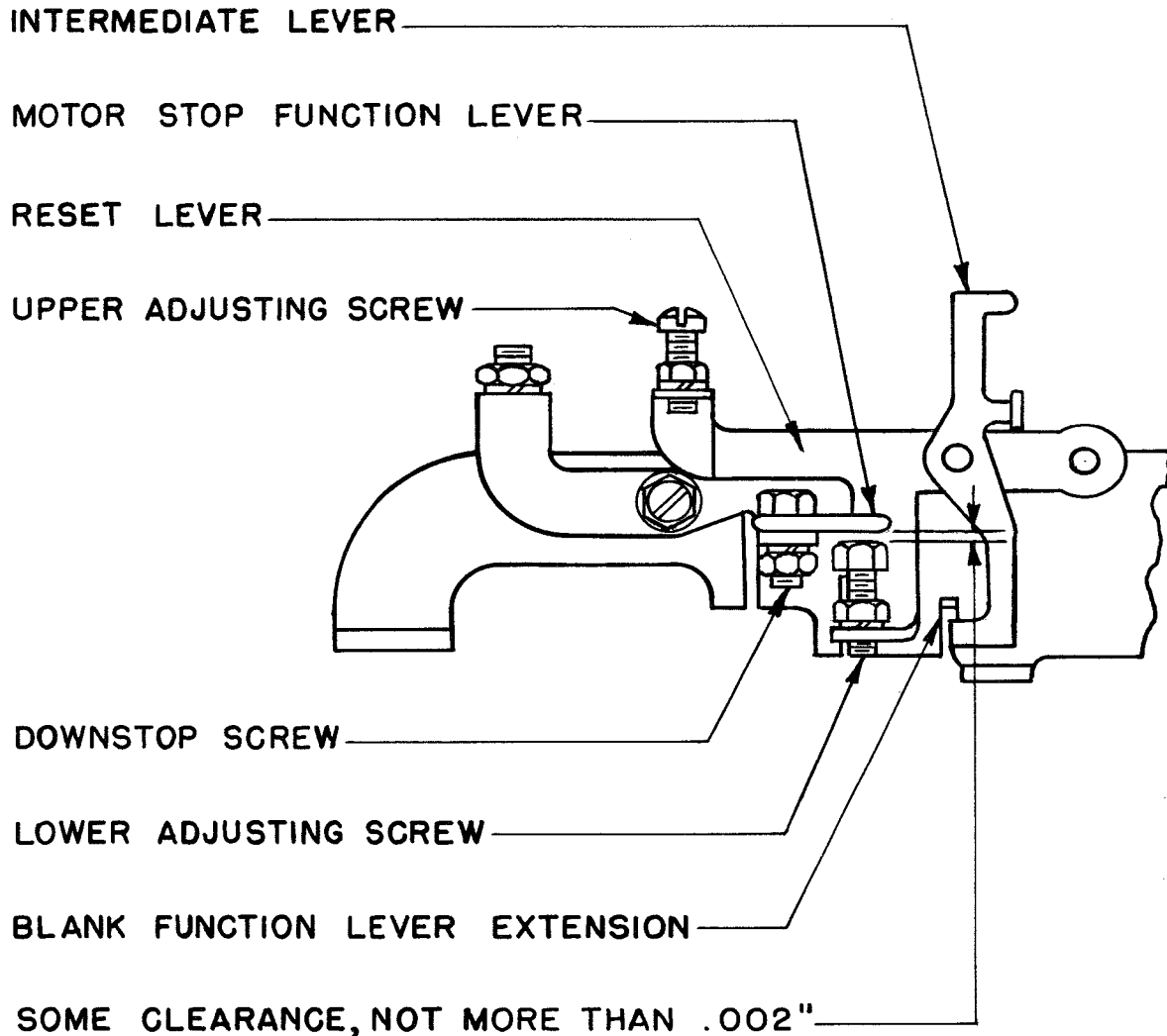

Figure 56

Note: Sprocket-feed typing units should be adjusted in accordance with the section covering the 15 teletypewriter sprocket-feed mechanism.

To Adjust: Place the carriage in position to print a character within 1/16 inch of the specified margin and lock the carriage by operating the dashpot lever, check to see that the carriage-return clutch is fully engaged, reposition the left-margin adjusting screw until it clears the dashpot lever by not more than 0.002 inch when an 8-pound pull is exerted on the dashpot lever at right angles to the curved surface 1/32 inch behind the margin-adjusting screw when the adjusting-screw locknut is slightly tightened to take up the endplay in the threads,

then turn the adjusting screw 1/6 turn in direction to eliminate this clearance. See Figure 58.

Note: The above applies to units having the new-style dashpot levers. On units equipped with old-style levers having a shoulder to the rear of the margin-adjusting screw, a 10-pound pull instead of 8 as above should be applied at right angles to the surface of the lever just in front of the shoulder when making the adjustment.

2.134 **Right Margin:** The spacing-stop-pawl arm should clear the spacing-stopsleeve projection by minimum 0.015 inch, maximum 0.030 inch when the right-margin adjusting-screw arm is in normal engagement with its

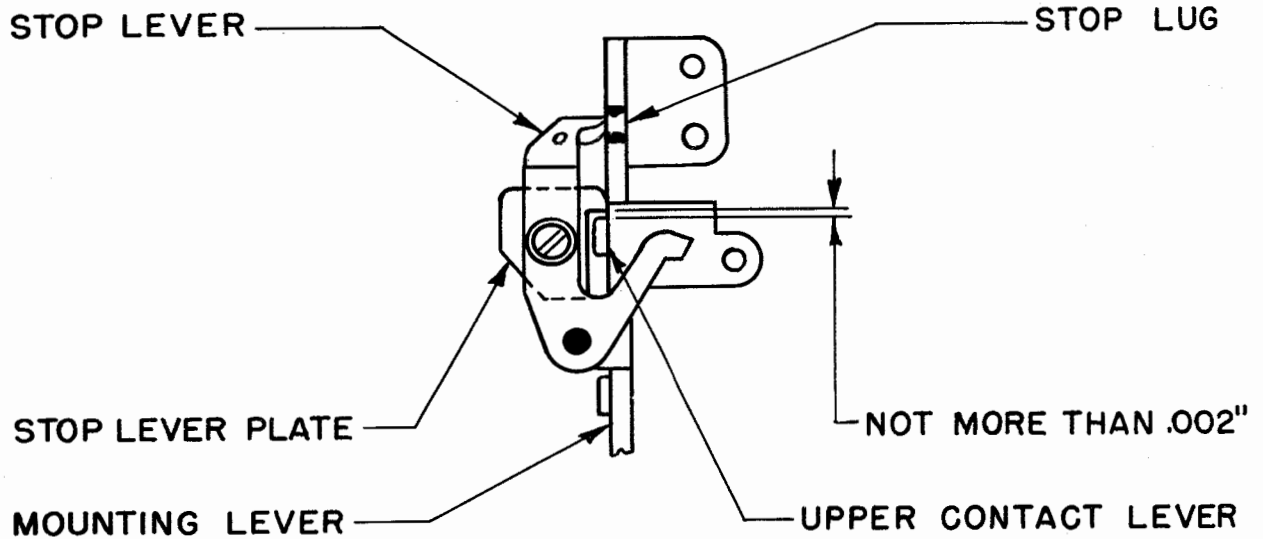

Figure 57

detent and the carriage in position to type the last character of the line. See Figure 59.

Note: This does not apply to units equipped with the TP92784 set of parts for suppressing typing and spacing at the end of a line.

To Adjust: Reposition the right margin adjusting screw and check to see that excess characters at the end of the line partially overtype the last character, that is, that

the 73rd character M partially overtypes the 72nd character M of a 72-character line.

Note: To obtain more characters per line (73 to approximately 80) adjust either the right or the left-hand, or both margin-adjusting screws.

2.135 **Ribbon-oscillator Lever:** The top of the letter T should strike the ribbon approximately 1/16 inch below the top edge of the

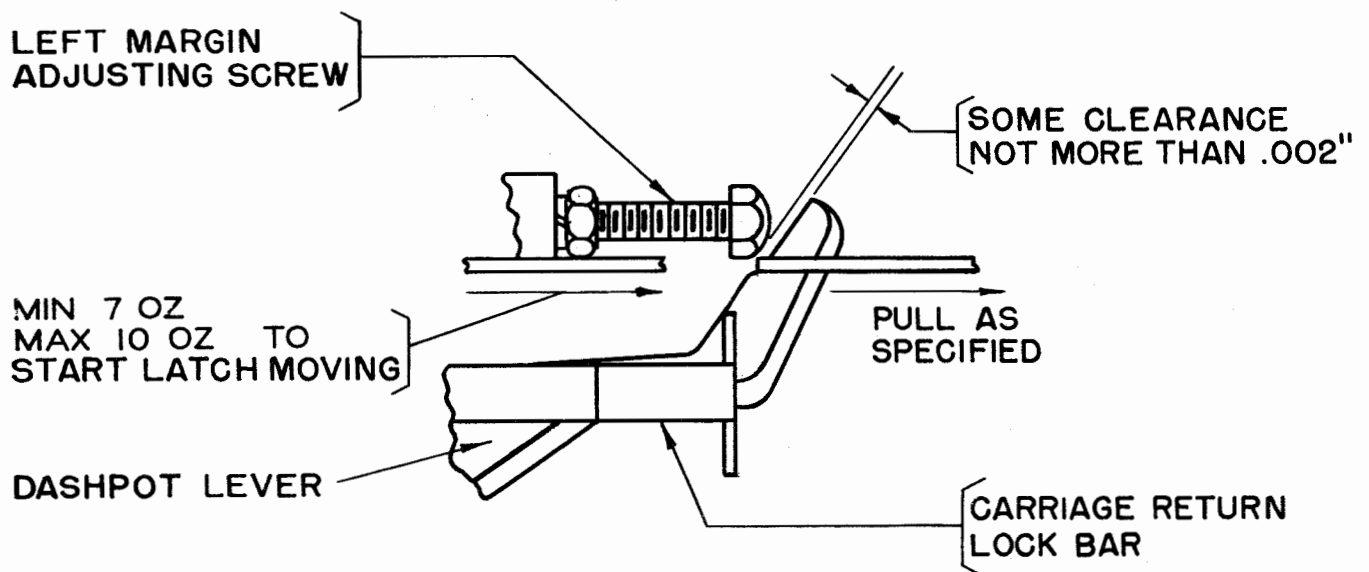

Figure 58

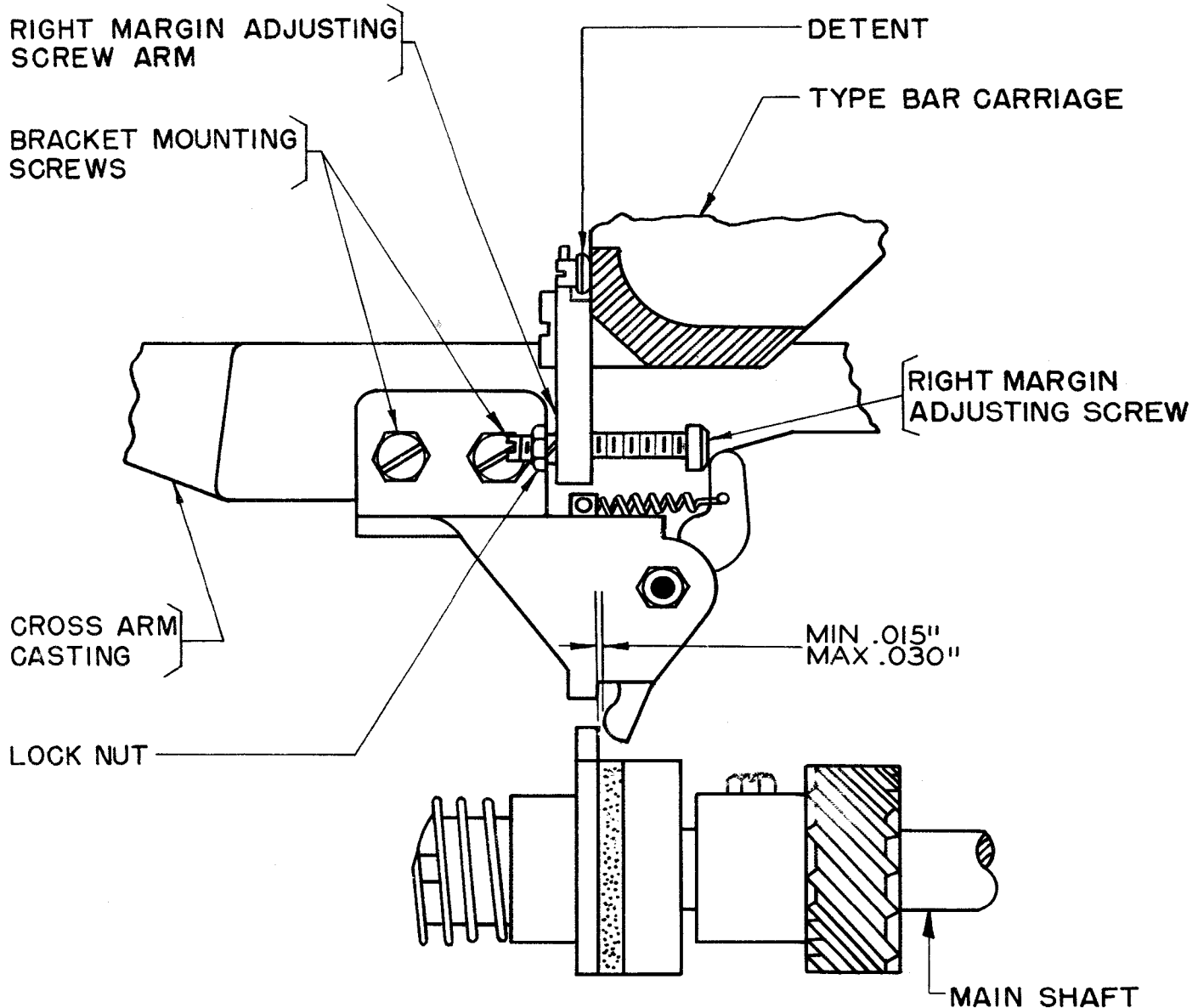

Figure 59

ribbon when: (1) the platen is in the LTRS position, (2) the T combination is set up, (3) the mainshaft is rotated until the function bail is in its extreme forward position, (4) the T typebar is raised manually until it engages the ribbon. Gauge by eye and use the height of the letter T, which is approximately 1/8 inch, as a guide.

Note: If large fraction typepallets are provided, check the printing in upper case to insure that the ribbon covers the face of all fraction typepallets.

To Adjust: Shift the platen to the FIGS (up) position, loosen the ribbon-oscillator-lever clamping screw and nut, and reposition the oscillator up or down. See Figure 60.

Note: 2.136 and 2.137 apply only to units equipped with adjustable ribbon-lockout lever.

2.136 Ribbon-lockout Lever: The ribbon should be locked sufficiently below the printing line to prevent printing any portion of a character when the lockout-lever is moved to the left against its stop.

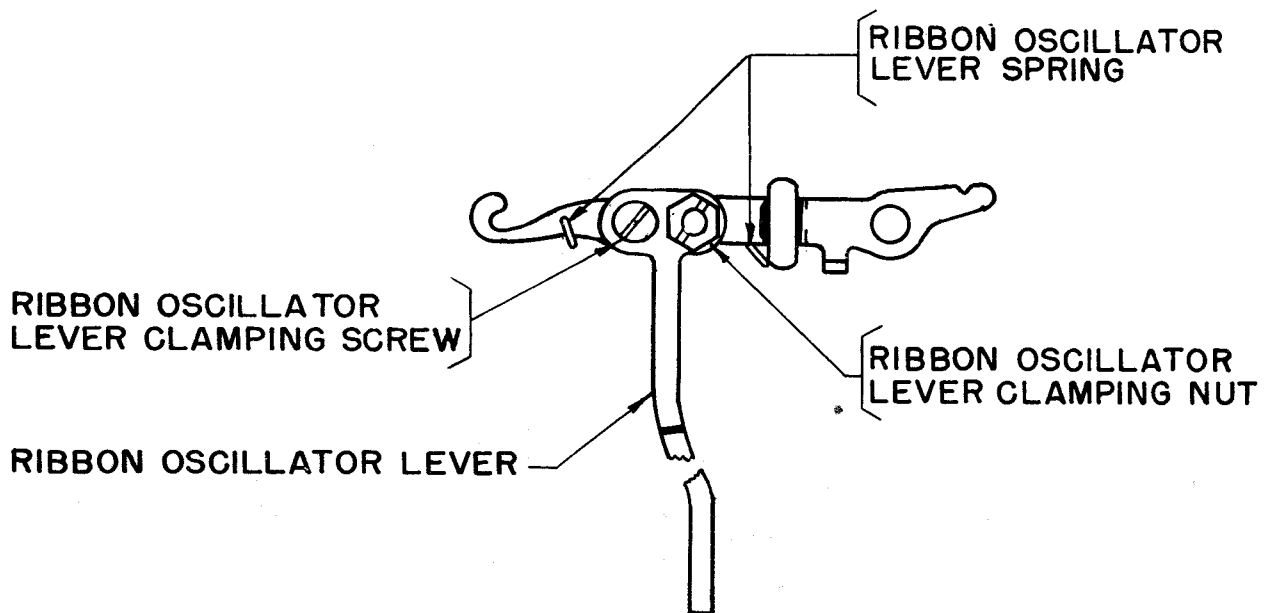

Figure 60

To Adjust: Remove the ribbon, the ribbon-carrier and the typebar guide from its adapter plate, and loosen the ribbon-lockout-lever adjusting-screw; move the platen to the FIGS position; hold the ribbon oscillator down and move the lockout lever to the left against its stop, sliding the lockout-lever extension over the top of the oscillator; push the lockout-lever extension down so that the oscillator is held firmly against the typebar guide-adapter plate and at the same time hold the right end of the lockout lever down; tighten the lockout-lever adjusting screws and reassemble the type lever guide, the ribbon carrier, and the ribbon.

2.137 Ribbon-lockout Lever should require a pull of not more than 5 pounds to move the lever to its unoperated position. See Figure 61.

2.138 Spacing-clutch Torque: After the motor has run for at least 10 minutes, a pull of minimum 18 ounces, maximum 24 ounces, applied to the spacing-escapement-ratchet tooth horizontally toward the rear of the typing unit should be required to hold the ratchet stationary with the motor running, the carriage-return lockbar tied in the latched position (carriage free to move) and the rear spacing-escapement pawl held clear of the ratchet. See Figure 62.

Note: On typing units equipped with the old-style TP113763 set of parts to give 6 characters per inch (horizontally), the regular standard adjustments should be made, except that the torque of the spacing clutch should be increased slightly above that normally used. A torque of 20 to 26 ounces should be used instead of 18 to 24 ounces.

2.139 Margin Bell should ring when the carriage is 6 characters from the end of the line, unless otherwise specified.

To Adjust: Position the carriage 6 characters from the end of the line and reposition the margin bell cam until its right side is in contact with the margin bell pawl. See Figure 41.

2.140 Bail-cam-unit Friction-clutch Torque: After the motor has run for at least 10 minutes, a pull of minimum 20 ounces, maximum 24 ounces, applied horizontally to the screw head on the bail-cam should move the cam in a direction opposite the normal rotation, when the motor is running, the function-bail spring is removed and the printing bail is held away from its adjusting screw.

Note: This measurement requires considerable care and need be checked only when it is thought that the cam is not being brought up to speed as the clutch engages.

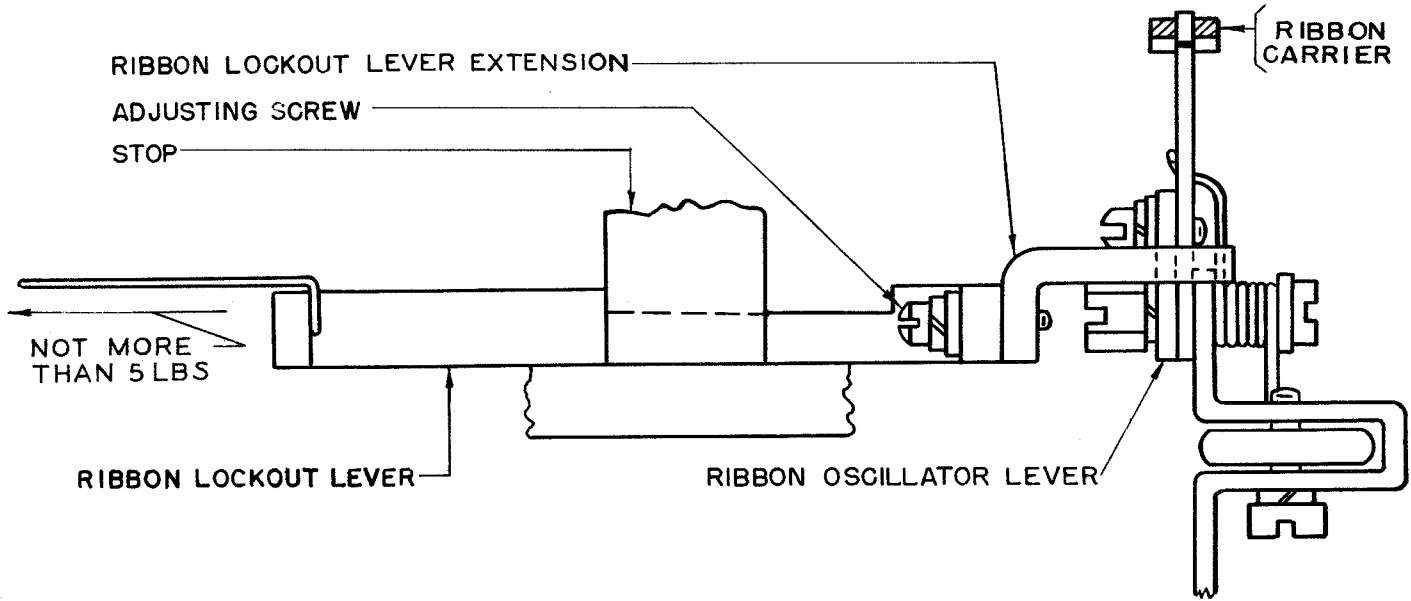

Figure 61

To Check: Hold the printing bail away from its adjusting screw, block the magnet armature in the operated position so the main clutch will not engage, hook a scale over the screw and pull in a direction reverse to normal rotation until the cam unit just starts to move.

CLUTCH ENGAGING AND WINDING THE SCALE AROUND THE MAINSHAFT, SO EITHER KEEP THE ARMATURE OPERATED TO AVOID TRIPPING THE CLUTCH STOP-ARM, OR BLOCK OR CLAMP THE CLUTCH STOP-ARM SO THAT THE MAIN CLUTCH CANNOT ENGAGE.

Note: Pulling too far will tend to make the main clutch engage and give a greater reading, therefore only a slight backward motion of the cam should be given.

To Adjust: Replace the compression spring and the felt washer of the clutch. If the torque is too high, lubricate the clutch and recheck it before replacing the parts. See Figure 63.

CAUTION: IT IS IMPORTANT TO KEEP THE CLUTCH STOP-ARM AGAINST THE DRIVEN JAW TO PREVENT THE MAIN

2.141 Dashpot-vent Screw: The carriage should return from its extreme right position

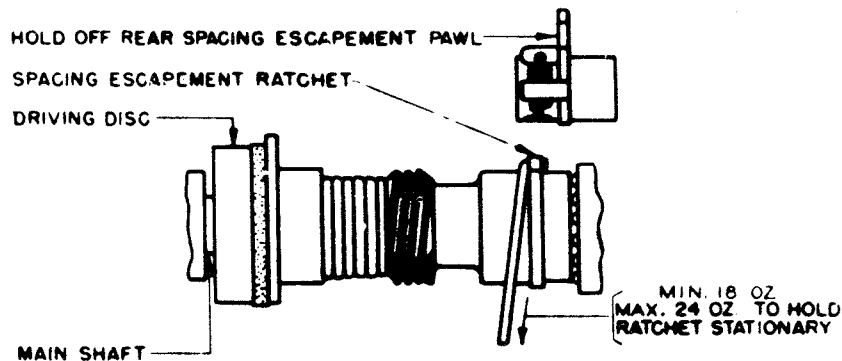

Figure 62

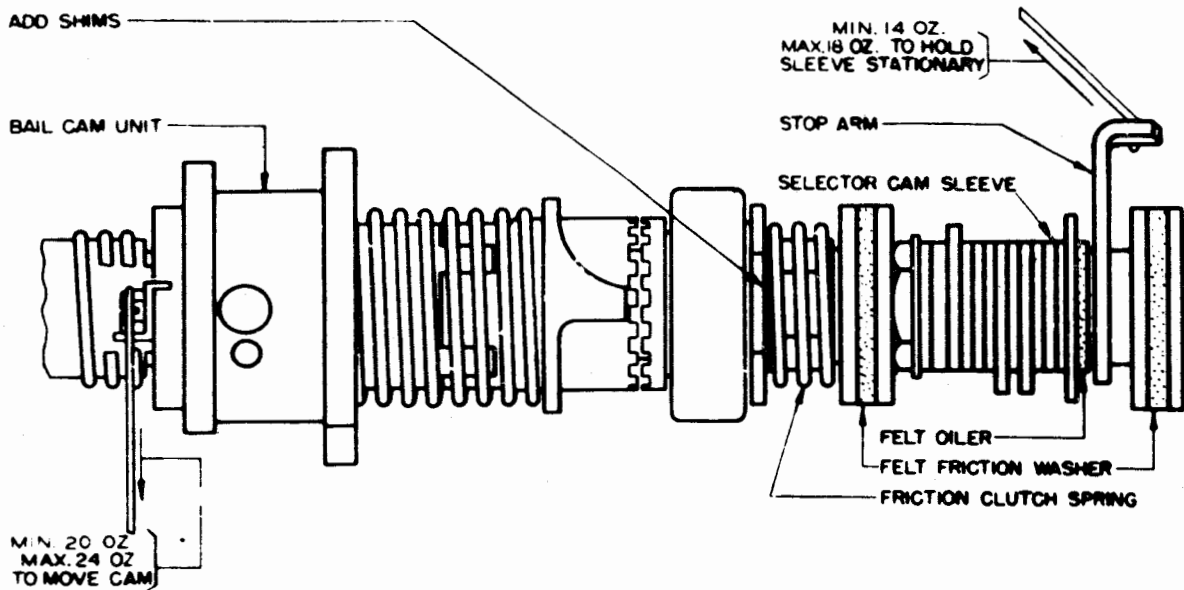

Figure 63

with minimum shock without bouncing when the carriage-return lock bar is held in its latched position.

To Adjust: Reposition the dashpot-vent screw. If proper operation of the carriage cannot be obtained by adjustment of the screw, replace the dashpot leather washer.

2.142 Typebars and Pullbars should move freely and not bind in the type-segment slots as gauged by feel.

To Adjust: Clean and if necessary stone down with the TP87698 carborundum stone the section which fits in the slot.

2.143 Typebar Toes should be straight and approximately in line with the type pallet and should enter the typebar guide freely without bind as gauged by feel.

To Adjust: Loosen the typebar-guide adapter-plate mounting screws and reposition the plate so that the Z and V typebars enter the guide freely, bend the toes of the other typebars so they enter the guide freely. If necessary, adjust the opening of the guide by bending to just take the thickest typebar without bind and the thinnest typebar with not more than 0.007 inch side play.

2.144 Typebar Heels should strike the pallets of other typebars in the space between

the upper and the lower-case characters, gauged by eye, when one bar is held in the typebar guide and each of the others is raised up to it.

To Adjust: Reposition the type pallets as outlined below.

2.145 Alignment of Type: The inking should be uniform over the entire surface of each typed character and from one character to another. No character should be noticeably high or low nor slant with respect to the letter N. All characters should appear centrally spaced.

Note: The N typebar and pallet on each typing unit are aligned at the factory to serve as a master for use in aligning other typebars and pallets.

To Check: Type a series of characters between the letter N as NANBNCN, etc. In case of doubt on any character, type the character at least 6 times between two letter N's. The bottom of the large fractions should line up with the bottom of the letter N.

Note: Before checking the type alignment, verify the LTRS and FIGS stop-screw adjustments in 2.52 and 2.53, and the typebar adjustments in 2.142, 2.143, and 2.144.

If only a few type pallets are out of alignment, readjust them as shown below under "To Adjust

Horizontal Alignment": If many type pallets are out of alignment proceed as follows. First check the position of the N type pallet with the other type pallets. If this test indicates that the N type pallet is satisfactory, leave it alone. If the N type pallet is not satisfactory, reposition it as shown below under "To Adjust Horizontal Alignment": or temporarily replace the N typebar by a master N typebar TP82021, in order to reduce readjustment of the other type pallets. In any case, then align the other type pallets with the pallet of either the regular or master N typebar. Finally, replace the regular N typebar if necessary and align its type pallet with the other characters. If many type pallets require readjustment it may be found advantageous to use the TP116749 type soldering jig.

Note: The following adjustments are inter-related and it is necessary, when making one adjustment, to recheck others.

To Adjust Horizontal Alignment: Heat the pallet with an electric soldering copper until the solder is melted and then move the pallet up or down by tapping. If the type is still slightly out of alignment raise or lower the character by gripping the typebar about one inch below the type pallet with nine prong pliers TP78591 with single prong to the front for raising the type and single prong to the rear for lowering the type, and press until the correct alignment is obtained.

To Adjust Spacing: Bend the typebar toe with three prong pliers, TP78589. To straighten characters, grip the typebar firmly with short nose pliers just below the pallet and bend the end of the typebar with parallel pliers TP78590.

To Adjust Evenness of Typing: Cut the type just back of the light typing portion to throw this part of the pallet forward, using one-side-type cutting pliers, TP78588, to correct light typing at either side and two-side-type cutting pliers, TP78587, to correct light typing at either top or bottom. Recheck 2.144.

Note: While adjustments may be made with standard repairmen's tools, the adjustments can be more readily accomplished using tools referred to. These tools are not usually included in the repairman's tool kit.

To Replace a Typebar: Remove the typebar carriage (see note above 2.01), the ribbon, the two screws and lock washers mounting

the typebar guide to the adapter plate, and the ribbon carrier after disengaging it from the hook on the ribbon-oscillator lever, and then lift the typebar guide off its dowels; raise the typebar in question until it passes the ribbon-oscillator lever, then raise the selected pullbar until it is disengaged from the typebar and remove the typebar from its slot in the typebar segment. Insert the new typebar in the slot just vacated, engaging the teeth on the pullbar so the top of the pullbar is even with the tops of the other pullbars when the typebar is resting against its backstop. New typebars are usually oversize and the section which fits in the segment will probably have to be stoned down with the TP87698 carborundum stone so that the typebar does not bind and has no more than 0.003 inch side play when against its backstop, or 0.002 inch side play when in its typing position. Reassemble the typebar guide on the adapter plate using the two screws and lock washers previously removed, the ribbon carrier on the typebar guide engaging its lower end in the ribbon-oscillator lever hook, and the typebar carriage on the typing units (See Note under 2.40.). Recheck 2.133 and 2.141 to 2.143. If the N type pallet has been replaced, recheck 2.52 and 2.53.

2.146 **Motor Unit** assembled on a teletypewriter base with a typing unit and keyboard unit should meet the following requirements.

- (a) Motor-pinion should be smooth and free from nicks. Install a new pinion if necessary.
- (b) Motor should be so located that the axis of the pinion-shaft lies in the midplane of the mainshaft gear.

To Gauge: Visually check lateral alignment of the gear and the pinion.

To Adjust: Remove the typing unit, loosen the 4 motor mounting screws, replace the typing unit and shift the motor, keeping the edges of the motor base and plate parallel. Many motors are equipped with elongated mounting-holes to give a wider range of adjustment. Remove the typing unit, tighten the motor mounting screws and replace the typing unit.

Note: In replacing the typing unit, care should be taken to prevent damaging the mainshaft gear.

(c) The motor-pinion and the mainshaft gear should not bind and there should be barely perceptible backlash between them when they are at the closest point in their revolution.

Gauge: Bind by feel. Gauge for backlash by eye, holding the mainshaft gear and rocking the motor-shaft back and forth.

To Adjust: Loosen the rear motor-plate mounting screw and the locknut on the motor-plate adjusting screw, start the motor, and carefully readjust the vertical position of the motor-plate adjusting screw until the gear noise is reduced to a

minimum. Tighten the rear motor-plate mounting screw and adjusting-screw locknut, then recheck backlash.

CAUTION: IN MAKING THIS ADJUSTMENT WITH THE MOTOR RUNNING, CARE SHOULD BE TAKEN TO AVOID DAMAGING THE MAINSHAFT GEAR OR REDUCING THE SPEED OF THE MOTOR AS THE RESULT OF TOO CLOSE A MESH BETWEEN THE GEAR AND THE PINION.

Note: For all other motor unit requirements and adjustments, refer to the section covering motor units.

3. LIST OF FUNCTION LEVERS

3.01 The following list is given to show the functions performed by, and the stamping on, the various function levers.

LIST OF FUNCTION LEVERS

<u>Stamping</u> (Note 1)		<u>Code</u> <u>Selection</u>	<u>Function Performed</u>
<u>Old</u>	<u>New</u>		
1	1	All Combinations	Locks vanes
2	2	- - - 4 -	Carriage return
S-2	2-B	- - - 4 -	Carriage return in LTRS position only
3	3	1 2 - 4 5	Shift to FIGS position
4	4	1 - 3 - -	Bell on FIGS S
4	4-A	1 2 - 4 -	Bell on FIGS J
4	4-B	- - - - -	Bell on Blank
U	5-A	Any printed character	Resets send-receive-break mechanism
6	6-A	1 - - - 5	Tabulation on FIGS Z
6	6-B	- 2 - 4 5	Tabulation on FIGS G
No Stamping		Note 2	Closes a contact to control an external circuit
7	7-A	- - - - -	Suppresses printing and spacing on Blank
7	7-B	- - - - -	Suppresses printing and spacing on Blank in LTRS position only
9	9	- - 3 - -	Shift to LTRS position on Space
10	10	- - - - -	Operates send-receive-break mechanism on Blank
11	11	1 2 3 4 5	Shift to LTRS position
12	12	- 2 - - -	Line Feed
S-12	12-A	- 2 - - -	Line Feed in LTRS position only
13	13	- - 3 4 5	Motor stop on FIGS M
13	13-C	- - - - -	Motor stop on FIGS Blank
13	13-D	- - 3 - 5	Motor stop on FIGS H
No Stamping		Note 2	Opens a contact to control an external circuit

Note 1: Stamping indicates position used.

Note 2: Function lever TP116965 may be modified to respond to any desired code selection.