

20 TELETYPEWRITER

WIRING DIAGRAM

1. GENERAL

1.01 This section gives the wiring of the various apparatus units of the 20 teletypewriter.

1.02 This section is reissued to include the wiring diagram for the 20 reperforator. The wiring diagram for the 20 reperforator is the same as that for the 14A reperforator.

1.03 The 20 teletypewriter wiring is the same as the 15 teletypewriter wiring except that the sending contacts have six selecting contacts instead of five. For a typical circuit, see Figure 1 of the section covering the 15 teletype-

writer wiring diagram. For the wiring diagrams of the typing unit, keyboard, and base refer to the sections covering the wiring diagrams for the 15 typing unit, 15 teletypewriter keyboard, and 15 teletypewriter base.

1.04 The 20 transmitter-distributor is the same as the 14 transmitter-distributor except that the distributor has the additional O segment after the No. 5 segment, and the additional O sending contact adjacent to the No. 1 contact and connected by a black wire. For the wiring of the 20 transmitter-distributor, see the section covering the 14 transmitter-distributor wiring diagram.

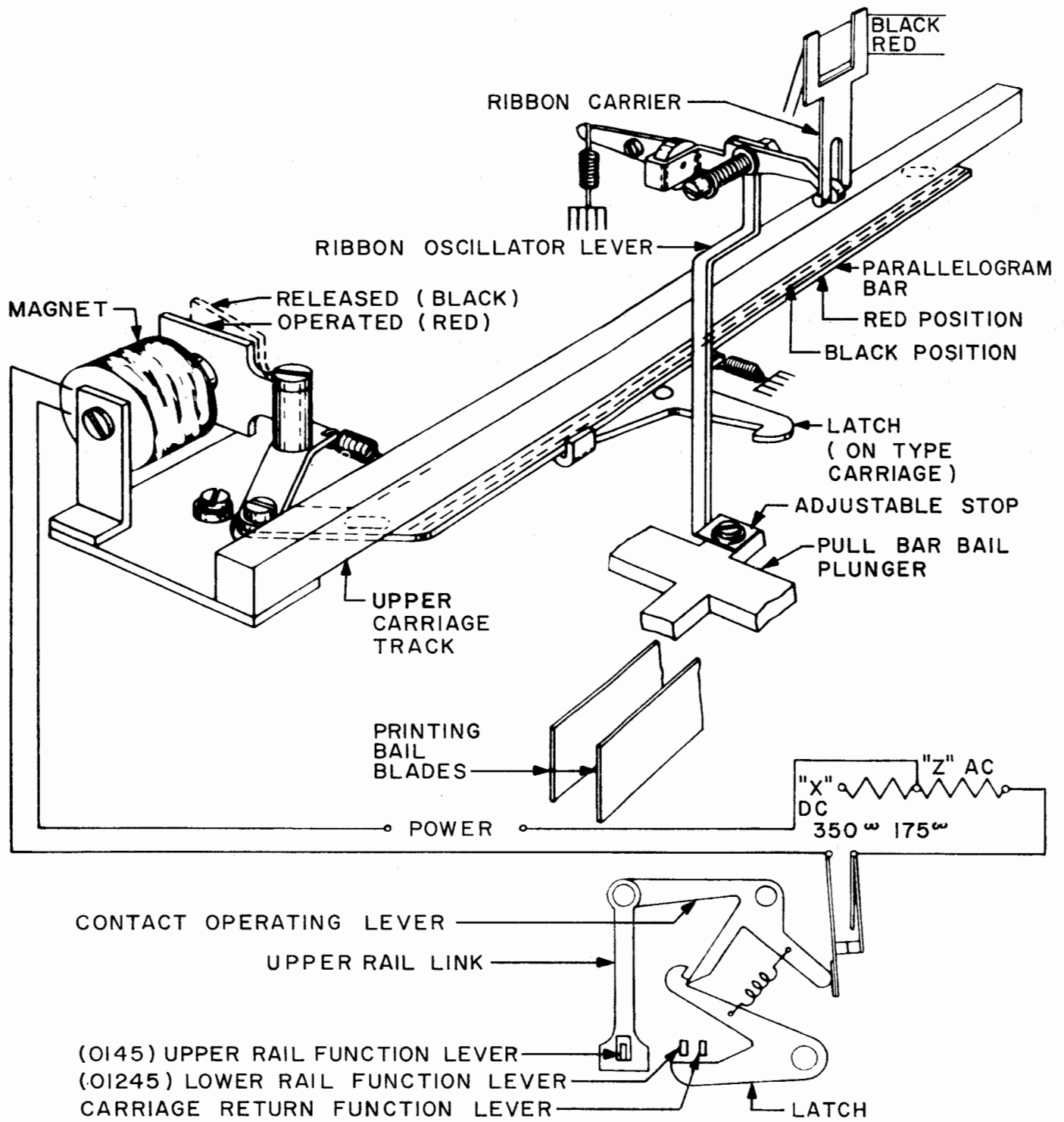

Figure 1-20 Teletypewriter
Two-color Printing Mechanism
Theory Sketch

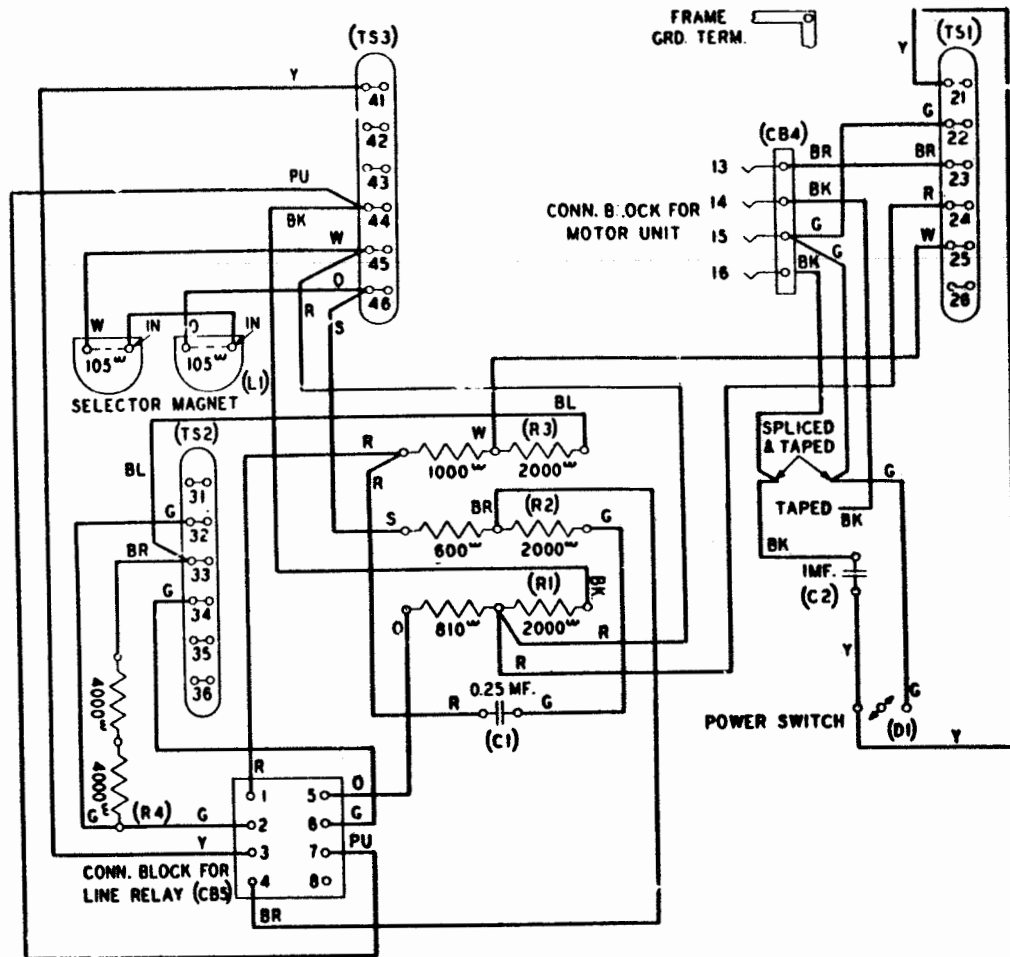

Figure 2 - 20 Reperforator Unit
(14A Reperforator Unit - Later Design)

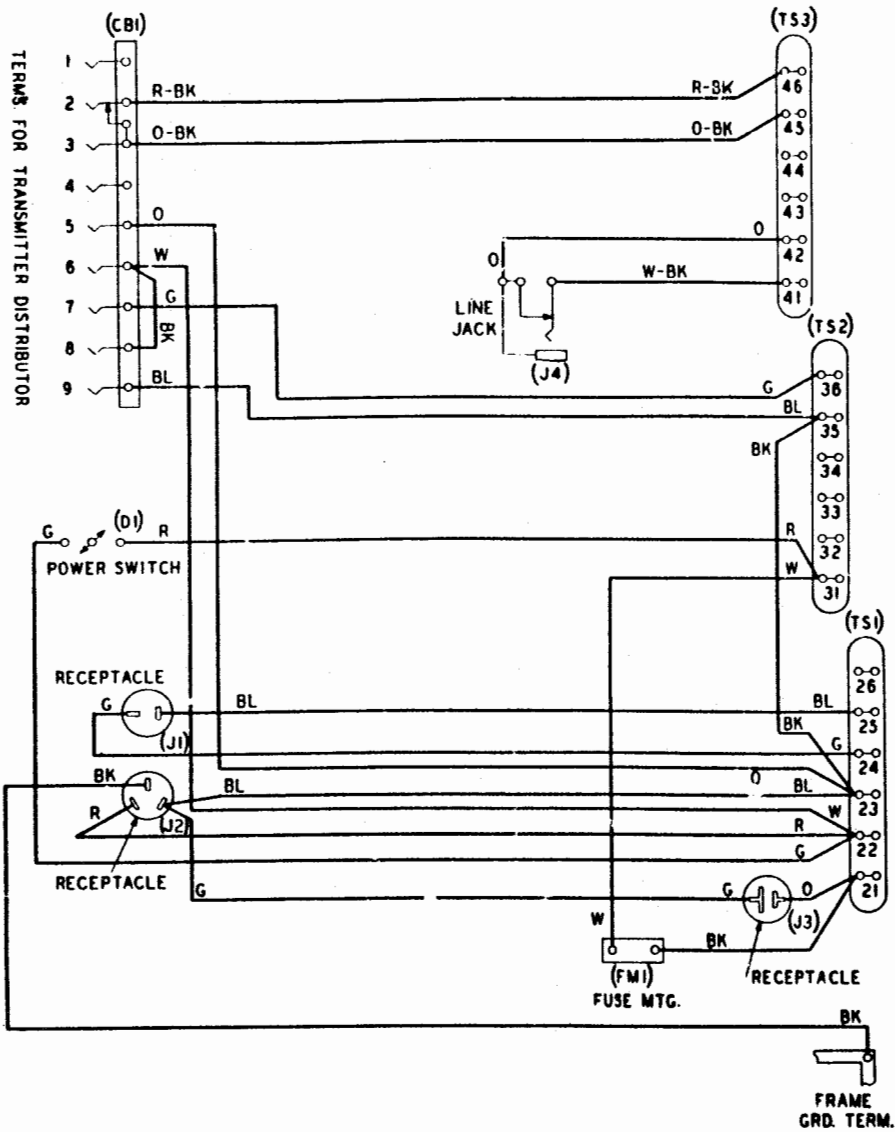

Figure 3 - 20 Reperforator Base
(14A Reperforator Base Plate)

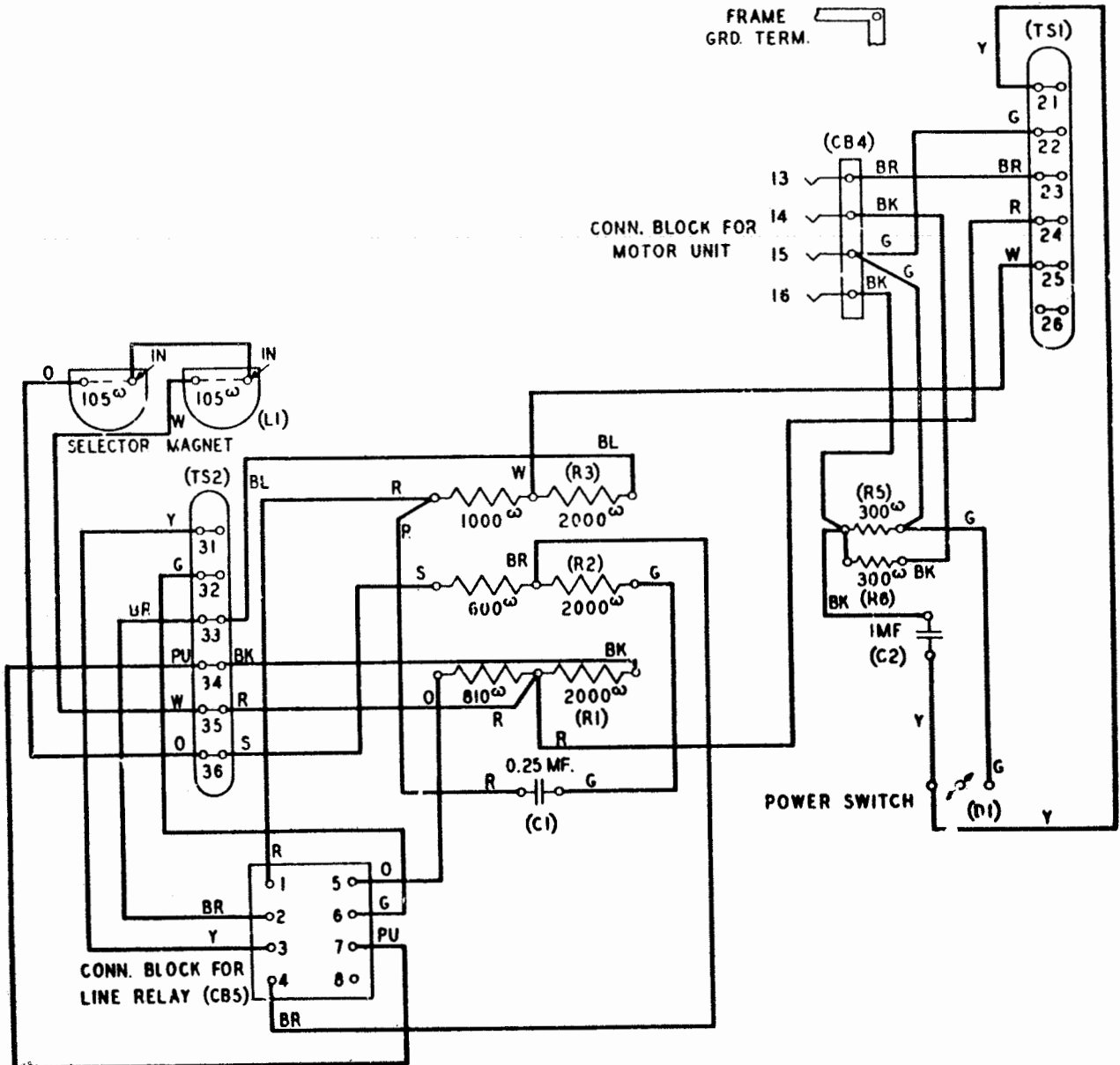

Figure 4 - 20 Reperforator Unit
(14A Reperforator Unit - Earlier Design)