

- NO. NOTES
1. WIRING LEGEND:
DISTANT TERMINATING AREA
DISTANT TERMINATING DESIGNATION
A-2-W-BK
WIRE COLOR CODE
 2. COLOR CODE:
BK - BLACK G - GREEN
BR - BROWN BL - BLUE
R - RED P - PURPLE
O - ORANGE W - WHITE
Y - YELLOW S - SLATE
 3. * DENOTES 18 GA. WIRE
X DENOTES 20 GA. WIRE
X DENOTES 22 GA. WIRE
ALL OTHER WIRE 24 GA.
 4. -Ø- DENOTES SHIELDED WIRE
 5. ALL WIRES WITHOUT COLOR DESIGNATIONS ARE SURFACE WIRING.
 6. ALL WIRING SHOWN FROM SOLDER SIDE.
 7. AREA DESIGNATIONS SHOWN AS VIEWED FROM REAR OF CABINET, EXCEPT CONTROL PLATE.
 8. DESIGNATIONS ENCLOSED IN PARENTHESES ARE FOR REFERENCE AND ARE NOT SHOWN ON COMPONENT.
 9. LINE RELAY CIRCUITS WIRED FOR .050 AMPERE NEUTRAL OPERATION. FOR .020 AMPERE OPERATION, MOVE BLACK STRAP FROM 1 AND 2 TO 3 AND 4. FOR POLAR OPERATION, REMOVE STRAP.
 10. CONNECTOR PLUG
 11. RUBBER STAMP WITH 1/4" LETTERS RELAY TERMINAL BLOCK IDENTIFICATIONS BC, BD, BE, BF, BG AND BH ON UPPER RIGHT CORNER OF 152109 FILTERS. USE BLACK INK. COVER WITH LACQUER.
 12. SL-BL INDICATES SLOW-BLOWING.

176552 CONTROL PLATE ASSEMBLY

A
176552 CONTROL PLATE
THIS PLATE SHOWN FROM TERMINAL
SIDE
(FRONT OF CABINET)

NOTE:
REVISION INFORMATION MUST ALSO BE REFLECTED ON THE ISSUE CONTROL RECORD, WHICH IS A PART OF THIS DRAWING.

4365 WD		
REVISIONS		
ISSUE	DATE	AUTH. NO.
2	6-21-61	70344
3	8-11-61	70592
4	8-16-61	70592-1
5	10-5-61	71172
6	10-30-61	71450
7	11-20-61	71638
8	11-24-61	71760
9	5-22-62	73480
10	6-25-62	73871
11	8-3-63	77453
12	6-22-64	82397
13	2-2-65	89157
14	11-23-65	92192
15	10-18-74	12472-R C

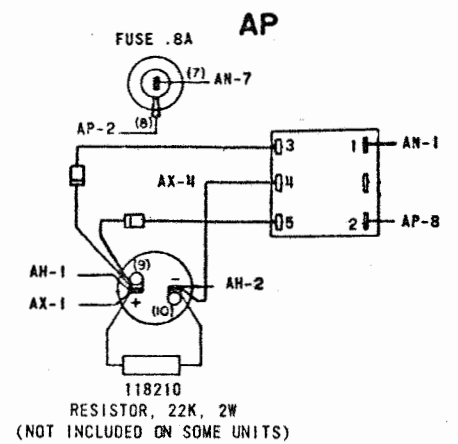
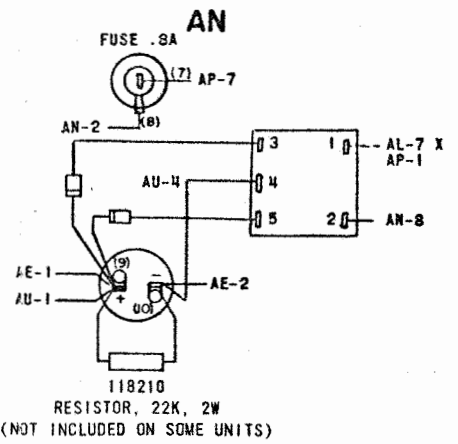
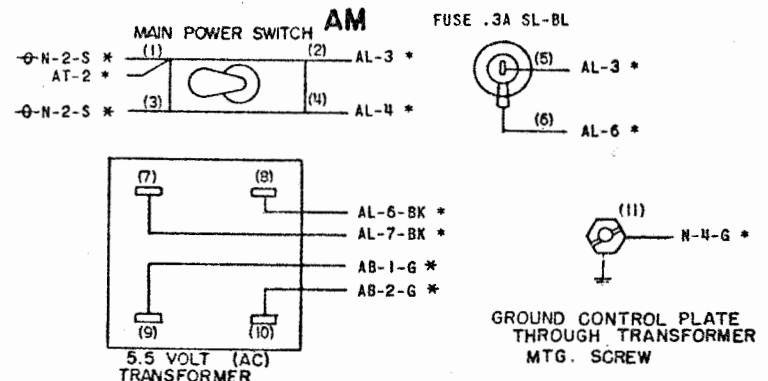
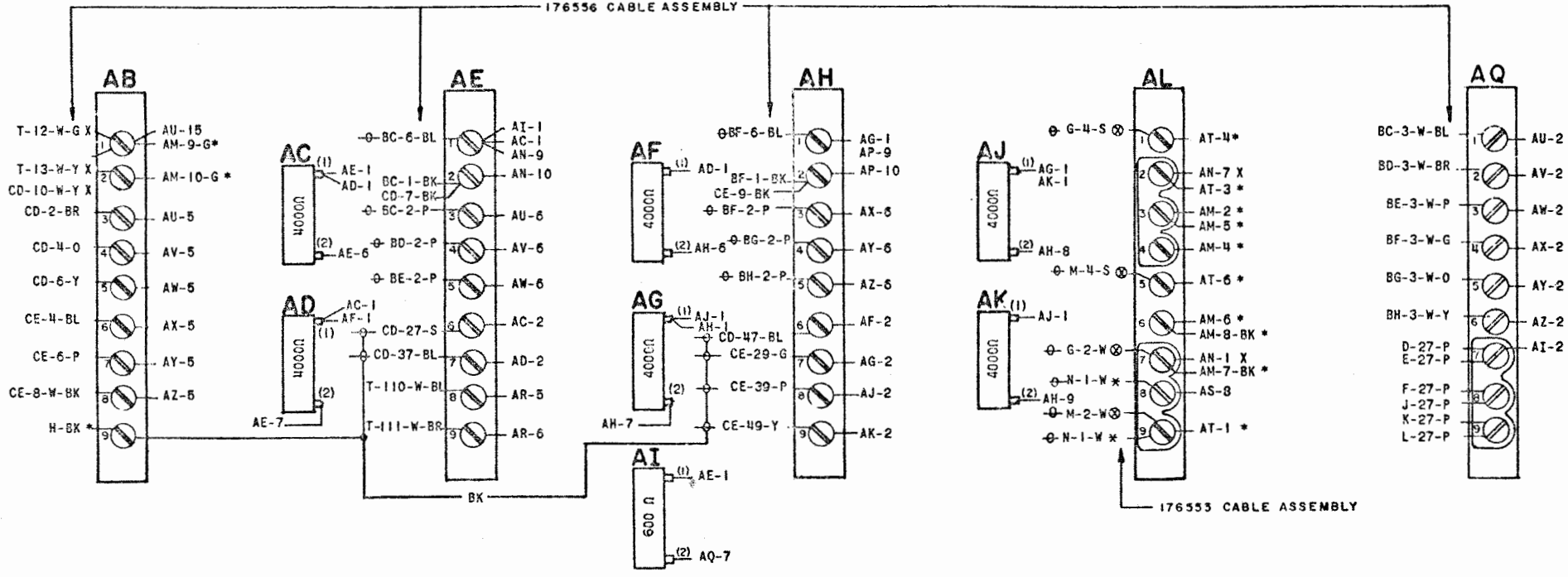

SEE ISSUE CONTROL RECORD FOR COMPLETE LIST OF SHEETS COMPRISING THIS W.D.

SHEET 1
ACTUAL WIRING DIAGRAM FOR RECEIVING-TYPING REPERFORATOR CABINET LBAC231

APPROVALS
D AND R E OF M

E-NUMBER
PROD. NO. 4365WD
DATE 3-20-61
P.D. FILE NO. 40-A2/65AA
DRAWN C.E.L. CHKD.
ENGD. R.L.F. APPD.

TELETYPE CORPORATION
4365 WD

SEE SHEET 1 FOR NOTES.

176552 CONTROL PLATE ASSEMBLY

NOTE:
REVISION INFORMATION MUST ALSO BE
REFLECTED ON THE ISSUE CONTROL REC-
ORD, WHICH IS A PART OF THIS DRAWING.

4365WD

REVISIONS

ISSUE	DATE	AUTH.
2	2-2-66	89157

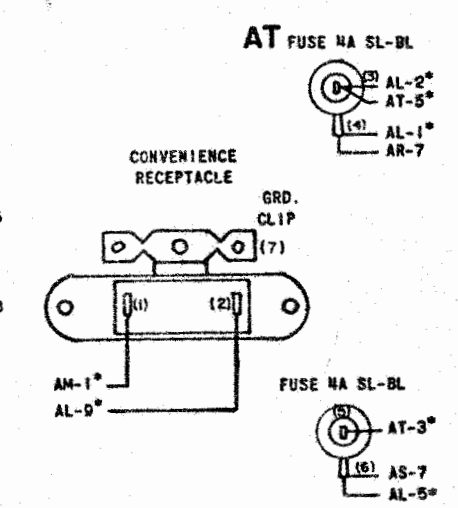
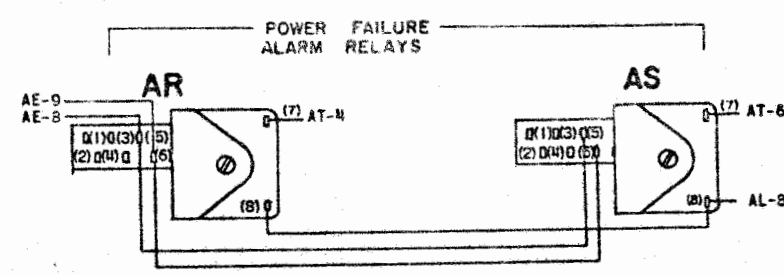
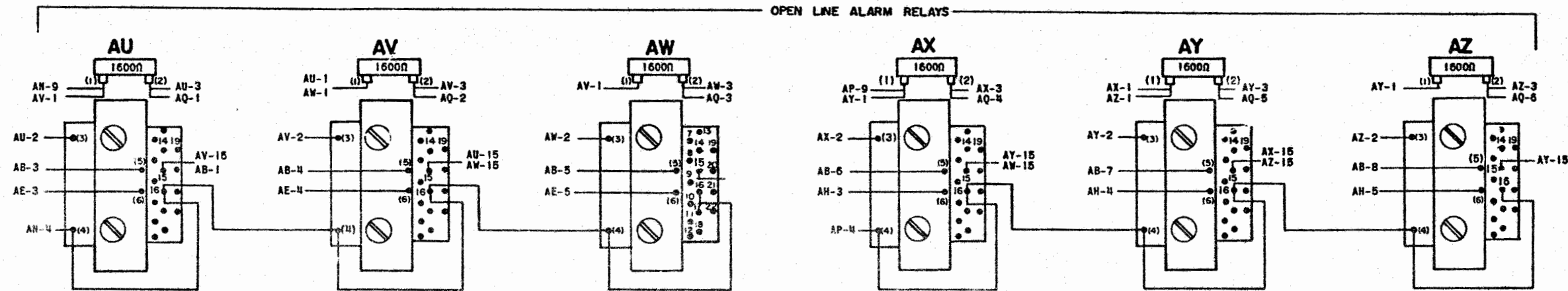

SEE ISSUE CONTROL RECORD FOR COMPLETE LIST OF SHEETS COMPRISING THIS W.D.

SHEET 2

ACTUAL
WIRING DIAGRAM
FOR
MODEL 28
RECEIVING-TYPING
REPERFORATOR CABINET
LBAC231

APPROVALS

D AND R	E OF M
---	---

E-NUMBER
PROD. NO. 4365WD
DATE 3-20-61
P.D. FILE NO. NO-A2/65AA
DRAWN C.E.L. CHKD.
ENGD. R.L.F. APPD.

TELETYPE CORPORATION

4365WD

SEE SHEET 1 FOR NOTES.

178610 LINE RELAY MOUNTING ASSEMBLY

NOTE:
REVISION INFORMATION MUST ALSO BE
REFLECTED ON THE ISSUE CONTROL REC-
ORD, WHICH IS A PART OF THIS DRAWING.

4365WD

REVISIONS

ISSUE	DATE	AUTH. NO.
2	10-6-66	91060
3	6-17-71	3750

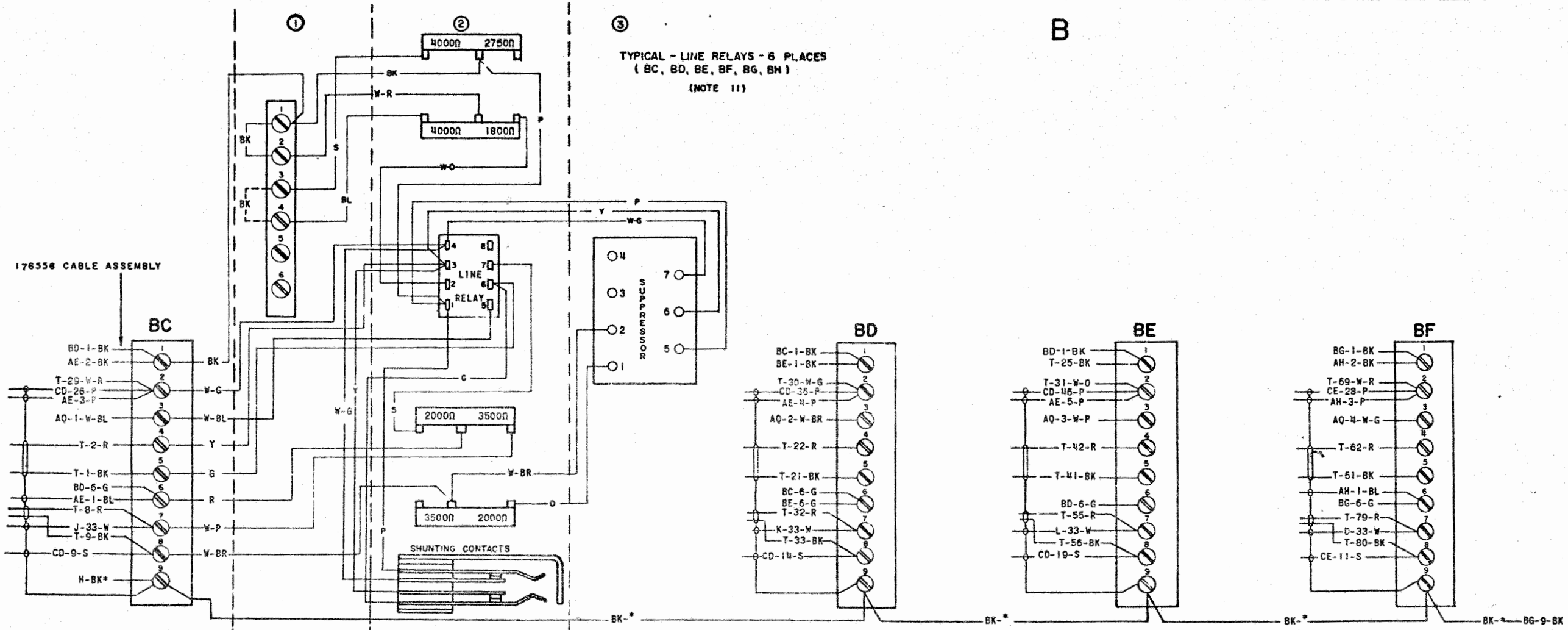

TYPICAL - LINE RELAYS - 6 PLACES
(BC, BD, BE, BF, BG, BH)
(NOTE 11)

176556 CABLE ASSEMBLY

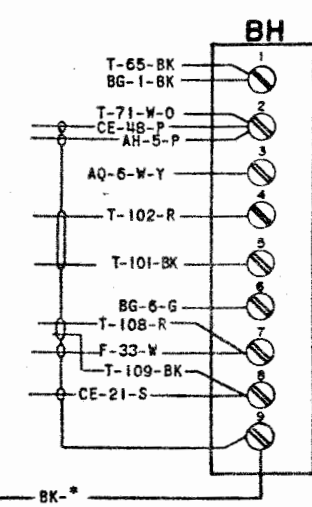
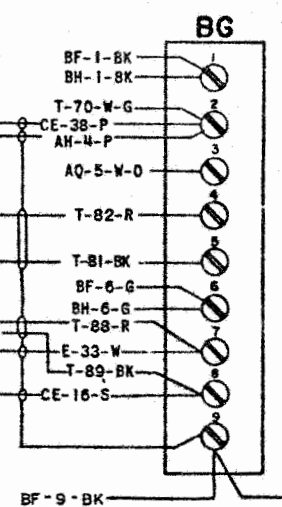
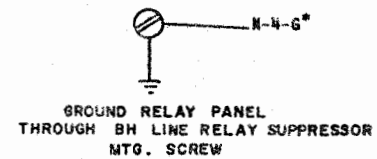
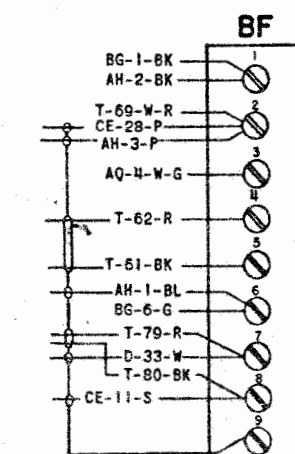
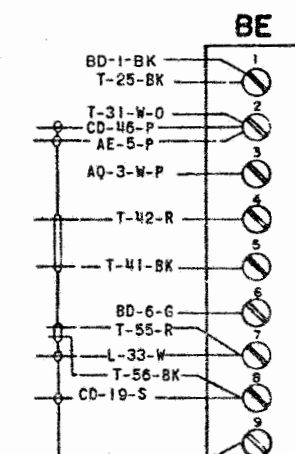
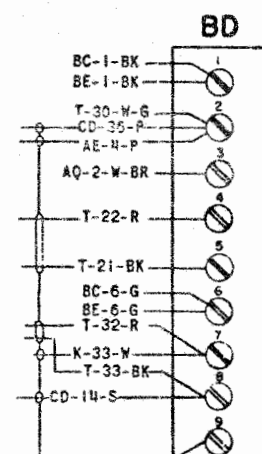
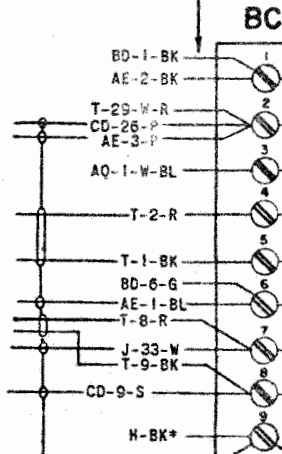

1	BC-5	BK	25	BE-1	BK	49	CD-11	S	73			97	
2	BC-4	R	26	K-23	Y	50	CD-16	W-O	74			98	
3			27	K-24	S	51	CD-21	G	75			99	
4			28			52	CE-13	W-BL	76			100	
5			29	BC-2	W-R	53	CE-18	W-P	77			101	BH-5 BK
6	J-23	Y	30	BD-2	W-G	54	CE-23	W-S	78			102	BH-4 R
7	J-24	S	31	BE-2	W-O	55	BE-7	R	79	BF-7	R	103	
8	BC-7	R	32	BD-7	R	56	BE-8	BK	80	BF-8	BK	104	
9	BC-8	BK	33	BD-8	BK	57			81	BG-5	BK	105	
10	STRAP TO		34			58			82	BG-4	R	106	F-23 Y
11	STRAP TO		35			59			83			107	F-24 3
12	AB-1	X	36			60			84			108	BH-7 R
13	AB-2	X	37			61	BF-5	BK	85			109	BH-8 BK
14	STRAP TO		38			62	BF-4	R	86	E-23	Y	110	AE-8 W-BL
15	STRAP TO		39			63			87	E-24	S	111	AE-9 W-BR
16			40			64			88	BG-7	R	112	
17			41	BE-5	BK	65	BH-1	BK	89	BG-8	BK	113	
18	CE-1	P	42	BE-4	R	66	D-23	Y	90			114	
19			43			67	D-24	S	91			115	
20			44			68			92			116	
21	BD-5	BK	45			69	BF-2	W-R	93			117	
22	BD-4	R	46	L-23	Y	70	BG-2	W-G	94			118	
23			47	L-24	S	71	BH-2	W-O	95			119	
24			48			72			96			120	

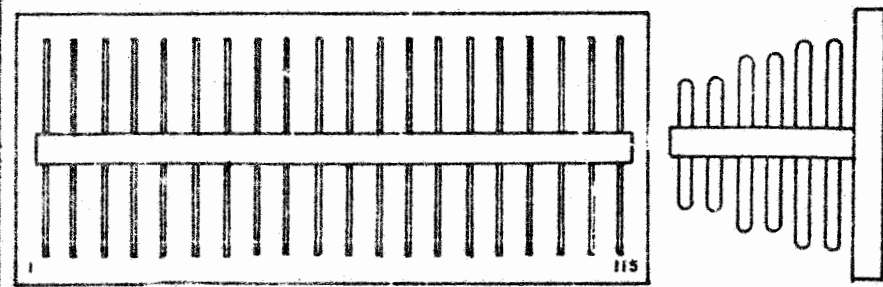

SEE ISSUE CONTROL RECORD FOR COMPLETE LIST OF SHEETS COMPRISING THIS W.D.
SHEET 3

ACTUAL WIRING DIAGRAM FOR MODEL 28 RECEIVING-TYPING REPERFORATOR CABINET LBAC231

APPROVALS
D AND R E OF M

E-NUMBER
PROD. NO. 4365WD
DATE 3-20-61
P.D. FILE NO. 40-A2/65AA
DRAWN C.E.L. CHKD.
ENGD. R.L.F. APPD.

TELETYPE CORPORATION
4365WD

SEE SHEET 1 FOR NOTES.

176530 CONTROL PANEL ASSEMBLY

CD

REPERFORATOR LOCAL & REMOTE SEIZURE LAMPS AND OPEN LINE LAMPS.

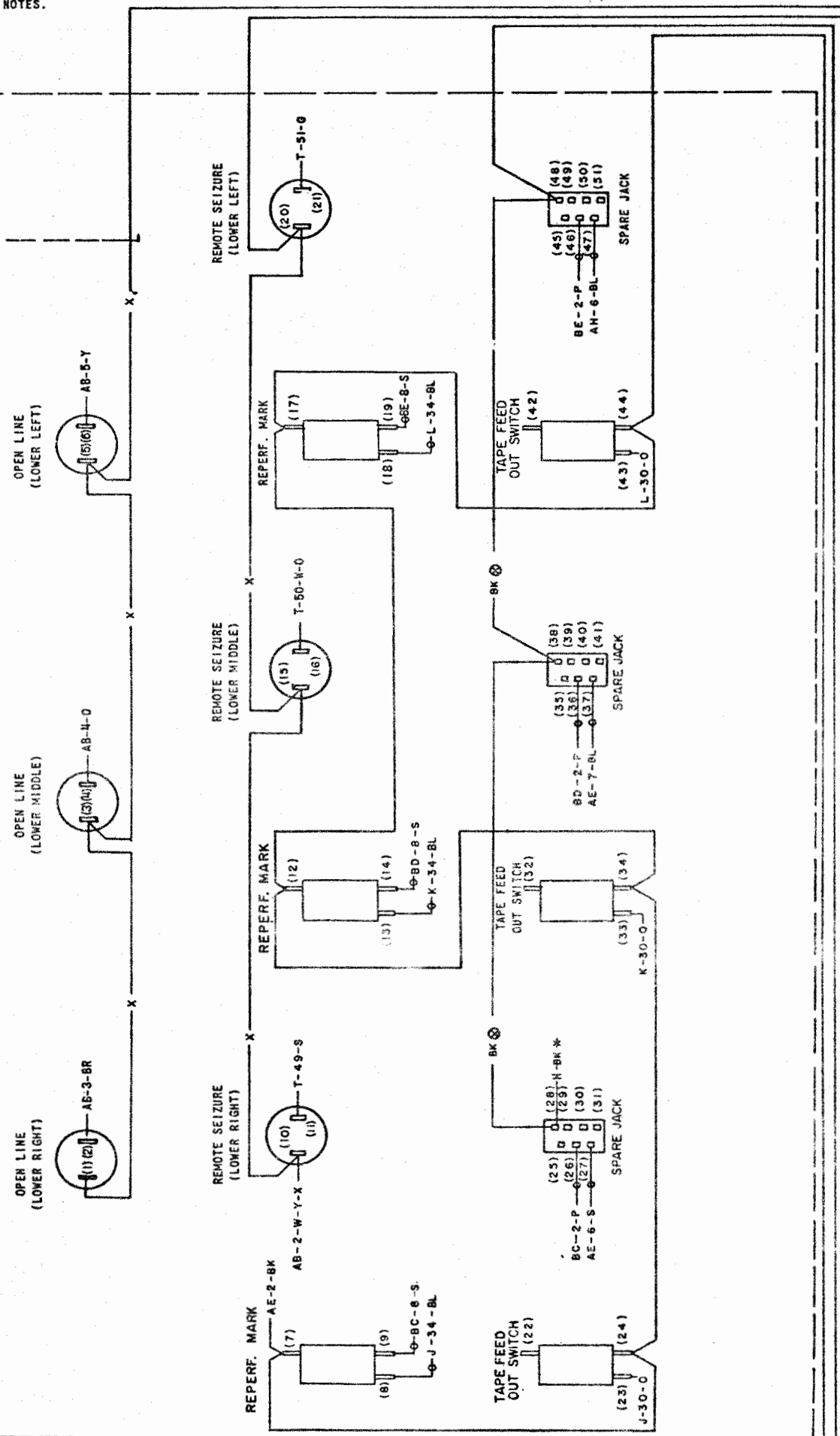

CE

REPERFORATOR LOCAL & REMOTE SEIZURE LAMPS AND OPEN LINE LAMPS.

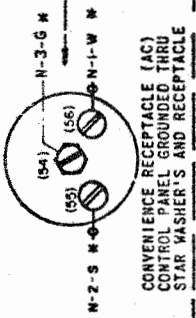
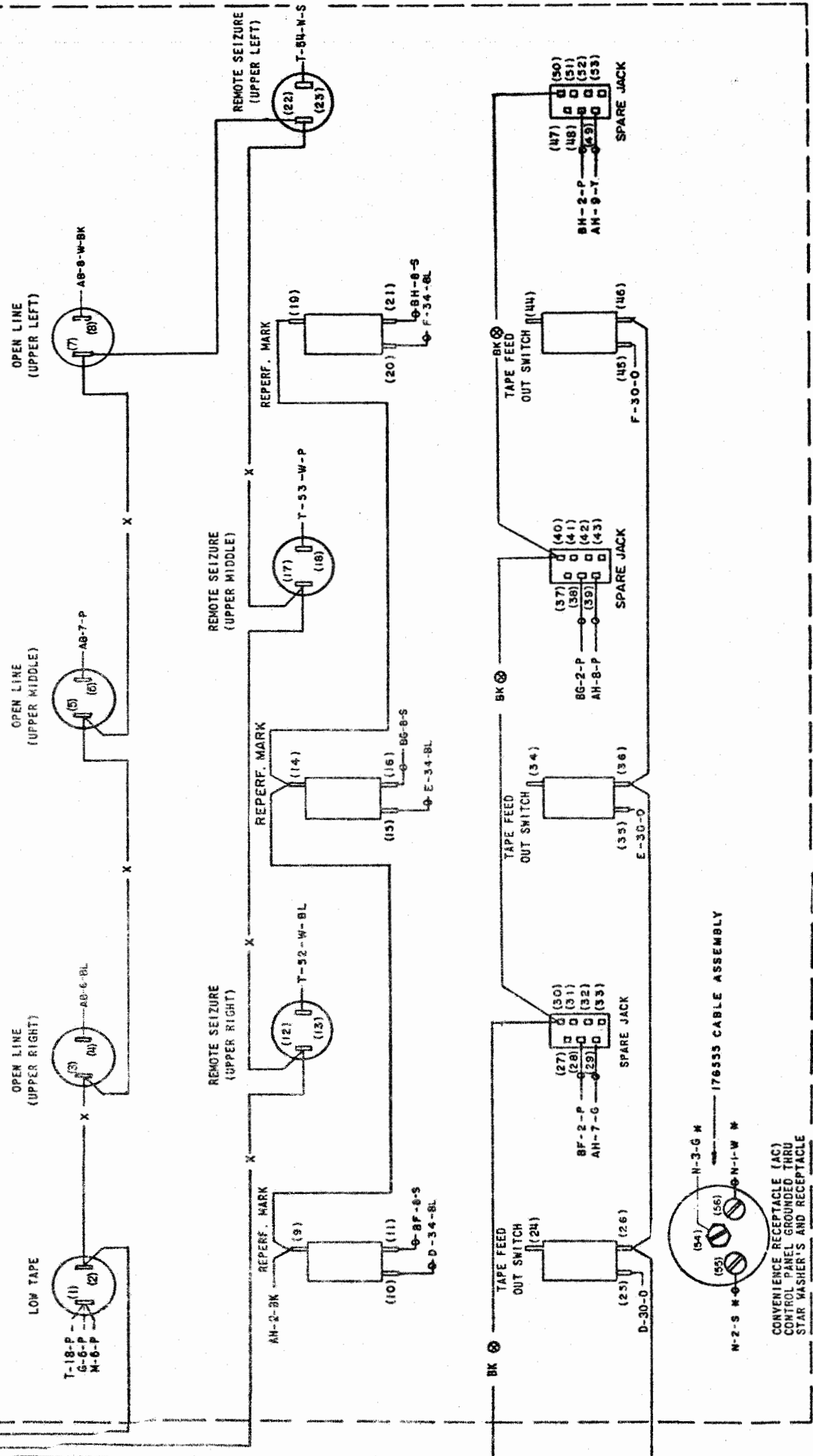

4365WD

REVISIONS		
ISSUE	DATE	AUTH. NO.

NOTE: REVISION INFORMATION MUST ALSO BE REFLECTED ON THE ISSUE CONTROL RECORD, WHICH IS A PART OF THIS DRAWING.

SEE ISSUE CONTROL RECORD FOR COMPLETE LIST OF SHEETS COMPRISING THIS W.D.

SHEET 11

ACTUAL WIRING DIAGRAM FOR MODEL 28 RECEIVING-TYPING REPERFORATOR CABINET LBAC231

APPROVALS

D AND R	E OF M

E-NUMBER

PROD. NO. 4365WD

DATE 3-20-61

P.D. FILE NO. 40-A2/65AA

DRAWN C.E.L. CHKD.

ENGD. R.L.F. APPD.

TELETYPE CORPORATION

4365WD

SEE SHEET 1 FOR NOTES.

NOTE:
REVISION INFORMATION MUST ALSO BE
REFLECTED ON THE ISSUE CONTROL REC-
ORD, WHICH IS A PART OF THIS DRAWING.

4365WD

REVISIONS

ISSUE	DATE	AUTH. NO.

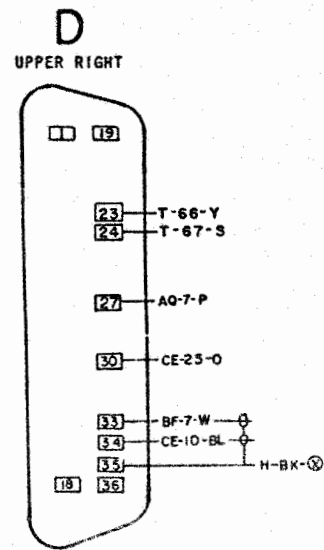

NOTE 10

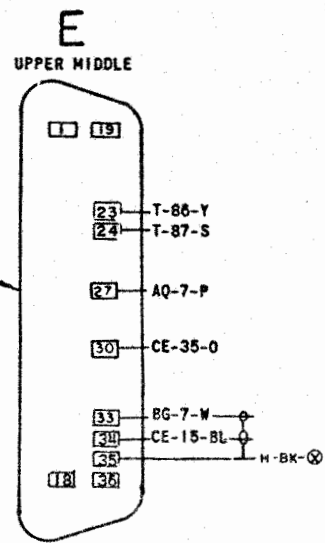

NOTE 10

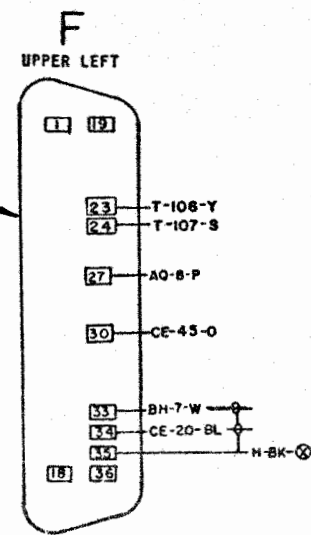

G
UPPER BASE

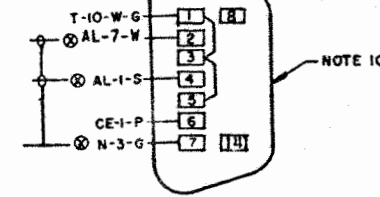

NOTE 10

H
SHIELD GRD.
TERMINAL STRIP

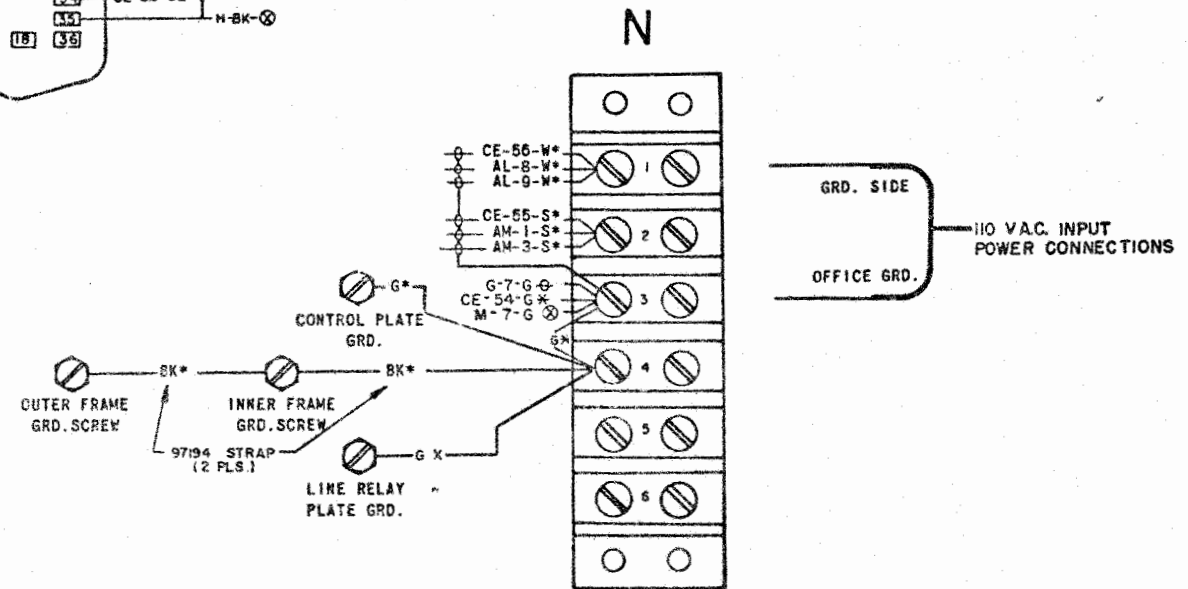
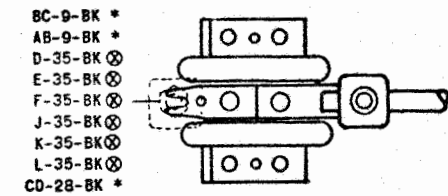

GRD. SIDE
OFFICE GRD.
110 VAC. INPUT
POWER CONNECTIONS

SEE ISSUE CONTROL RECORD FOR COMPLETE LIST OF SHEETS COMPRISING THIS W.D.

SHEET 5

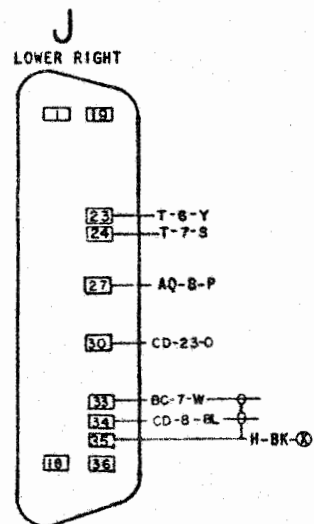

NOTE 10

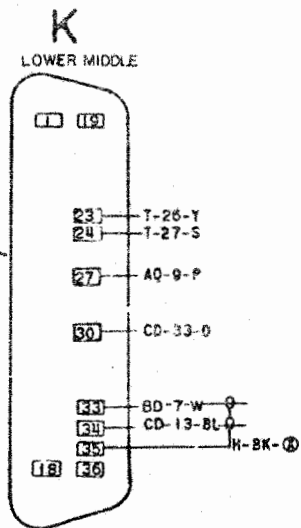

NOTE 10

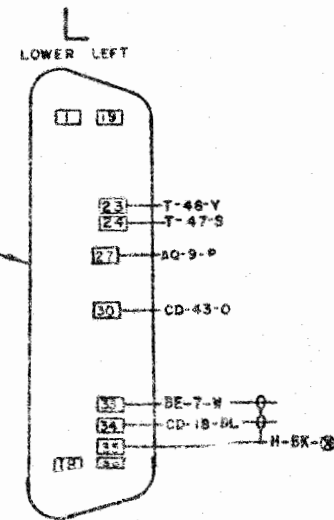

M

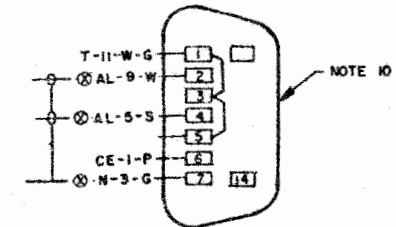

NOTE 10

ACTUAL
WIRING DIAGRAM
FOR
MODEL 28
RECEIVING-TYPING
REPERFORATOR CABINET
LBAC231

APPROVALS

D AND R	E OF M

E-NUMBER
PROD. NO. 4365WD
DATE 3-20-61
P.D. FILE NO. 40-A2/65AA
DRAWN C.E.L. CHKD.
ENGD. R.L.F. APPD.

TELETYPE
CORPORATION

4365WD