

506-1820-002 R-391

506-1820-002-R-391

NOTE: When Government drawings, specifications, or other data are used for any purpose other than in connection with a definitely related Government procurement operation, the United States Government hereby incurs no responsibility or obligation whatsoever, and the fact that the Government may have furnished, furnished, or in any way supplied this said drawings, specifications, or other data is not to be regarded by implication or otherwise as in any manner binding the holder or any other person or organization, or conveying any rights or privileges by manufacture, use or sale of any patented invention that may in any way be related thereto.

NOTE: FOR INFORMATION ONLY. CONTRACTOR MAY AT HIS OPTION DEVIATE FROM THESE PROCESS DETAILS

APPROVAL	SYMBOL	DATE	DESCRIPTION	DATE	APPROVAL
SM-B-178935	SC-DL-176467				
SM-B-178935	SC-DL-248775				
A ₂		8 OCT. 59	A ₁ - RENUMBERED NOTES; A ₂ - ADDED APPL. SM-B-178935, SC-DL-248775.		REV'D. PME
B ₁		28 FEB. 60	B ₁ - WAS QQ-B-626.		REV'D. PME
C ₁		15 SEP. 60	(1) - ADDED NOTE #5.		REV'D. PME

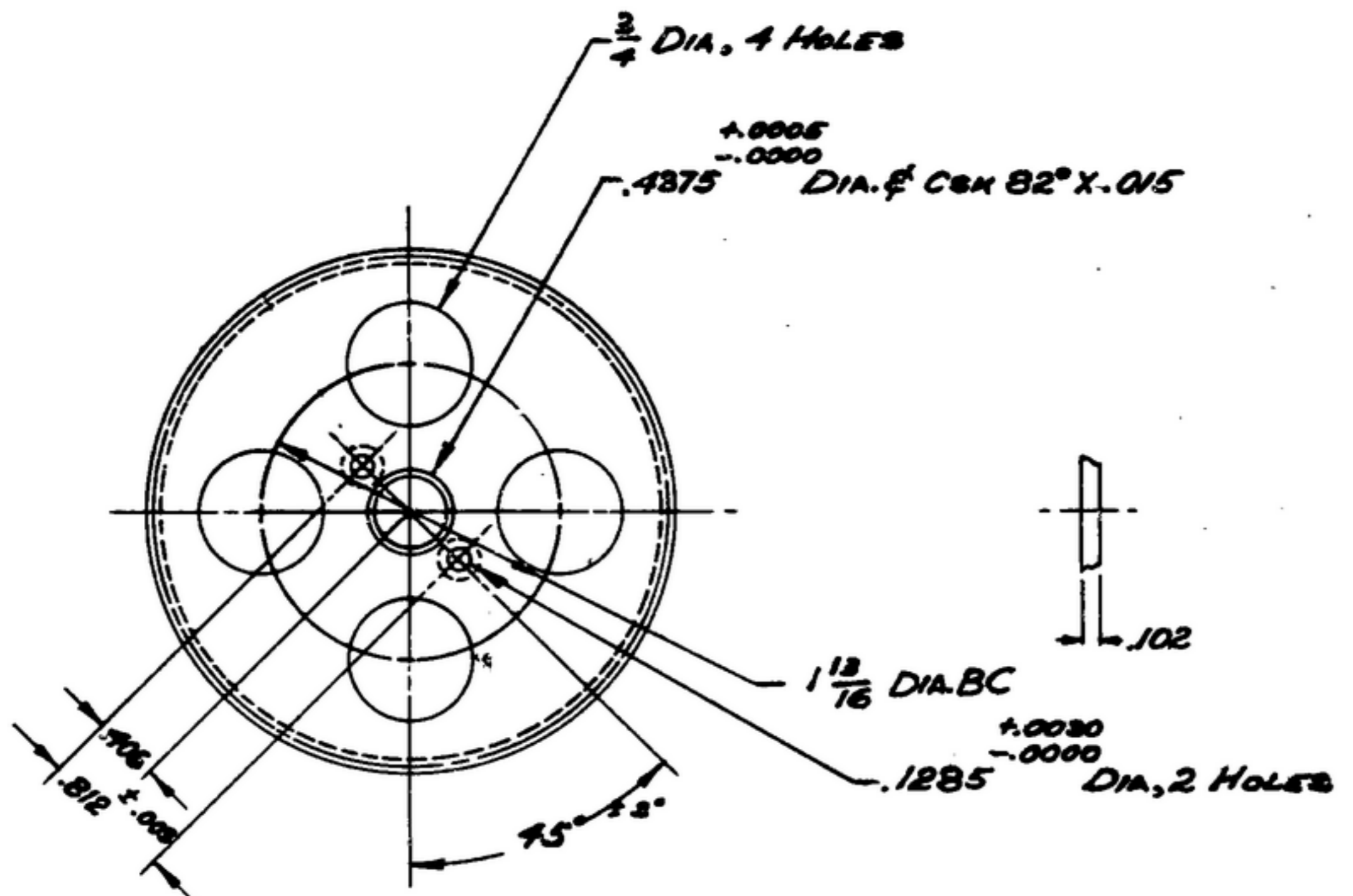

- NOTES: (A₁) (B₁) (C₁)
- BRASS COMPOSITION 1, 1/2 HARD, PER SPEC QQ-B-613
 - NORMAL DIAMETRAL PITCH: 32
 THEORETICAL FITCH DIAMETER 3.125
 NUMBER OF TEETH 100
 PRESSURE ANGLE 20°
 BACKLASH ON NORMAL PITCH CIRCLE WHEN MATED WITH MASTER.001-.002.
 AMERICAN STANDARD INVOLUTE TOOTH FORM.
 - ECCENTRICITY BETWEEN PITCH DIAMETER AND BORE MUST NOT EXCEED .002 TIR.
 - REMOVE ALL BURRS & SHARP EDGES.
 - FINISH: CHEMICAL POLISH PER IRIDITE #7 METCOTE PROCESS BU ALLIED RESEARCH PRODUCTS INC., BALTIMORE, MD., OR EQUAL.

UNLESS OTHERWISE SPECIFIED	AUTHENTICATION	ISSUE	DATE	NOTE
DIMENSIONS ARE IN INCHES	DRAWN 2182-PH-50-93			
TOLERANCES ON FRACTIONS ± 1/64	TRACED PHOTO			
DECIMALS ± .005	CHECKED [Signature]			
ANGLES ±	VERIFIED P.D.B.R.			
COMMERCIAL TOLERANCES APPLY TO STOCK SIZES	APPROVED P.D.B.R.			
ALL SURFACES	REVIEWED PME			
	DATE 22 JUNE 58	SCALE 1/1	90-585	

GEAR

DEPARTMENT OF THE ARMY
SIGNAL CORPS ENGINEERING LABORATORIES
FORT MONMOUTH NEW JERSEY

SM-C-178937

WHEN REFERRING TO THIS DRAWING STATE DRAWING NO., APPLICABLE ISSUE SYMBOL AND DATE