

# HAL M-BEITY KEYBOARD

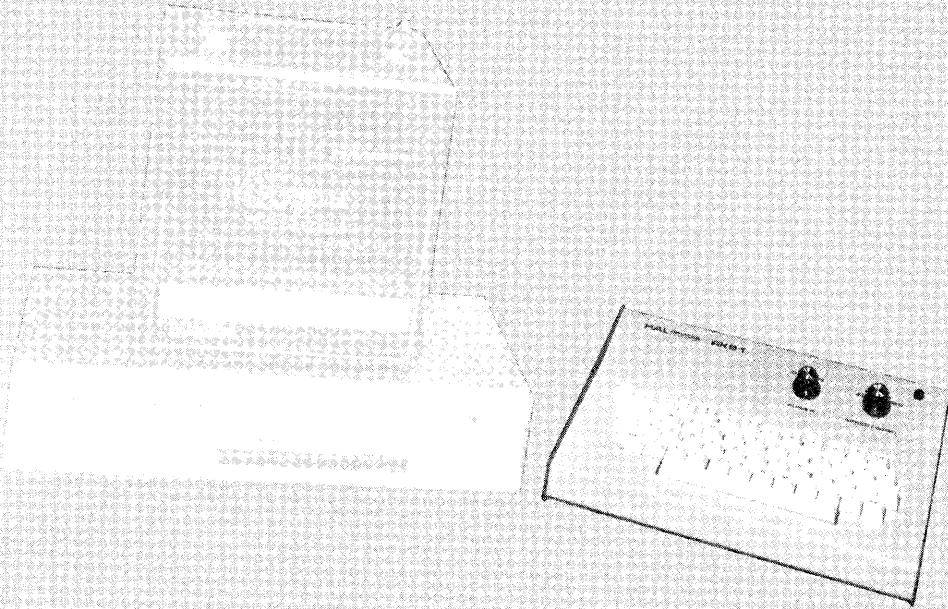

# INSTRUCTION MANUAL

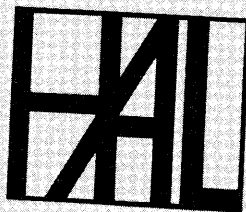

**HAL COMMUNICATIONS CORP.**  
**BOX 365**  
**URBANA, ILLINOIS**      **61801**

**QUALITY COMMUNICATIONS EQUIPMENT**

\*\*\*\*\*

## WARRANTY

HAL Communications Corp. warrants that all RKB-1 TTY Keyboards shall be free of defects in materials and workmanship under normal use and service for a period of one year from the date of the original purchase invoice.

Should such defects occur within the warranty period, notify HAL Communications Corp. promptly in writing. The notification letter must be postmarked prior to one year from the date of the original invoice. Please do not return your unit to the factory for repair until you have sent a letter of notification and have received a written return authorization.

Keyboards returned to the factory under warranty will be repaired or replaced at no charge except for transportation costs.

This warranty is and shall be in lieu of all other warranties, whether expressed or implied, and of all other obligations or liabilities on the part of HAL Communications Corp. resulting from the installation or use of this keyboard.

The foregoing warranty is completely void on all keyboards which have been damaged, abused, modified, or improperly installed or operated.

\*\*\*\*\*

Copyright © 1973 by HAL Communications Corp., Urbana, Illinois. Printed in the United States of America. All rights reserved. Contents of this publication may not be reproduced in any form without the written permission of the copyright owner.

## CONTENTS

1. Introduction . . . . .	1
2. Installation . . . . .	2
3. Operating Instructions . . . . .	4
4. Circuit Description . . . . .	5
5. Maintenance . . . . .	17
6. Diagrams and Photographs . . . . .	21
7. Parts List . . . . .	28

## ILLUSTRATIONS

Figure 2.1: Typical Loop Circuit Connection . . . . .	3
Figure 2.2: Bridge Polarity Protection Circuit . . . . .	3
Figure 4.1: RKB-1 TTY Keyboard Block Diagram . . . . .	6
Figure 4.2: Case Character Decoder Waveforms . . . . .	15
Figure 6.1: RKB-1 Schematic . . . . .	22
Figure 6.2: RKB-1 Logic Board Layout . . . . .	23
Figure 6.3: Photograph of Logic Board . . . . .	24
Figure 6.4: Photograph of Keyswitch Board . . . . .	25
Figure 6.5: Photograph of Interior of RKB-1 . . . . .	26
Figure 6.6: Photograph of Completed RKB-1 . . . . .	27

## TABLES

Table 1: RKB-1 Baudot Code Timing Data . . . . .	5
Table 2: Baudot Code . . . . .	7
Table 3: Master Oscillator Frequencies . . . . .	10

## 1. INTRODUCTION

The HAL RKB-1 is a completely self-contained teleprinter keyboard. Through its advanced integrated circuitry, it produces five-level Baudot code without mechanical coding cams or keying contacts. The RKB-1 can be used with conventional mechanical teleprinter equipment, or may be combined with the HAL RVD-1002 Visual Display System and the HAL ST-6 Terminal Unit to form an all-electronic, silent, and highly reliable RTTY terminal facility.

The RKB-1 offers improved operating convenience and flexibility by incorporating these advanced features:

- Switch selection of four operating speeds: 60, 66, 75 and 100 WPM.
- Complete isolation of the loop switch to permit connection at any point in the loop circuit.
- Automatic transmission of the proper case shift code when transferring from letters to numbers and vice versa.

The RKB-1 is ruggedly constructed to ensure years of trouble-free performance. The logic circuitry and power supply are assembled on a glass-epoxy printed circuit board. The keyswitches, ganged in groups of four and five to ensure accurate alignment, are mounted with the toroidal key encoder on a separate glass-epoxy circuit board. The complete unit is housed in an attractive sloping panel cabinet finished in two-tone gray.

## 2. INSTALLATION

Your RKB-1 keyboard was constructed, tested, packed, and shipped with great care to ensure that you receive it in perfect condition. When you unpack it, inspect it thoroughly and notify the carrier if there is evidence of shipping damage.

### Loop Connections

Since the RKB-1 internal loop switching transistor is completely isolated, the keyboard may be connected at any convenient point in your station's loop circuit. The keying transistor is capable of switching loop currents up to 150 mA and is rated to withstand loop voltages up to 250 volts. Loop connections are made via the loop jack on the rear panel of the keyboard.

**CAUTION:** For safety, switch the station loop supply off during the following operations. Leave it off until the phone plug has been inserted in the keyboard loop jack.

Break the loop circuit at any point desired and connect the positive lead to the tip contact of a two-circuit phone plug. Connect the negative lead to the ring contact. The cable shield, if one is used, may be connected to the plug sleeve contact.

Double check the polarity of the loop leads before inserting the plug in the keyer jack. If the loop is accidentally connected in reverse, the RKB-1 will not be damaged but will be locked in mark condition and it will be impossible to transmit with it. A typical loop circuit configuration is shown in Figure 2.1.

If one lead of the loop circuit to be keyed is grounded, a single-circuit phone plug may be used. Connect the positive lead to the tip contact and the grounded lead to the plug sleeve.

The keyboard output may be made insensitive to the polarity of the loop connections by employing the diode bridge circuit shown in Figure 2.2. The diodes may be positioned at the phone plug terminals so that they are enclosed when the plug cover is installed. The polarity of the diodes must be observed carefully when the circuit is constructed. Once the diodes are installed, however, it is not necessary to determine the polarity of the loop leads when connecting them to the bridge terminals, as the bridge ensures that the voltage applied to the switching transistor is of the proper polarity. This circuit is not recommended for loops operating at less than 30 volts, as the diodes may introduce too much voltage drop. The circuit may be used even if one lead of the loop circuit is grounded, but a two-circuit phone plug must be used to connect the bridge to the keyboard.

After you have completed connections to the phone plug, insert it in the loop jack. Connect the keyboard AC line cord to a 115-volt, 60-Hz outlet, preferably of the three-wire grounding type. The keyboard is now ready to operate.

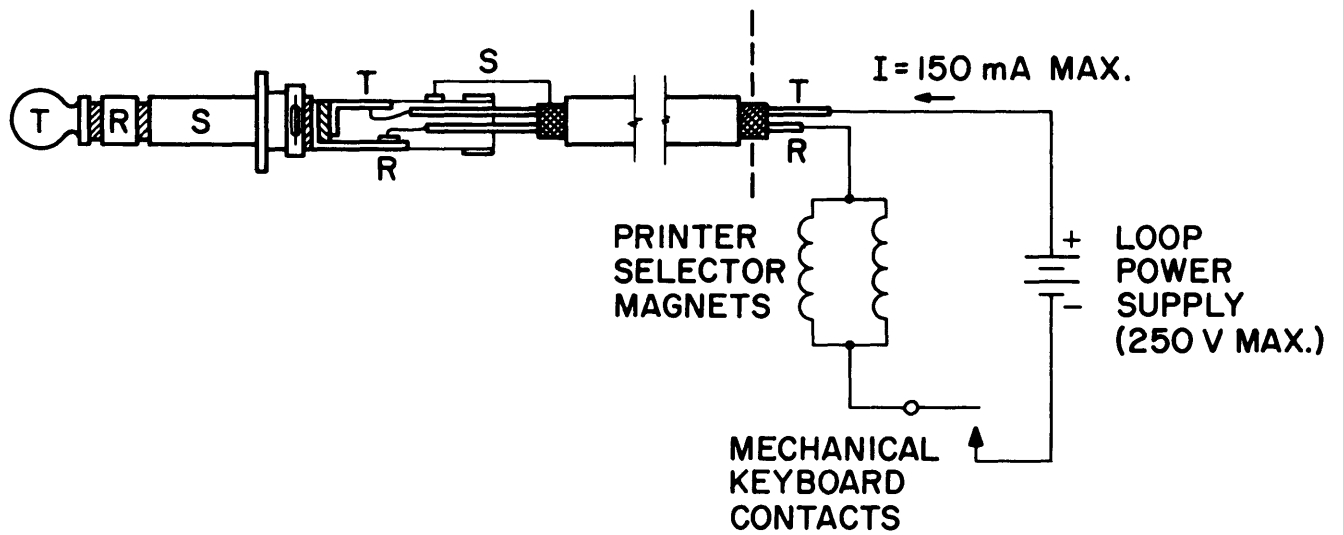

Figure 2.1 Typical Loop Circuit Connection

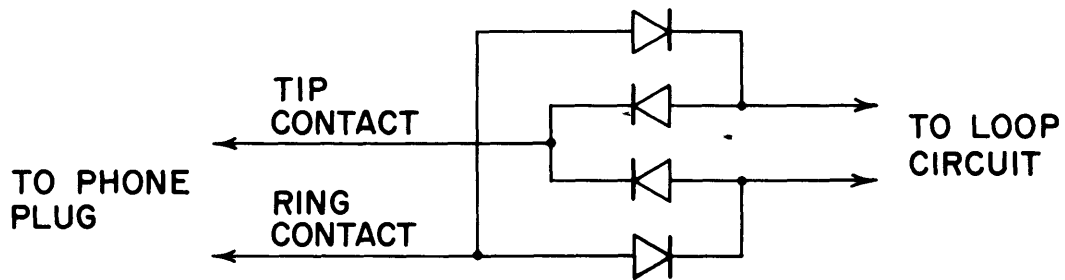

Figure 2.2 Bridge Polarity Protection Circuit

### 3. OPERATING INSTRUCTIONS

You will find that your RKB-1 is simpler and more convenient to operate than a conventional keyboard. First, set the power switch to ON. Then select one of the four operating speeds with the SPEED (WPM) control at the upper right corner of the front panel.

The automatic case shift feature makes it unnecessary to send a figures-shift command before typing numbers. The keyboard generates the shift character automatically before it transmits the number so that the receiving teleprinter will be set to the correct case. Likewise, when you go back to typing letters, the letters-shift character will be generated before the first letter is transmitted. If you type fast--near the maximum rate for the speed you have selected--pause momentarily after typing a character which will cause an automatic case shift. A little extra time will be needed for the keyboard to transmit the shift character.

A manual shift key is also included for accessing punctuation marks and other figures-case characters. Depress the shift key before pushing the character key and hold it down until you have released the character key, just as you would on a regular typewriter.

Like modern mechanical keyboards, the RKB-1 includes a repeat key. To make any character repeat, depress the repeat key, followed by the character key. The character will be transmitted as long as both keys are held down. Release the character key before releasing the repeat key.

Since each of the keys on the electronic keyboard is mechanically independent, there is no interlock between them. It is therefore important to strike only one key at a time. Release each key before depressing the next one.

#### 4. CIRCUIT DESCRIPTION

The basic function of the RKB-1 circuitry is to translate keystrokes into the sequence of mark and space pulses required to transmit Baudot-coded teleprinter characters. The system is composed of six main circuits: a master clock oscillator and frequency dividers, a shift register with encoding matrix, a case control circuit, a case character decoder, an isolated loop keying switch, and a regulated power supply. A block diagram of the system is presented in Figure 4.1.

Before examining each of these sections in detail, we shall review briefly the characteristics of teleprinter character codes and trace the cycle of operations necessary to transmit one character.

The code for each character is composed of five "select" pulses or "bits". Each bit may be either a mark or a space. During a mark bit, current flows in the teleprinter loop circuit; during a space it does not. All bits are of equal duration except the stop pulse, which is normally a minimum of 50 percent longer than the others. The RKB-1 transmits a double length stop pulse at all speeds. The duration of the pulses depends on the operating speed, as shown in Table 1.

TABLE 1: RKB-1 Baudot Code Timing Data

<u>Speed (WPM)</u>	<u>Select Pulse Duration</u>	<u>Minimum Stop Pulse Duration</u>	<u>Baud Rate</u>
60	22 msec	31 msec	45.45
66	20 msec	28.2 msec	50.0
75	17.57 msec	25 msec	56.88
100	13.47 msec	19.18 msec	74.2

The start pulse is always a space, while the stop pulse is always a mark. The five intervening pulses may be any combination of marks and spaces, depending on the character to be transmitted. Each character in the Baudot code is assigned a unique sequence of marks and spaces, as shown in Table 2. The keyboard must generate the start and stop pulses plus the correct pattern of select pulses to define the character.

#### Basic Operation

The duration of the select pulses must be precisely controlled to maintain synchronism with the receiving teleprinter. Timing for the RKB-1 keyboard is provided by the master oscillator and a divider chain which reduces the oscillator output frequency by a factor of 512. The oscillator runs continuously, but the divider circuit is inhibited until a key is struck. The dividers are then released and timing pulses are allowed to flow to the logic circuits. At the same time, the correct character code from the keyboard toroid matrix is loaded into a five-bit shift register.



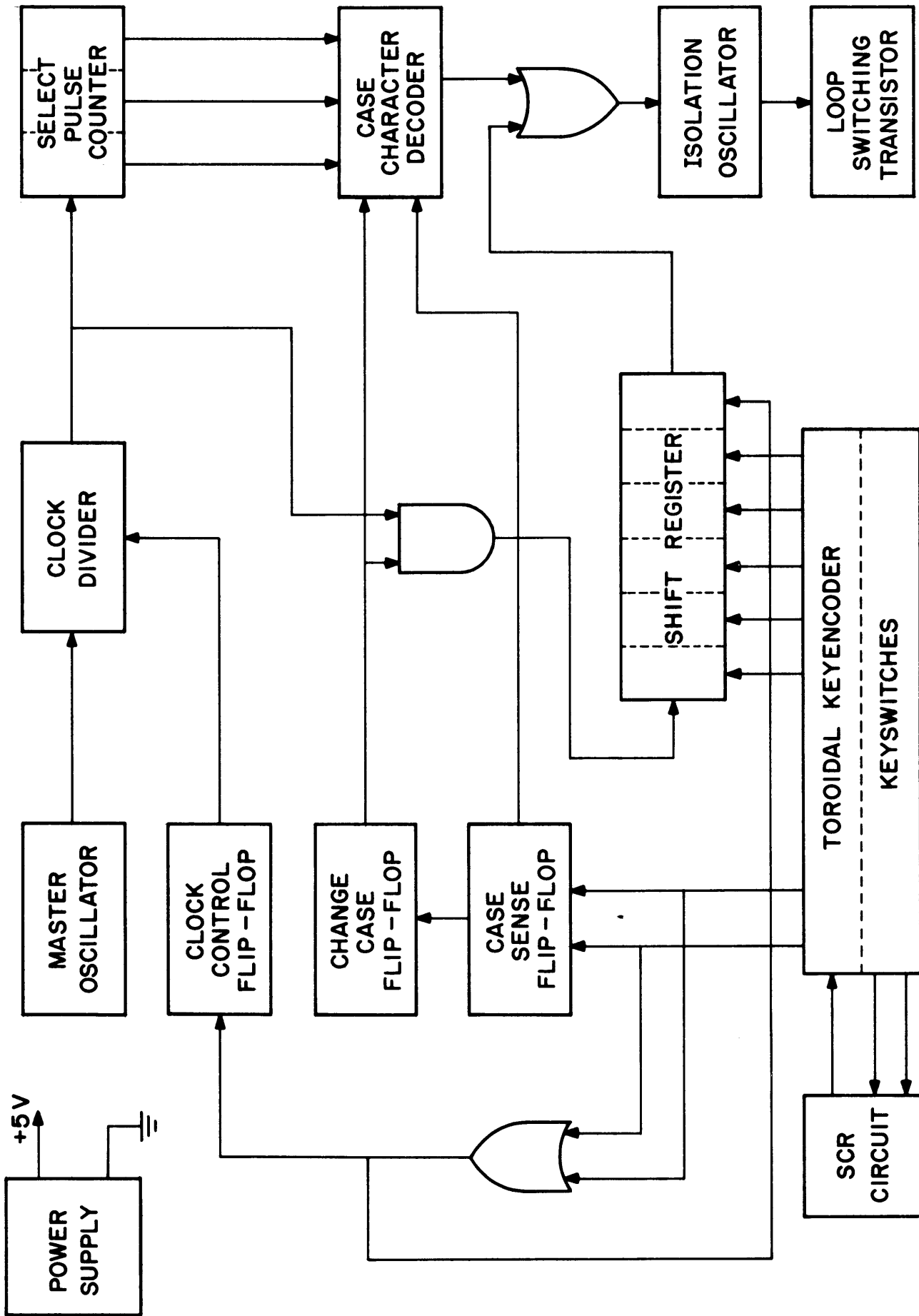

Figure 4.1 RKB-1 TTY Keyboard Block Diagram

TABLE 2: Baudot Code

<u>Letters Case</u>	<u>Figures Case</u>	<u>Start Pulse</u>	<u>Character Select Pulses</u>	<u>Stop Pulse</u>
A	-	S	M M S S S	M
B	?	S	M S S M M	M
C	:	S	S M M M S	M
D	\$	S	M S S M S	M
E	3	S	M S S S S	M
F	!	S	M S M M S	M
G	&	S	S M S M M	M
H	#	S	S S M S M	M
I	8	S	S M M S S	M
J	'	S	M M S M S	M
K	(	S	M M M M S	M
L	)	S	S M S S M	M
M	.	S	S S M M M	M
N	,	S	S S M M S	M
O	9	S	S S S M M	M
P	∅	S	S M M S M	M
Q	1	S	M M M S M	M
R	4	S	S M S M S	M
S	BELL	S	M S M S S	M
T	5	S	S S S S M	M
U	7	S	M M M S S	M
V	;	S	S M M M M	M
W	2	S	M M S S M	M
X	/	S	M S M M M	M
Y	6	S	M S M S M	M
Z	"	S	M S S S M	M
Letters		S	M M M M M	M
Figures		S	M M S M M	M
Space		S	S S M S S	M
Carriage Return		S	S S S M S	M
Line Feed		S	S M S S S	M
Blank		S	S S S S S	M

M = Mark  
S = Space

Note: Because the RKB-1 includes an automatic case shift feature, many of the figures-case characters will not be found on the same keys with the letters indicated in this table. The transmitted code, however, will be as shown.

Assuming that no change of case is called for, timing pulses flow to the shift register, and the character code stored there is clocked out. The mark and space pulses appear as high and low logic levels at the register output. These pulses key an isolation coupling oscillator, the output of which is transformer coupled to a rectifier which drives the base of the loop switching transformer. The transistor, connected in series with the external teleprinter loop circuit, conducts during mark pulses and is cut off during space pulses. Because of the transformer coupling, the transistor switch is completely isolated from the keyboard power supply and from ground.

Some keys can be used to produce a figures-case character as well as the normal letters-case character. Such keys have two separate connections to the toroid encoding matrix. If the shift key is not pressed when the character key is struck, one of these two connections is used. If the shift key is held down, the matrix is switched to the other connection. Thus, two different codes can be loaded into the shift register using the same key; a diode is used to isolate the two switch functions.

One of the most convenient features of the RKB-1 keyboard is that numbers may be sent without using the shift key. The keyboard automatically transmits the figures-shift code before it transmits the number, setting the receiving teleprinter to figures case. The next time a letter is sent, the keyboard again delays transmission of the character and sends the letters-shift code first. Also, it is not necessary to strike a figures-shift key in advance before transmitting other shifted characters. The shift key is simply depressed along with the character key, as on an ordinary typewriter. The keyboard automatically transmits the figures-shift code prior to the character code. The next time a letters-case character is sent, the letters-shift command is automatically produced.

Three circuit blocks are involved in the automatic case-shift function: the case-sense flip-flop, the change-case flip-flop, and the case character decoder. Whenever a character code is loaded into the shift register, the case-sense flip-flop is set or reset, depending upon whether the character is in letters or figures case. Of course, the case-sense flip-flop may already be set to the correct state (if the preceding character was in the same case as the current one). In that event, no case shift character is generated.

If, on the other hand, a character is struck which does cause the case-sense flip-flop to change state, the change-case flip-flop is set. An inhibit signal is then applied to stop the flow of clock pulses to the shift register, temporarily preventing it from transmitting the character. Instead, the case character decoder is activated to produce the required case-shift code. Once the case code is completed, clock pulses flow to the shift register and the keyed character is generated.

As an example, suppose that the characters "W9" are to be sent. Assume that the keyboard is in the letters mode--that is, the case-sense flip-flop is set to the letters state. When the "W" key is pressed, the required pattern of mark and space bits is loaded into the shift register through the toroid matrix. A pulse is applied to set the case-sense flip-flop to

the letters state. Since it is already in that state, however, no change occurs and the change-case flip-flop remains in the cleared state. Thus, the case character decoder remains inactive. The clock divider is enabled and clock pulses flow to the shift register.

With clock pulses applied to its input, the shift register transfers the mark and space bits stored in it to the isolation oscillator sequentially. The oscillator output keys the loop switching transistor, which in turn keys the external loop circuit, reproducing the appropriate sequence of marks and spaces. Once the character has been completed, the clock dividers are again inhibited, stopping the flow of clock pulses to the shift register. The keyboard then becomes inactive until the next key is struck.

Now the "9" key is pressed. The proper pattern of mark and space bits is loaded into the shift register. A pulse is also applied to the "figures" terminal of the case-sense flip-flop, changing it to the figures state. As a result, the change-case flip-flop is set, preventing clock pulses from reaching the shift register. Instead, the case character decoder is activated. It produces the proper sequence of mark and space characters to transmit the figures-shift code, setting the receiving teleprinter to figures case.

Once the shift character is completed, the change case flip-flop is cleared, clock pulses are allowed to pass to the shift register, and the character "9" is transmitted. When the character has been completed, the clock dividers are again inhibited and the keyboard becomes inactive. If the next character is a letter, the case-sense flip-flop switches back to the letters state, the change-case flip-flop again is set, and the letters-shift code is transmitted prior to the character.

### Circuit Details

Now that a complete cycle of operation for both letters and figures case characters has been described, we shall examine in greater detail each of the circuit blocks as an aid in testing and maintaining the keyboard. For the following discussion, it will be useful to refer to the schematic diagram included with this manual (see Figure 6.1, page 22).

### Clock Oscillator and Divider Chain

Because its output frequency is reduced by a factor of 512 in the divider chain, the master oscillator period is 1/512th of the desired select pulse length. For example, at 60 words per minute (WPM), each select pulse is 22 milliseconds long. The clock period is therefore 43 microseconds, corresponding to a frequency of 23,272 Hertz. Select pulse lengths and clock frequencies for the four operating speeds are listed in Table 3.

TABLE 3: Master Oscillator Frequencies

<u>Speed (WPM)</u>	<u>Select Pulse Duration</u>	<u>Master Oscillator Frequency</u>	<u>Adjust Pot at Terminal No.</u>
60	22 msec	23,272 Hz	3
66	20 msec	25,600 Hz	4
75	17.5 msec	29,140 Hz	5
100	13.47 msec	38,010 Hz	6

The master oscillator, which determines the operating speed of the keyboard, consists of a unijunction transistor, a timing capacitor, and four resistor networks, one for each speed. The speed switch selects one of the four timing resistances, each of which is adjustable with a potentiometer. The transistor, an MU4892, normally conducts only a small amount of current through its base-biasing resistors. The mylar timing capacitor connected to the emitter charges through the timing resistance until it reaches the firing voltage of the transistor. The emitter then conducts, draining the charge from the capacitor through the 100-ohm base resistor to ground. When the capacitor is fully discharged the emitter ceases to conduct and the capacitor begins to recharge. The charging rate, and therefore the oscillator frequency, is adjusted by the potentiometers.

The current pulse which occurs when the capacitor discharges produces a voltage spike across the 100-ohm resistor. This pulse is applied to the base of an MPS3394 transistor. The amplified pulse at the collector drives the clock terminal of the first flip-flop in the divider chain.

The frequency divider is made up of nine flip-flops, four each in IC's 10 and 11 and one in IC-9. Provided that the reset lines (pins 2 and 3 of IC's 10 and 11) are held at the logic "false" or low level (less than 0.6 volts), each flip-flop will change state when its clock input goes from the logic "true" or high level (about 2.4 volts) to the low state. The first flip-flop changes state once for each high-to-low transition of the driver transistor output. Hence the first flip-flop divides the input frequency by a factor of two. Each succeeding stage likewise divides its input frequency by two, so that the divider chain output (pin 12 of IC-9) is 1/512th of the oscillator frequency. This signal is fed via a control gate to the shift register.

When the keyboard is inactive, the divider chain is inhibited and reset to zero by driving the reset lines high. Once a key has been struck, the reset line goes low and the flip-flops start dividing the oscillator frequency. Ideally, the first clock pulse should reach the shift register exactly one select pulse after the key is pressed. Although an oscillator pulse may not occur until 1/512th of the select pulse period after the key has been struck, the delay is small enough to be inconsequential. At 60 WPM, the maximum possible delay is about 43 microseconds. It is therefore not

necessary to key the oscillator for each character. By allowing the oscillator to run continuously at a relatively high frequency, the stability necessary to maintain synchronization of the keyboard and the receiving teleprinter is maintained.

### Toroidal Key Encoder

Each key must load a different pattern of marks and spaces into the shift register. The keys must therefore be electrically isolated from each other. This function is performed by the toroid matrix located on the keyswitch circuit board.

There are seven toroidal transformers, one for each flip-flop in the five-bit shift register and two connected to the case-sense flip-flop. The secondary windings of the first five toroids (T0 through T4) are connected to the preset terminals of the shift register flip-flops. The secondaries of the other two, T5 and T6, are connected to the set and reset terminals of the case-sense flip-flop.

The transformer primaries consist of lengths of wire connected between the 2N5062 silicon controlled rectifiers (SCR's) and the keyswitches. There is one primary wire for each character. The wire for each unshifted character originates at the anode of the "unshifted" SCR (pin 20 of the circuit board) and passes through the center holes of the toroids (T0 through T4) connected to those shift register bits which must set to the space state. The wire bypasses the toroids of those stages which are to remain in the mark condition. The wire then passes through the letters toroid (T5) or the figures toroid (T6), depending on whether the character being coded is a letters case or figures case character. If the character being coded corresponds to a single function keyswitch on the keyboard, the other end of the wire is connected to the corresponding keyswitch. If the character being coded corresponds to dual function keyswitch, the other end of the wire is connected to the corresponding diode group. The common point of each diode group is connected to the corresponding dual function keyswitch.

The wires for shifted characters are connected in the same manner, except that they originate at the "shifted" SCR (circuit card pin 12) and pass through the "figures" toroid, T5.

When a keyswitch is closed and the SCR fires, a pulse passes from the SCR to ground through the wire connected to that keyswitch, inducing a voltage pulse in the secondaries of those toroids through which it passes. The outputs of the flip-flops connected to these toroids are consequently set to the high state, representing a space bit. The pulse induced in either the letters or figures toroid sets the case-sense flip-flop to the proper case.

Some keyswitches are capable of producing both a shifted and an unshifted character. These keyswitches are tied to two primary wires. One of the wires originates at the shifted SCR and the other at the unshifted SCR. The wire that is pulsed depends on which of the SCR's is fired, which in turn depends on whether the shift keyswitch is open or closed. The two primary wires are isolated from each other by diodes.

The shift keys, which are tied in parallel, are connected through an inverter (pins 12 and 13 of IC-4) to the anode of the shifted SCR. If the shift

keyswitch is held closed, pin 13 of IC-4 is low. Pin 12 is therefore high and the shifted SCR can conduct current to the primary wires for shifted characters. If the shift keyswitch is open, this SCR is cut off and a positive voltage is provided to the anode of the unshifted SCR. It therefore can conduct current to the unshifted character primaries. The actual character sent, of course, whether in letters case or figures case, is determined by which character keyswitch is closed.

### Clock Control Flip-Flop

The pulse applied through toroid T5 or T6 to the case-sense flip-flop is also coupled through a NAND gate to the clock control flip-flop. If the keyboard is inactive (prior to the closure of the keyswitch), the pulse sets the latter flip-flop to the active state, driving the output at pin 4 of IC-8 low. As a result, the inhibiting signal is removed from the clock dividers and timing pulses are allowed to flow to the logic circuitry. At the same time, the opposite output of the clock-control flip-flop (pin 13 of IC-8) goes high. This signal, coupled through an inverter (pins 5 and 6 of IC-4) to the gate terminal of the SCR's, prevents the SCR's from firing again until the character has been transmitted and the clock control flip-flop has been reset. The keyswitches are therefore disabled and the contents of the shift register cannot be altered by additional keystrokes during the transmission of a character.

A special circuit feature is included to prevent the unintentional repetition of characters. Once a character key has been struck, the SCR's are prevented from firing again until the clock control flip-flop has been reset and the character key has been released. The base of an MPS3394 transistor is diode coupled to both the shifted and unshifted SCR cathodes. When a keyswitch is closed, one or the other of these lines will go low, cutting off the transistor. The collector of the transistor rises to +5 volts, driving the input of an inverter (pin 11 of IC-4) high. The inverter output pulls the SCR gate terminals low, preventing the high circuit from retriggering until the keyswitch is released.

A repeat key is provided to override this lockout feature when a character is to be sent repetitively. With the repeat keyswitch held down, the inverter input is held low and its output is free to go high. During transmission of a character, the SCR gates are held low by the clock control flip-flop. As soon as the flip-flop resets, however, the gates go high and one of the SCR's will refire. The character will be transmitted continuously until the repeat key or the character key is released.

### Shift Register

The five-bit shift register, IC-2, performs a parallel-to-serial data conversion; that is, the pattern of mark and space bits for a character are loaded into the shift register in parallel from the toroid matrix, but they appear at the output sequentially. Each time a clock pulse arrives at the toggle terminals of the shift register flip-flops, the state of each flip-flop in the chain is transferred to the next flip-flop to the right. A sixth flip-flop, part of IC-3, is inserted at the output of the five-bit register. It is used to produce the start pulse.

For the sake of simplicity, assume that a letters-case character is to be sent and that the preceding character transmitted was also in letters case. Consequently, no case shift will occur. As soon as the keyswitch is closed, the code for the letter will be loaded into the shift register. The clock-control flip-flop will be set by a pulse from the letters or figures toroid, and the same pulse, coupled through an inverter (pins 3 and 4 of IC-4) will be applied to the preset terminal of the first shift register flip-flop (pin 4 of IC-3). This first flip-flop will therefore be set to the space state to produce the start pulse. The flip-flop output (pin 5 of IC-3) will be high.

After 512 master oscillator pulses, corresponding to the duration of one select pulse, a positive-going signal will appear at the output of the divider chain (pin 12 of IC-9). The signal, coupled through a NAND gate (pins 4, 5, and 6 of IC-7) is applied to the shift terminals of the shift register flip-flops. The contents of each register flip-flop shift one stage to the right, and the first of the five character-select pulses appears at the register output. This process is repeated until all five character bits have been shifted to the register output.

At the same time that the clock pulses are supplied to the shift register, they are also fed to three counter flip-flops (the last three in IC-9), which count the total number of select pulses that have been transmitted. After eight clock pulses, the output of the counter (pin 11 of IC-9) goes low. The output pulse is coupled to pin 9 of IC-8, causing the clock control flip-flop to reset. The divider chain is then inhibited from passing further clock pulses.

The input to the last register flip-flop (pin 9 of IC-2) is grounded. Consequently, each time the register shifts, a mark bit is loaded into this flip-flop. These mark bits shift one stage to the right at each clock divider pulse, so that after six pulses all of the register flip-flops are set to the mark state. Although all character bits have been shifted out of the register, two more clock pulses arrive. Therefore, two mark pulses are transmitted after the character bits. These mark pulses together serve as the stop pulse, which must be longer than the other six select pulses.

### Case Control Circuits

The toroid primary wire for each character passes through either the letters or the figures toroid, as noted before. The pulses induced when a keyswitch is closed set the case-sense flip-flop to either the figures or the letters state, depending on whether the character keyed is letters or figures case, respectively. Thus, the flip-flop remembers which case was used for the character most recently sent. In the figures state, the output from pin 11 of IC-7 is high; in letters state, the output is low.

Both outputs are coupled to the toggle terminal of the change-case flip-flop through a NOR gate. The latter flip-flop is reset at the end of each character by a pulse from the select pulse counter (pin 11 of IC-9). As long as the case-sense flip-flop does not change states, the change-case



flip-flop remains in the reset state. However, if a letters case character is followed by a figures case character or vice versa, the change-case flip-flop will toggle to the set state at the beginning of the second character, indicating that a change of case has occurred.

When the change-case flip-flop is set, the input at pin 8 (IC-3) goes low, driving low one input of the NAND gate that controls the flow of timing pulses to the shift register (pin 5 of IC-7). Thus, the new character, although its code is loaded into the shift register, is not transmitted immediately. Instead, the high output at pin 9 of IC-3 (coupled to pins 9 and 3 of IC-5), activates the case character decoder. The decoder then generates the proper case shift code before the new character is clocked out of the shift register.

A series of logic gates comprise the case character decoder. The case shift codes, like all other teleprinter characters, consist of five character-select pulses preceded by a start pulse and followed by a stop pulse, as indicated in Table 2. To produce the character, the gates "decode" the outputs of the select pulse counter flip-flops.

An input to pin 5 of IC-1 and pin 9 of IC-5 from the case-sense flip-flop determines whether the case character decoder produces the letters-shift or the figures-shift code. If the input to pin 5 of IC-1, driven by pin 11 of IC-7, is high, the figures-shift code is generated. If the line is low, the decoder produces the letters-shift code.

Figure 4.2 shows the waveforms at key points in the case character decoder. The clock waveform (1) is supplied to the three select-pulse counter stages, as usual. The outputs of these flip-flops (waveforms 2, 3, and 4) drive an inverter and three NAND gates. The signals from these circuits (waveforms 5, 6, 7, and 8) in turn drive two additional NAND gates. The outputs of the latter gates (waveforms 9 and 10) are fed to two control gates. The control gates also receive inputs from the change-case flip-flop and the case-sense flip-flop.

The signal from the change-case flip-flop enables the gates when shift characters are to be produced. Note that the decoder operates whenever the clock divider is active, but its output waveform is allowed to reach the loop keying switch only when the change-case flip-flop has been set. The other input to the control gate, supplied by the case-sense flip-flop determines whether waveform 9, the letters-shift code, or waveform 10, the figures-shift code, is passed to the keying switch.

Once all eight clock pulses for the case-shift character have entered the select-pulse counter, a reset pulse is produced at the counter output (pin 11 of IC-9). This pulse would normally reset both the change-case flip-flop and the clock control flip-flop, stopping the flow of clock pulses. However, when the change-case flip-flop is in the set condition, as it is at the end of a case shift character, the low output at pin 8 (IC-3) holds pin 8 of IC-8 high, preventing the clock control flip-flop from resetting. Hence, only the change-case flip-flop is reset and clock pulses continue to flow. The control gate at the toggle input of the shift register is now opened by the high level at pin 8 of IC-3, allowing clock

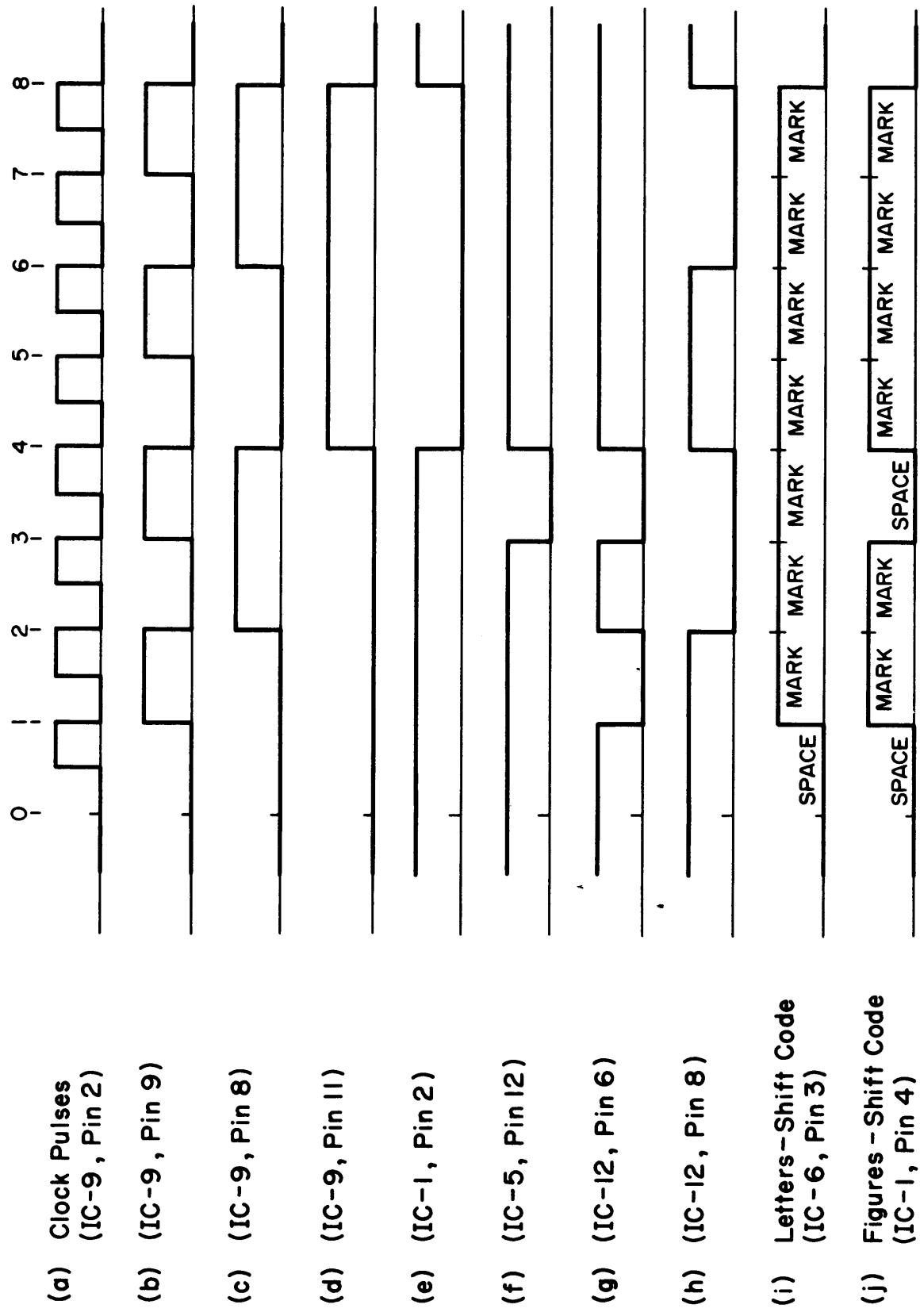

Figure 4.2 Case Character Decoder Waveforms

pulses to flow to the register. The character which was stored in the register at the beginning of the case change sequence is subsequently transmitted in the normal manner.

### Isolated Loop Switch

Mark and space pulses from either the shift register or the case character decoder, whichever is active at a particular time, pass through a NAND gate to the input of a control gate (pin 4 of IC-6) in the isolation coupling oscillator. The oscillator is activated when the input is high.

The output of the oscillator (pin 8 of IC-1) is amplified by a 2N697 transistor and is transformer coupled to a rectifier circuit. The input waveform at the oscillator control gate is therefore reproduced at the base of the 2N5655 loop switching transistor. When the oscillator is running, the transistor conducts, producing a mark pulse. When the oscillator stops (with the input to pin 4 of IC-6 held low), the loop switching transistor is cut off, resulting in a space pulse.

The loop switching transistor is protected from inductive switching transients which may occur in the external loop circuit by a diode connected in reverse polarity from the collector to the emitter. A single-pole switch, ganged with the keyboard power switch, is connected in parallel with the diode so that when the keyboard power is switched off the loop circuit is completed.

### Regulated Power Supply

The +5 volts DC required by the RKB-1 logic circuitry is supplied by a transformer-operated full-wave rectifier and filter circuit followed by a conventional series-pass regulator circuit. A potentiometer adjusts the output voltage over a limited range.

## 5. MAINTENANCE

The RKB-1 keyboard has been carefully designed and constructed to provide years of troublefree operation. In normal service, no routine maintenance is required. Should you encounter difficulties with your keyboard, however, the information in this section will help you localize the problem. Instructions for adjusting the master oscillator are also included.

### Test Instruments

A few simple tests with a voltmeter can often help locate malfunctioning circuits or components. Thorough testing, however, is most readily accomplished with an oscilloscope having a vertical amplifier bandwidth from DC to at least 10 MHz. An accurate digital counter or a frequency standard is required for adjusting the operating speeds.

CAUTION: Although all logic circuits in the RKB-1 operate at low voltage, 115 volts AC is exposed at the AC power switch. When making measurements, use insulated test probes and be careful not to contact the AC wiring.

### Adjusting Operating Speeds

The keyboard operating speed is determined by the frequency of the master oscillator. Any of four speeds may be chosen by the front-panel speed switch, which connects the oscillator timing capacitor to one of four trimming potentiometers (refer to the schematic diagram).

The oscillator frequency will vary somewhat with the power supply output voltage. The supply is well regulated so that changes in line voltage will not affect the operating speeds. Before adjusting the oscillator frequency; however, measure the output of the power supply and adjust it, if necessary, to +5.0 volts (within  $\pm 0.1$  volt). Do not vary the supply voltage setting after the oscillator has been adjusted.

To measure the oscillator frequency, connect a counter or frequency meter to pin 11 of IC-11. Be careful not to allow the connection to short to adjacent pins of the integrated circuit.

Set the speed switch to 60 WPM and turn the keyboard power switch on. Measure and record the oscillator frequency. It should be within  $\pm 100$  Hz of 23,272 Hz, as indicated in Table 3. If it is not, adjust the pot connected to circuit board terminal 3 (see schematic) until the correct frequency is obtained.

Set the speed switch to 66 WPM and adjust the oscillator frequency, if necessary, with the pot connected to terminal 4. Adjust the other two speeds in the same manner, referring to Table 3 (page 10) for the correct frequencies and pot connections.

## Troubleshooting

Although the logic circuits of the RKB-1 are relatively complex, it will normally be possible to isolate any malfunction to a specific stage or device by using a good oscilloscope and signal tracing techniques. Before attempting to service the keyboard circuitry, double check all external connections to the loop keying jack. Be especially careful to check the loop polarity, as explained in Section 1 of this manual.

The following list of symptoms, possible causes, and diagnostic measurements is provided to aid in isolating faults. Familiarity with basic digital logic devices will be an asset when servicing the keyboard. It will also be helpful to review Section 4 of this manual for a full description of the keyboard circuits and their functions.

1. Symptom: No output; keyboard remains in mark state after keystroke.

### Possible Causes:

- A. Loop connections incorrect or of wrong polarity. Recheck wiring and test polarity with a DC voltmeter.
  - B. Keying transistor or protection diode shorted. Connect scope to pin 8 of IC-1. 1 MHz isolation oscillator signal should be present. Now, press "R" key. Signal should be interrupted periodically, producing bursts. This signal should also appear at the collector of the 2N697 which drives the isolation toroid. If so, proper drive is being supplied to the rectifier circuit. Check the toroid, rectifier, keying transistor, and protection diode. Note that the keying transistor and its associated components are isolated from ground. Therefore, grounded test instrument leads should not be connected to this portion of the circuit unless the loop power supply is first switched off.
  - C. SCR not firing. Make sure shift key is not depressed, then check the voltage at pin 8 of IC-4. The output level should be high. Connect the scope to circuit board terminal 20 (the anode of the unshifted SCR). Strike any key (without pressing the shift key); a positive pulse should appear.
  - D. Power switch defective. A SPST switch ganged to the keyboard AC power switch shorts across the keying transistor when the keyboard is switched on. If this switch contact fails to open when the power is switched on, the keyboard will be held in the mark state.
  - E. A keyswitch may be stuck down. Push repeat key to determine which one.
2. Symptom: No output; keyboard remains in the space state.

### Possible Causes:

- A. Keyboard power supply inoperative. Check fuse. Measure supply output at the emitter of the MJE521 pass transistor. It should be within one-tenth of a volt of +5 volts. If not, check for

defective supply components and for shorts on the supply output. Note that readjusting the power supply voltage necessitates resetting the master oscillator frequencies.

- B. Master oscillator not running. Check the waveform at pin 11 of IC-11. Clock pulses will be present if the master oscillator is working properly.
  - C. Clock divider not functioning. Connect the scope to pin 12 of IC-9. Strike any letter key. Eight pulses should be produced. If not, connect the scope to pin 2 or 3 of IC-11. This point should be high (about +3 to +5 volts) before the key is struck, and should go low after the keystroke. If the point goes low and the clock dividers still do not produce output pulses, the master oscillator is not running or the divider chain is defective. If the terminal does not go low, the clock-control flip-flop is not being set.
  - D. Isolation coupling oscillator inoperative. Connect the scope to pin 8 of IC-1. The oscillator signal (approximately 1 MHz) should be present continuously if no keys are pressed.
3. Symptom: Keyboard transmits at incorrect speed; prints gibberish.
- Possible Causes:
- A. Speed control set at wrong operating speed for printer being used.
  - B. Master oscillator out of adjustment. Readjust according to instructions at beginning of this section.
4. Symptom: Keyboard fails to generate case shift code prior to transmitting numbers or shifted characters.
- Possible Causes:
- A. Case-sense flip-flop inoperative. Connect scope or meter to pin 11 of IC-7. Type any letters-case character. Pin 11 should be low as soon as the key is struck (it may be low before the keystroke, too, depending on the preceding character transmitted). Next press any number key. Pin 11 should go high. If not, IC-7 may be defective. Also, check the figures toroid for a broken core or open secondary. Use a scope to check for the presence of a trigger pulse at the toroid secondary when a number key is struck.
  - B. Change-case flip-flop inoperative. Repeat the test described above, typing a letter followed by a number. When the number key is struck, both the case-sense flip-flop and the change-case flip-flop should change states. Pin 8 of IC-3 should go low for about a tenth of a second. If it doesn't, check IC-3 and the circuit which couples the output of the case-sense flip-flop to the toggle input (pin 11) of IC-3.

- C. Case character decoder inoperative. Figure 4.2 shows the proper waveforms at various points in the decoder circuit. Repeat the letter-key, number-key test outlined above, observing the circuit waveforms to determine whether they correspond to those shown in the diagram.
5. Symptom: Keyboard transmits incorrect codes for some or all letters.
- Possible Causes:
- A. Operating speeds misadjusted. Test as outlined under symptom 3.
  - B. Shift register defective. Test or replace IC-2.
  - C. One or more encoder toroids defective. Check each toroid for a broken core or open secondary winding.
6. Symptom: Keyboard fails to transmit one or more characters.
- Possible Causes:
- A. Operator typing too fast for operating speed chosen.
  - B. One or more defective keyswitches. Turn keyboard AC power off and check suspected keyswitches with an ohmmeter. Keyswitch contacts are normally open, and should close when the key is pressed.

#### Factory Repair

If you wish, you may return your keyboard to HAL Communications Corporation for repair or adjustment. Before shipping the keyboard, please notify the factory by letter, describing the nature of the difficulty. A written return authorization will be mailed to you promptly. Do not send the keyboard until you have received this authorization. For the terms under which warranty service will be performed, please read the warranty at the front of this manual.

## 6. DIAGRAMS AND PHOTOGRAPHS

On the following pages are the diagrams and photographs for the RKB-1 Keyboard.



Circuit Number	Type	+5	Gnd.
1	7404	14	7
2	7496	5	12
3	7474	14	7
4	7405	14	7
5	7410	14	7
6	7400	14	7
7	7402	14	7
8	7402	14	7
9	7493	5	10
10	7493	5	10
11	7493	5	10
12	7400	14	7

Speed	Frequency
60 WPM	23,272 Hz
66	25,600
75	29,140
100	38,010
132 (optional)	51,200

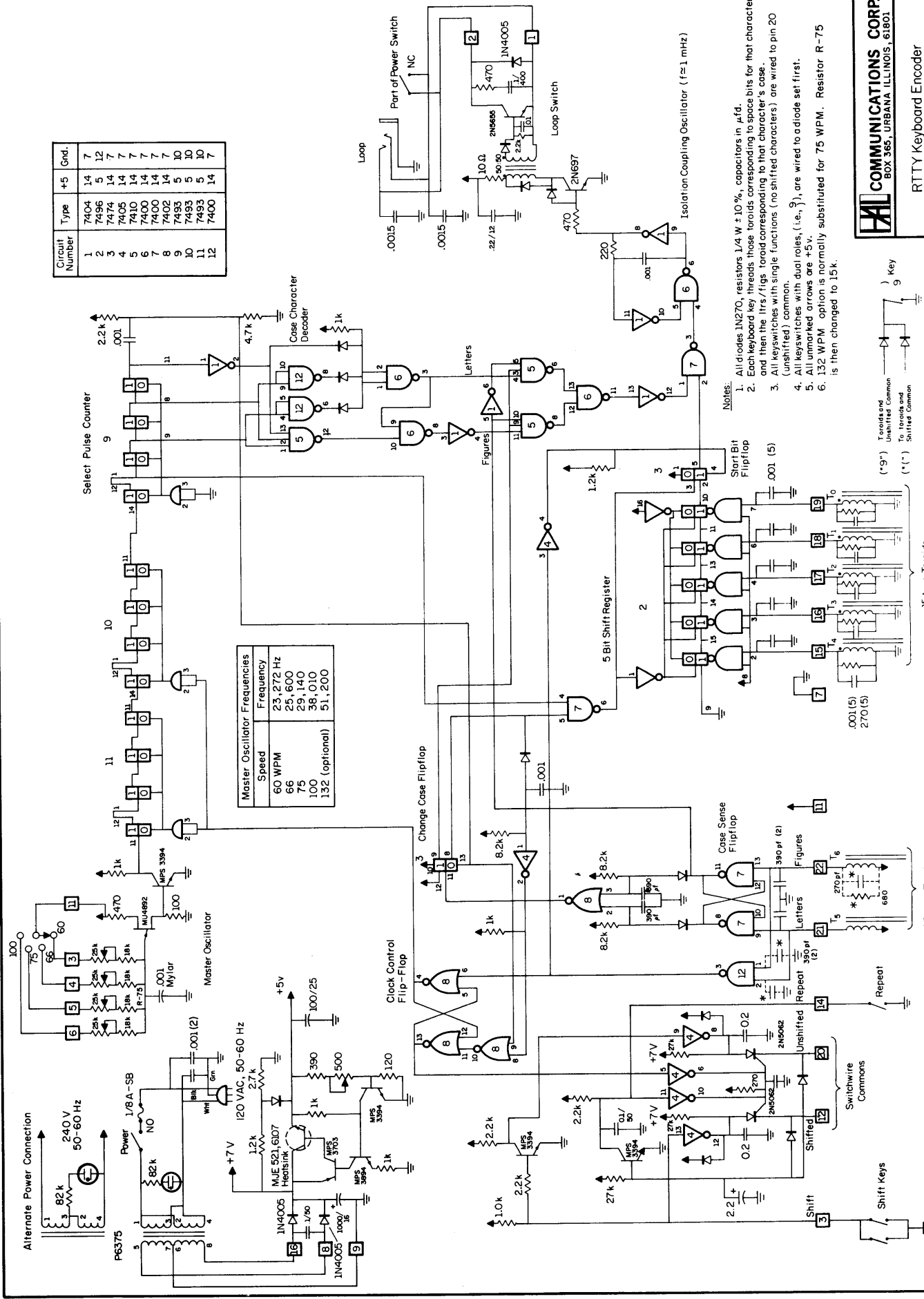

- Notes:
1. All diodes 1N270, resistors 1/4 W ± 10%, capacitors in  $\mu$ f.
  2. Each keyboard key threads those toroids corresponding to space bits for that character and then the ltrs/figs toroid corresponding to that character's case.
  3. All keyswitches with single functions (no shifted characters) are wired to pin 20 (unshifted) common.
  4. All keyswitches with dual roles (i.e.,  $\bar{9}$ ), are wired to a diode set first.
  5. All unmarked arrows are +5V.
  6. 132 WPM option is normally substituted for 75 WPM. Resistor R-75 is then changed to 15k.

**HAL COMMUNICATIONS CORP.**  
 BOX 365, URBANA, ILLINOIS, 61801

RTTY Keyboard Encoder

DATE: June 26, 1972  
 SCALE: \_\_\_\_\_  
 APPROVED: P. Tucker  
 No. RKB-1A

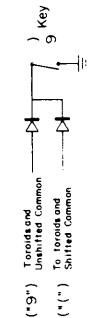

Rev. Nov. 29, 1973

\* - os required

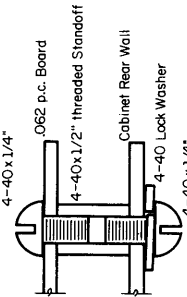

Board Mounting Detail

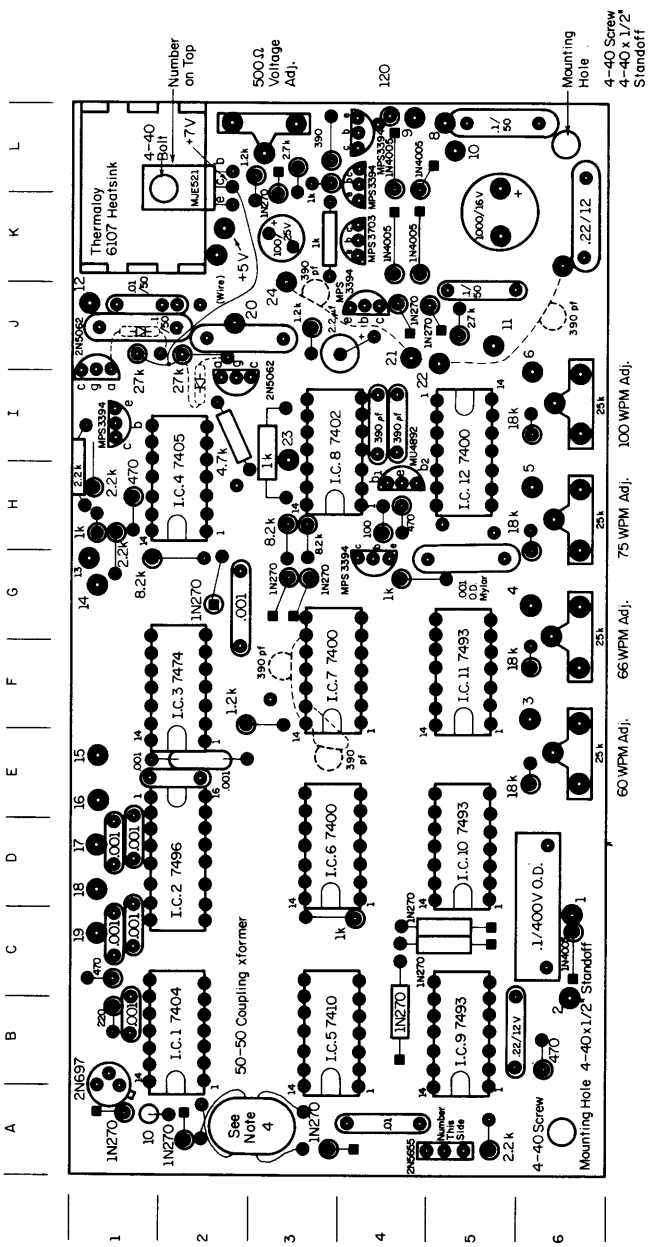

Parts List:

Resistors	Capacitors	Semiconductors	Integrated Circuits	Miscellaneous
10	390 pf	1N270	7400	50-50 Turn Pulse xformer A-3
100	.001 μf	I-4 (2), J-3, J-6	7402	D-3, F-3, H-5
120	.001 μf	B-1, C-1(2), D-1(2), E-2(2), G-2	7404	L-3
220	.001 μf O.D.	G-5	7405	H-2
390	.01 μf	A-4, J-1	7410	B-3
470	.1 μf Disk	J-1, J-2, J-5, L-5	7414	F-2
1000	.1 μf O.D.	D-6	7493	B-5, D-5, F-5
1500	.22 μf	B-5, K-6	7496	D-2
2000	1.2 μf	J-4		
2700	2.2 μf	K-4		
4700	1000 μf	I-1, I-2		
8200		A-3		
18000				
27000				
50000 Trim				
500 Trim				

Notes:

- 1) All resistances in ohms, k=1000.
- 2) All diodes have cathode toward square pad.
- 3) All capacitors in μf unless otherwise noted.
- 4) Note reversed transformer leads at one end of 50-50 pulse transformer.
- 5) 390 pf capacitors at F-3, J-3 and J-6 (4) and 1N270 diodes at J-1 and J-2 (2) are mounted on the reverse side of the board.
- 6) 390 pf capacitors at F-3(2) are as required.

Rev. : Dec. 3, 1973

**FAL COMMUNICATIONS CORP.**  
 BOX 365, URBANA, ILLINOIS, 61801

RKB-1 Assembly Drawing

DATE Sept. 7, 1972 SCALE  
 APPROVED P. Tucker No. RKB-1A-Assy 1

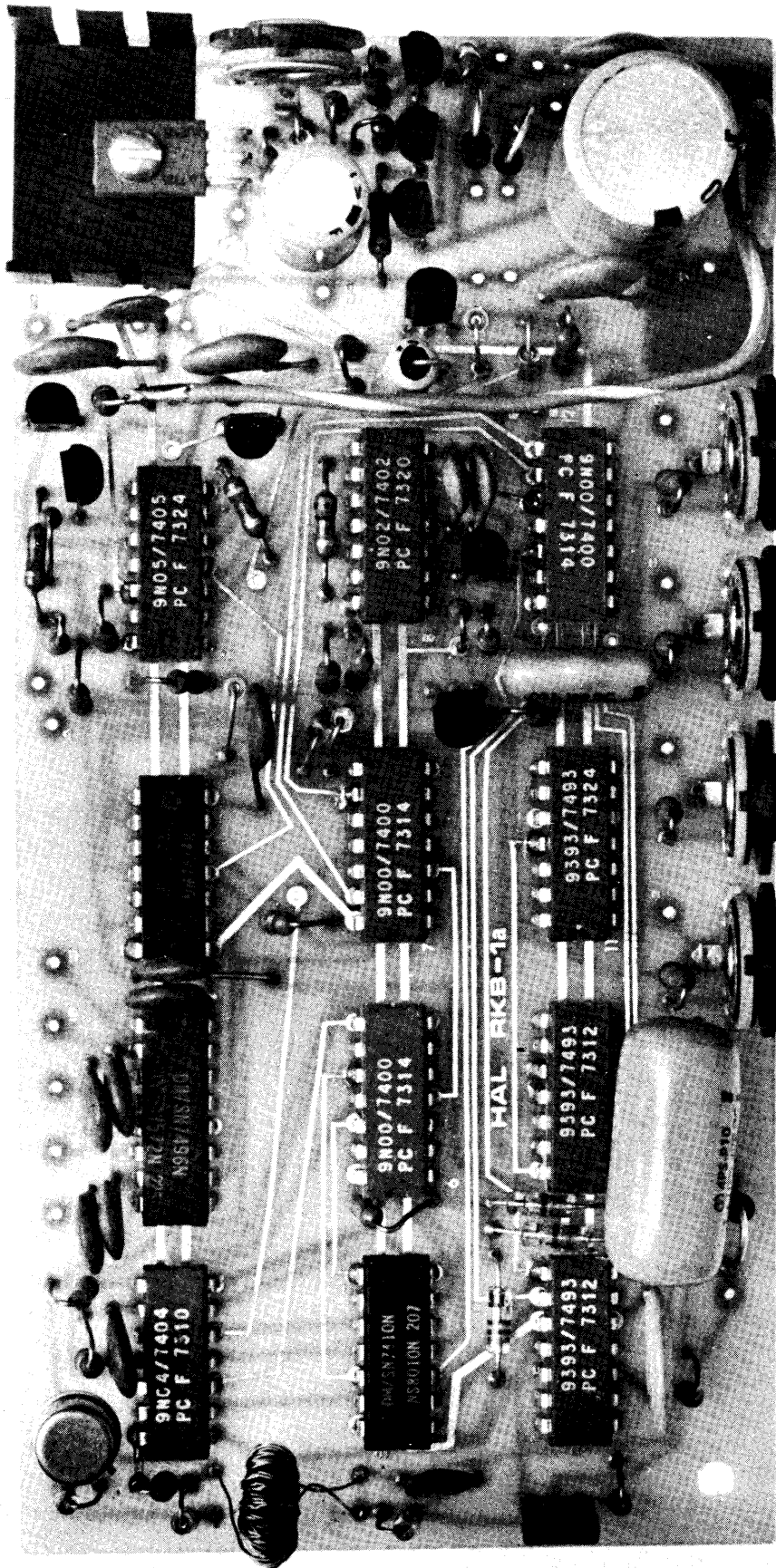

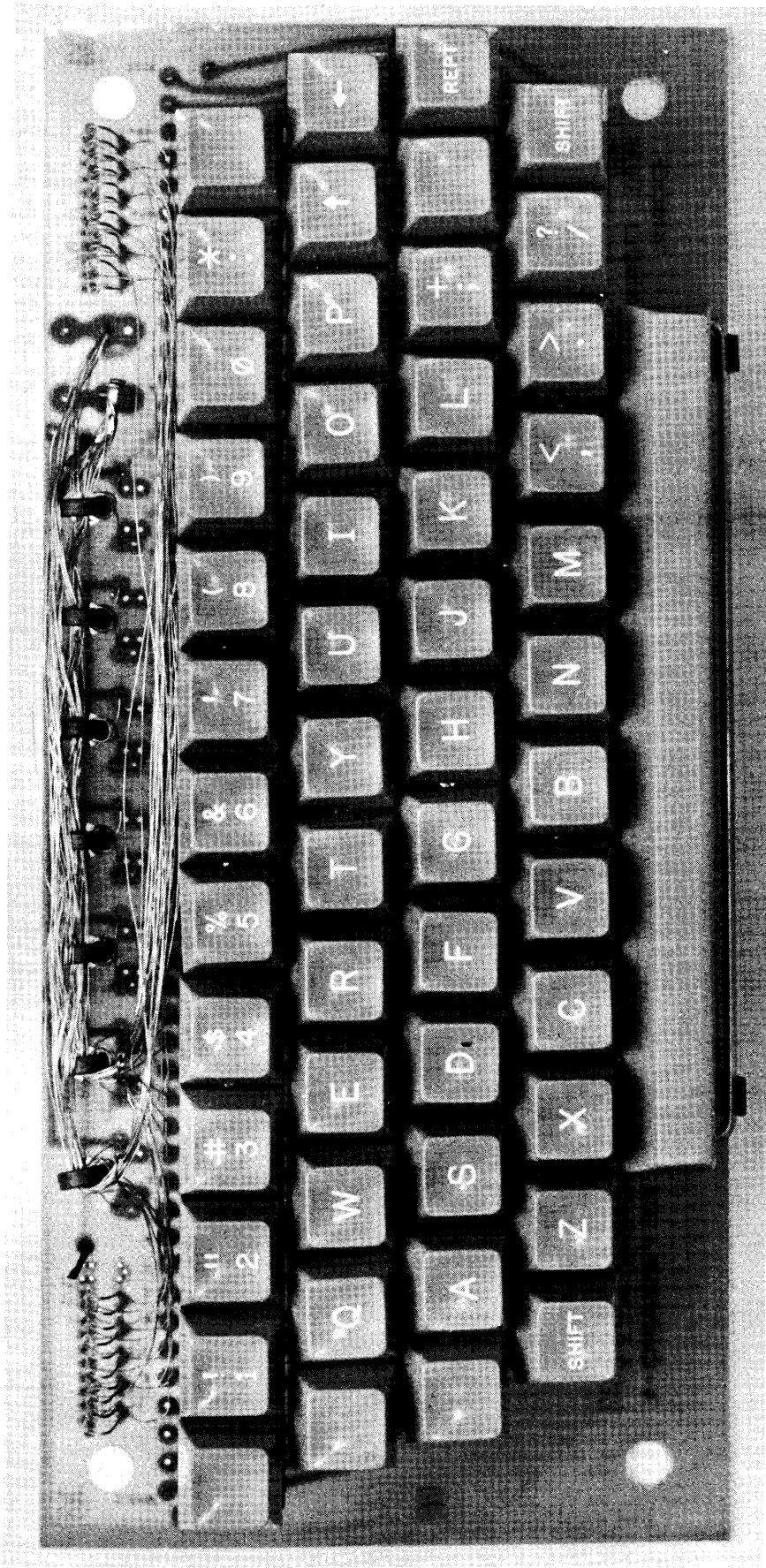

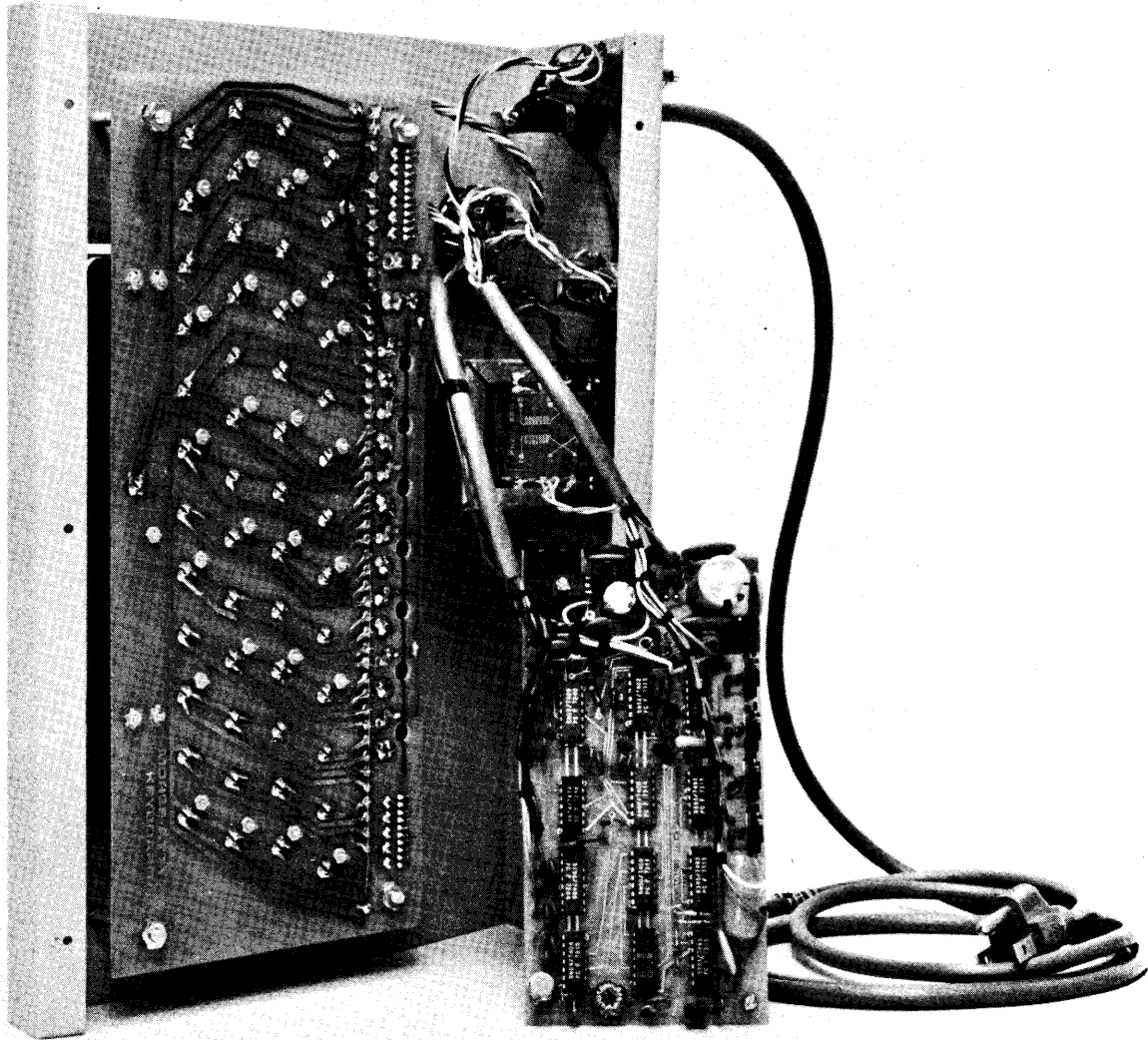

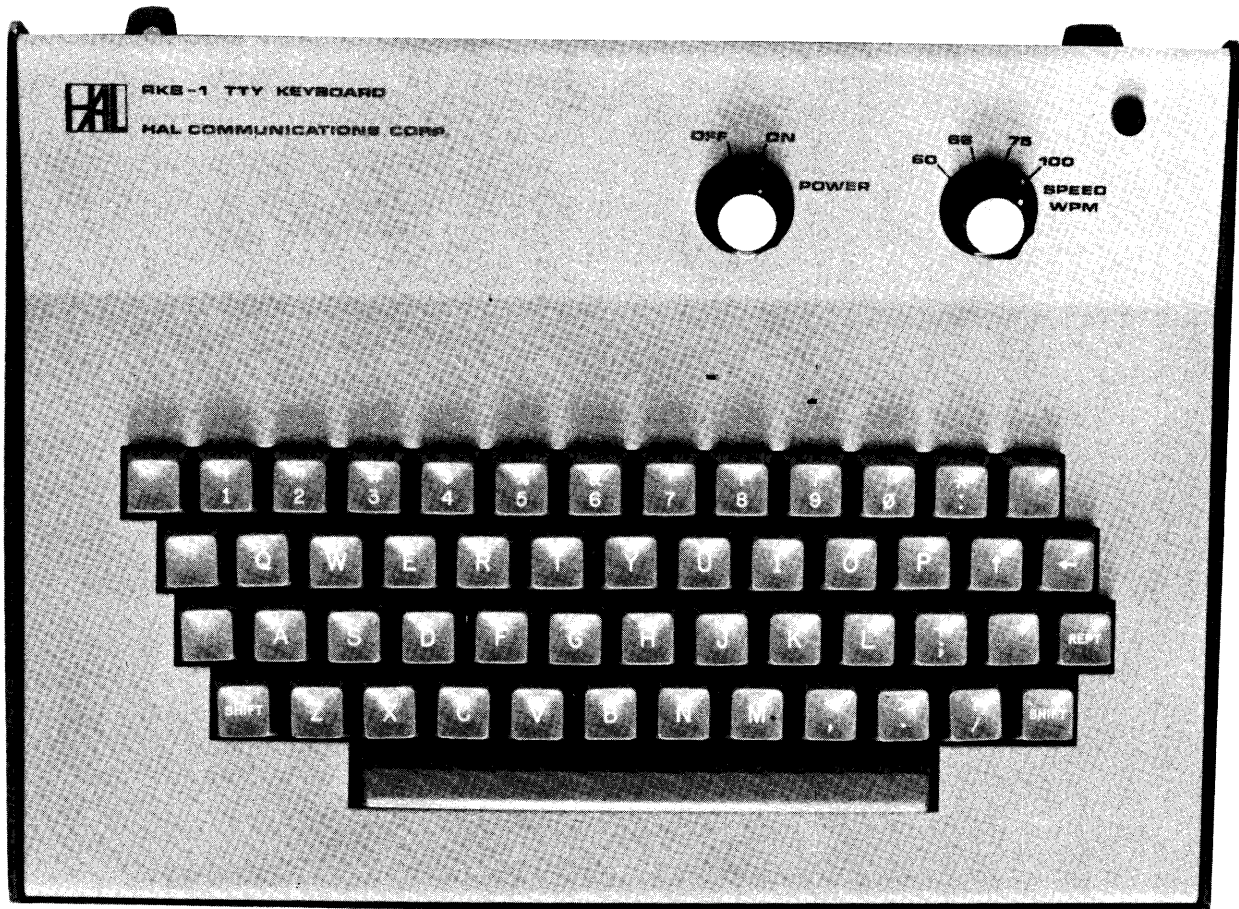

## 7. PARTS LIST

The following components comprise the complete RKB-1 keyboard. After the description of each component is a letter in parentheses indicating the location of the part, according to the following code:

L--logic board

K--keyswitch board

C--cabinet

### Resistors

1	10 ohm, $\frac{1}{2}$ watt	(L)
1	100 ohm, $\frac{1}{2}$ watt	(L)
1	120 ohm, $\frac{1}{2}$ watt	(L)
1	220 ohm, $\frac{1}{2}$ watt	(L)
5	270 ohm, $\frac{1}{2}$ watt	(K)
1	390 ohm, $\frac{1}{2}$ watt	(L)
4	470 ohm, $\frac{1}{2}$ watt	(L)
1	500 ohm trim-pot	(L)
6	1000 ohm, $\frac{1}{2}$ watt	(L)
3	1200 ohm, $\frac{1}{2}$ watt	(L)
6	2200 ohm, $\frac{1}{2}$ watt	(4L, 2K)
2	2700 ohm, $\frac{1}{2}$ watt	(L)
1	4700 ohm, $\frac{1}{2}$ watt	(L)
3	8200 ohm, $\frac{1}{2}$ watt	(L)
4	18K ohm, $\frac{1}{2}$ watt	(L)
4	25K ohm trim-pot	(L)
2	27K ohm, $\frac{1}{2}$ watt	(L)
1	82K ohm, $\frac{1}{2}$ watt	(C)

### Semiconductors

36	1N270 diodes	(12L, 22K)
5	1N4005 diodes	(L)
1	2N697 transistor	(L)
2	2N5062 SCR	(L)
1	2N5655 transistor	(L)
1	MJE521 transistor	(L)
1	MPS-3703 transistor	(L)
5	MPS-3394 transistor	(L)
3	7400 integrated circuits	(L)
1	7402 integrated circuit	(L)
1	7404 integrated circuit	(L)
1	7405 integrated circuit	(L)
1	7410 integrated circuit	(L)
1	7474 integrated circuit	(L)
3	7493 integrated circuit	(L)
1	7496 integrated circuit	(L)

### Capacitors

4	390 pf disc ceramic	(L)
12	.001 $\mu$ f/500 V disc ceramic	(7L, 5K)
1	.001 $\mu$ f/100 V mylar	(L)
2	.001 $\mu$ f/2 kV disc ceramic	(C)
2	.01 $\mu$ f/100 V disc ceramic	(L)
4	.1 $\mu$ f/25 V disc ceramic	(L)
1	.1 $\mu$ f/400 V mylar	(L)
2	.22 $\mu$ f/12 V disc ceramic	(L)
1	2.2 $\mu$ f/25 V electrolytic	(L)
1	100 $\mu$ f/25 V electrolytic	(L)
1	1000 $\mu$ f/25 V electrolytic	(L)

### Transformers and Cores

1	P6375 transformer, power	(C)
8	CF102-06 toroids	(1L, 7K)

### Wire and Cable

81 ft.	#30 Beldsol wire	(L,K)
30 in.	#22 hookup wire	(C)
38 in.	12-conductor cable	(C)

### Sockets and Connectors

1	2-circuit phone jack, $\frac{1}{4}$ "	(C)
1	-HKB fuseholder	(C)
1	2-circuit phone plug, $\frac{1}{4}$ "	

Switches

9 4-unit keyswitches (K)  
 3 5-unit keyswitches (K)  
 1 1-unit keyswitch (K)  
 1 DPDT rotary switch (AC Power) (C)  
 1 3P4T rotary switch (Speed) (C)

Miscellaneous Parts

1 6107B heat sink (L)  
 1 space-bar assembly (K)  
 1 set of 51 keytops (K)  
 1 logic circuit board (L)  
 1 keyswitch circuit board (K)  
  
 2 knobs (C)  
 1 neon pilot lamp assembly (C)  
 1 1/8 amp time-delay fuse (C)  
 1 6-lug terminal strip (C)  
 1 AC power cord (C)  
  
 1 power cord strain relief (C)  
 1 3/8 inch hole plug (C)  
 5 inches of insulated sleeving (C)  
 4 rubber feet (C)  
 1 RKB-1 serial number tag (C)  
  
 1 cabinet, top  
 1 cabinet, bottom  
 1 owner's manual

Fastening Hardware

4 4-40 x 1/2 machine screws (2L, 2C)  
 1 4-40 x 3/8 machine screw (L)  
 3 6-32 x 1/2 machine screws (C)  
 1 6-32 x 1/2 machine screw (C)  
 6 No. 6 x 3/8 SM screws (C)  
  
 25 2-56 hex nuts (K)  
 1 4-40 hex nut (L)  
 5 6-32 hex nuts (C)  
 8 8-32 hex nuts (C)  
  
 1 No. 4 lockwasher (L)  
 4 No. 6 lockwashers (C)  
  
 2 4-40 x 1/2 spacers (L)